

## Step 1:

### Connect the Monitor and Power Supply

1. Uncrate the machine and locate the monitor and line cord
2. Plug and screw in the line cord at the back of the power supply (see Figure 1)
3. Slide the monitor onto the arm and lock in place (see Figure 2)
4. Insert two cables into the back of the monitor:
  - Ethernet cable
  - Power cable
5. Assemble and insert an ultrasonic stack per the User Manual.
  - Pull the magnetic cover towards you to remove it. Remove the cover and install stack (see Chapter 4 of the GSX-E1 User Manual for detailed instructions)

**Note:** Cables will fit specifically into each component; they're not interchangeable

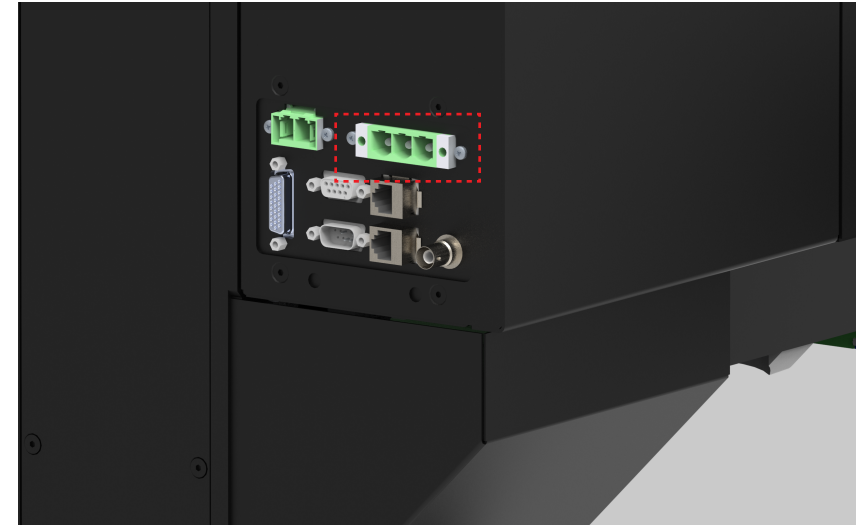

Figure 1: Line Cord Connector

1. Tilt the monitor back and lower onto the arm, so that the hook fits into the corresponding hole on the VESA bracket. Then rotate the bottom of the monitor back towards the arm until the tab snaps in place
2. To remove, lift the release tab and pull the bottom of the monitor away from the arm, then lift free of the hook

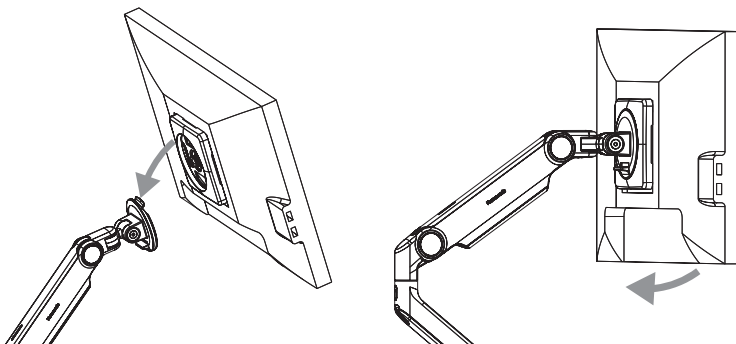
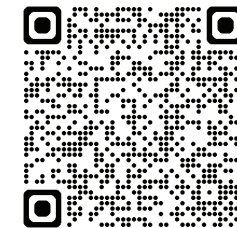

Figure 2: Monitor

## Step 2:

### Power ON the GSX-E1 System

1. Apply appropriate power to device (refer to User Manual)
2. Turn on the GSX-E1 system using the power button at the front of the power supply (see Figure 3 on reverse)
3. A login screen will appear. Enter username and password (see Chapter 5 of the GSX-E1 User Manual for detailed instructions)
4. The next screen will allow the original password to be changed



Scan for User Manual



Figure 2: Power Button

### Step 3:

#### Create a Recipe

1. Hit the menu icon at top left, then select RECIPES (see Figure 4)
2. A gray box with a + sign will appear (see Figure 5)
3. Hit the + sign
4. In the recipe dropdown menu, select SAVE (see Figure 6)

**Note:** This automatically creates a new recipe in the system using the default parameters. This step must be completed for the system to function

### Step 4:

#### Perform HORN SCAN

1. Visit the ACTION CENTER (upper right corner), and select SCAN/SEEK/TEST (see Figure 8)  
Select HORN SCAN
2. Once horn scan is complete, a graph will appear and a record of Horn Scan will be created
3. Move to the third page in the Scan/Seek/Test screen to open the Test menu  
Select and hold the START TEST button for 2-5 seconds
- 4.
- 5.

### Step 5:

#### Perform Find Part Contact

1. Place a non-metallic object under the ultrasonic horn of the machine
2. Visit the Action Center again, and select ACTUATOR SETUP
3. Select PART CONTACT
4. Hold palm buttons and the stack will come down. This will determine Part Contact.

**Note:** Max stroke length is 120 mm

5. Return to Recipe screen, select EDIT RECIPE (see Figure 7) and then SAVE
6. The machine is now running and ready to be used

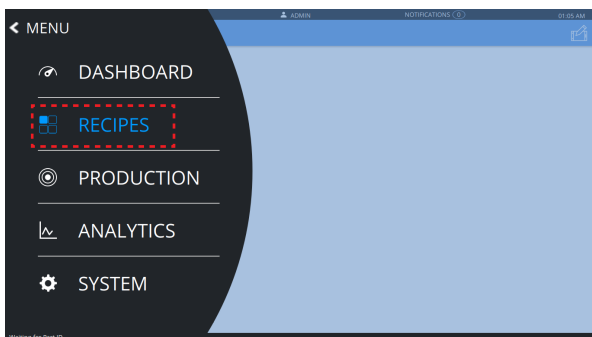

Figure 4: Menu Icon > Recipe

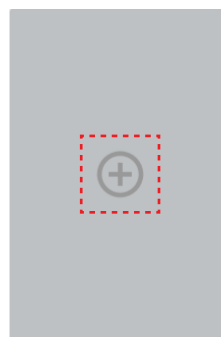

Figure 5: Gray box with + sign

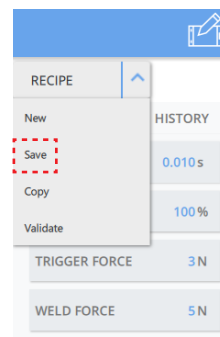

Figure 6: RECIPE dropdown > Save

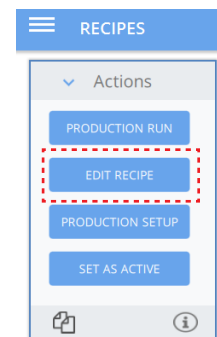

Figure 7: EDIT RECIPE

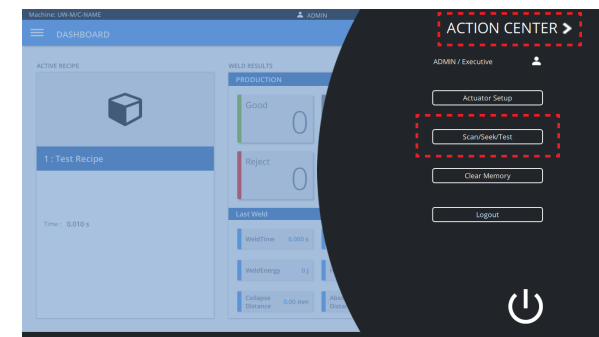

Figure 8: ACTION CENTER > SCAN/SEEK/TEST