



**EMERSON**<sup>TM</sup>

Original Instructions  
1019567 - REV. 05



## 2000IW/IW+ Integrated Welder

# Maintenance Manual

**Branson Ultrasonics Corp.**  
120 Park Ridge Road  
Brookfield, CT 06804  
(203) 796-0400  
<http://www.bransonultrasonics.com>

**BRANSON**



## **Manual Change Information**

At Branson, we strive to maintain our position as the leader in ultrasonics plastics joining, cleaning and related technologies by continually improving our circuits and components in our equipment. These improvements are incorporated as soon as they are developed and thoroughly tested.

Information concerning any improvements will be added to the appropriate technical documentation at its next revision and printing. Therefore, when requesting service assistance for specific units, note the Revision information found on this document, and refer to the printing date which appears on this page.

## **Copyright and Trademark Notice**

Copyright © 2025 Branson Ultrasonics Corporation. All rights reserved. Contents of this publication may not be reproduced in any form without the written permission of Branson Ultrasonics Corporation.

Trademarks and service marks mentioned herein are held by their respective owners.

## Foreword

Congratulations on your choice of a Branson Ultrasonics Corporation system!

The Branson 2000-Series system is process equipment for the joining of plastic parts using ultrasonic energy. It is the newest generation of product using this sophisticated technology for a variety of customer applications. This Maintenance Manual is part of the documentation set for this system, and should be kept with the equipment.

Thank you for choosing Branson!

## Introduction

This manual is arranged into several structured chapters which will help you find the information you may need to know to safely handle, install, set up, program, operate, and/or maintain this product. Please refer to the [Table Of Contents](#) and/or the [Index](#) of this manual to find the information you may be looking for. In the event you require additional assistance or information, see Section [1.4 How to Contact Branson](#) for information on how to contact the appropriate Branson representative.

---

# Table Of Contents

---

## Chapter 1: Safety and Support

1.1	Safety Requirements and Warnings . . . . .	2
1.2	General Precautions . . . . .	5
1.3	Warranty . . . . .	7
1.4	How to Contact Branson . . . . .	8
1.5	Returning Equipment for Repair . . . . .	9
1.6	Obtaining Replacement Parts . . . . .	12

## Chapter 2: The 2000IW/IW+ Welder

2.1	Models Covered . . . . .	14
2.2	Overview of these Models . . . . .	15
2.3	Compatibility with Branson Products . . . . .	18
2.4	Features . . . . .	19
2.5	Front Panel Controls . . . . .	20
2.6	Rear Panel . . . . .	27
2.7	System Inputs/Outputs . . . . .	29
2.8	Glossary . . . . .	31

## Chapter 3: Schematics

3.1	Introduction . . . . .	34
3.2	2000IW/IW+ Main Interconnect Schematic . . . . .	35
3.3	2000IW/IW+ Electrical Assemblies . . . . .	36

## Chapter 4: Troubleshooting

4.1	General Troubleshooting Procedures . . . . .	50
4.2	Troubleshooting Charts . . . . .	51
4.3	Alarms . . . . .	57

## Chapter 5: Assembly/Disassembly

5.1	Introduction . . . . .	64
5.2	Connecting and Disconnecting Air Lines . . . . .	66
5.3	Opening and Removing the Left Side Cover (EDP 100-032-338) . . . . .	67
5.4	Main Assembly . . . . .	69
5.5	Nose Assembly . . . . .	84

## Chapter 6: Repair

6.1	Periodic Maintenance Procedures . . . . .	120
-----	---	-----

## Chapter 7: Master Parts List

7.1	Parts Lists . . . . .	128
-----	-----------------------	-----



# List Of Figures

## Chapter 1: Safety and Support

Figure 1.1	Safety Labels on the Front of the 2000IW/IW+ Integrated Welder	3
Figure 1.2	Safety Label on Left Door of the 2000IW/IW+ Integrated Welder	4

## Chapter 2: The 2000IW/IW+ Welder

Figure 2.1	2000IW/IW+ Series Integrated Welder	15
Figure 2.2	Front Panel Controls, IW	20
Figure 2.3	Front Panel Displays, IW	22
Figure 2.4	Front Panel Displays, IW+	24
Figure 2.5	Rear Panel	27
Figure 2.6	Base, Showing START SWITCHES and Base Cable	29

## Chapter 3: Schematics

Figure 3.1	2000IW/IW+ Main Interconnect Schematic	35
Figure 3.2	2000IW/IW+ Line Board Location	37
Figure 3.3	IW/IW+ Control Module, Controller Board, Top and Side View	38
Figure 3.4	2000IW/IW+ Ultrasonic Power Module	40
Figure 3.5	DC Power Module	41
Figure 3.6	IW/IW+ Input Output Signals	42
Figure 3.7	Pneumatic Schematic	44
Figure 3.8	CJ 20 Converter	46

## Chapter 4: Troubleshooting

### Chapter 5: Assembly/Disassembly

Figure 5.1	Connecting and Disconnecting Air Lines	66
Figure 5.2	Opening the Left Side Cover	67
Figure 5.3	Main Assembly Components (Left Side View)	70
Figure 5.4	Main Assembly Components (Right Side View)	71
Figure 5.5	Removing the Ultrasonic Power Supply Module	72
Figure 5.6	24/5 Volt Power Supply and Box Fan	74
Figure 5.7	Circuit Breaker, On Off Switch	76
Figure 5.8	The Line Board	78
Figure 5.9	Solenoid Valve (SV)	80
Figure 5.10	Column Clamps and Elevator Knob	81
Figure 5.11	Removing a Column Clamp	82
Figure 5.12	Removing the Elevator Knob	83
Figure 5.13	Nose Assembly Components and Connections	84
Figure 5.14	Removing the Nose Assembly	86
Figure 5.15	Removing the Controller Board	88
Figure 5.16	Replacing the Keypad	91
Figure 5.17	Removing the Pressure Regulator	92
Figure 5.18	Replacing the Pressure Regulator	93
Figure 5.19	Removing the Pressure Gauge	94
Figure 5.20	Removing the Down Speed Control Valve	96
Figure 5.21	Main Support Assembly, Front View	98
Figure 5.22	Main Support Assembly, Side View	99
Figure 5.23	Removing the Converter-Booster-Horn Stack	100
Figure 5.24	Removing the Trigger Guard	102

Figure 5.25 Adjusting the Mechanical Stop . . . . .	103
Figure 5.26 Removing the Air Cylinder, Part A. . . . .	105
Figure 5.27 Removing the Air Cylinder, Part B. . . . .	106
Figure 5.28 Removing the Dynamic Trigger Mechanism . . . . .	107
Figure 5.29 Removing the RF Contact Block . . . . .	108
Figure 5.30 Removing the Carriage Return Spring . . . . .	110
Figure 5.31 Removing the Upper Limit Switch (ULS) . . . . .	111
Figure 5.32 Removing the Trigger Switch (TRS) . . . . .	113
Figure 5.33 Removing the Linear Optical Encoder (IW+ Only). . . . .	115
Figure 5.34 Shipping Spacers . . . . .	116

## **Chapter 6: Repair**

Figure 6.1 Reconditioning Stack Surfaces . . . . .	122
Figure 6.2 Disassembly of Air Filter Components . . . . .	124
Figure 6.3 Manual Adjustment Procedure Flowchart . . . . .	126

## **Chapter 7: Master Parts List**

# List Of Tables

## Chapter 1: Safety and Support

Table 1.1	Safety Label Part Number . . . . .	2
Table 1.2	Branson Contacts . . . . .	10

## Chapter 2: The 2000IW/IW+ Welder

Table 2.1	Front Panel Controls . . . . .	20
Table 2.2	Front Panel Displays, IW . . . . .	22
Table 2.3	Front Panel Displays IW+ . . . . .	24
Table 2.4	Rear Panel Connectors . . . . .	27

## Chapter 3: Schematics

Table 3.1	IW/IW+ Control Module Connector Assignments . . . . .	38
Table 3.2	Control Module Part Number . . . . .	38
Table 3.3	Pneumatic System Part Numbers . . . . .	45
Table 3.4	2000IW/IW+ Boosters . . . . .	46
Table 3.5	Other items used with the IW/IW+ . . . . .	47

## Chapter 4: Troubleshooting

Table 4.1	Fuse/Circuit Breaker Troubleshooting . . . . .	51
Table 4.2	Fan Troubleshooting . . . . .	51
Table 4.3	Ultrasonic Power Troubleshooting . . . . .	52
Table 4.4	Weld Cycle Troubleshooting . . . . .	55
Table 4.5	Alarm Types and Action . . . . .	57
Table 4.6	Error Codes . . . . .	57

## Chapter 5: Assembly/Disassembly

Table 5.1	Circuit Breaker Part Number . . . . .	77
Table 5.2	IW and IW+ Connections for P35 and JP8 . . . . .	87
Table 5.3	Air Cylinder Part Numbers . . . . .	104

## Chapter 6: Repair

Table 6.1	Stack Reconditioning Procedure . . . . .	121
Table 6.2	Stud Torque Specifications . . . . .	122
Table 6.3	Booster Interface Torque Specifications . . . . .	122
Table 6.4	Tip Interface Specifications . . . . .	122
Table 6.5	Component Replacements Based on Cycles Run . . . . .	123

## Chapter 7: Master Parts List

Table 7.1	Replacement Parts . . . . .	128
-----------	-----------------------------	-----



---

# Chapter 1: Safety and Support

---



<b>1.1</b>	<b>Safety Requirements and Warnings</b> . . . . .	<b>2</b>
<b>1.2</b>	<b>General Precautions</b> . . . . .	<b>5</b>
<b>1.3</b>	<b>Warranty</b> . . . . .	<b>7</b>
<b>1.4</b>	<b>How to Contact Branson</b> . . . . .	<b>8</b>
<b>1.5</b>	<b>Returning Equipment for Repair</b> . . . . .	<b>9</b>
<b>1.6</b>	<b>Obtaining Replacement Parts</b> . . . . .	<b>12</b>

## 1.1 Safety Requirements and Warnings

This chapter contains an explanation of the different Safety Notice symbols and icons found both in this manual and on the product itself and provides additional safety information for ultrasonic welding. This chapter also describes how to contact Branson for assistance.

### 1.1.1 Symbols Found in this Manual

These symbols used throughout this manual warrant special attention:

<b>WARNING</b>	<b>Indicates a possible danger</b>
	If these risks are not avoided, death or severe injury might result.
<b>CAUTION</b>	<b>Indicates a possible danger</b>
	If these risks are not avoided, slight or minor injury might result.
<b>NOTICE</b>	<b>Indicates a possible damaging situation</b>
	If this situation is not avoided, the system or something in its vicinity might get damaged.  Application types and other important or useful information are emphasized.

### 1.1.2 Symbols Found on the Product

Familiar graphic warning symbols are used to alert the user to items of concern or hazard. The following warning symbols appear on the 2000IW/ IW+ Integrated Welder. Replace with new labels as required.

**Table 1.1** Safety Label Part Number

Part Number	Label Description
100-065-1023	Disconnect Power, Hearing Protection Required, Do Not Touch Horn combination label
100-065-796	Crush Pinch, Emergency Stop, Warning Keep Hands Away From Moving Horn combination label

**Table 1.1** Safety Label Part Number

Part Number	Label Description
100-065-743	High Voltage. Do Not Remove Cover. Refer Service to Qualified Personnel Only. Service Personnel, Disconnect Unit From Mains. Wait 5 Minutes Before Removing Cover.

**Figure 1.1** Safety Labels on the Front of the 2000IW/IW+ Integrated Welder

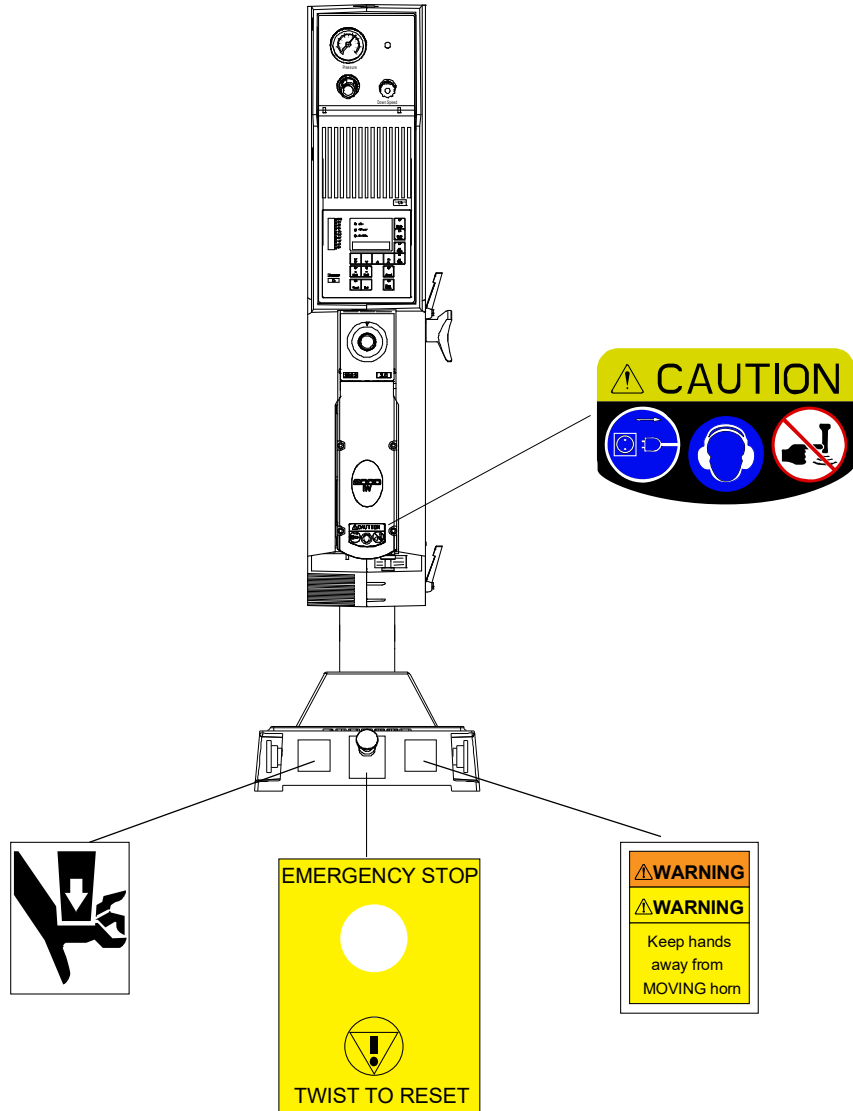

**Figure 1.2** Safety Label on Left Door of the 2000IW/IW+ Integrated Welder

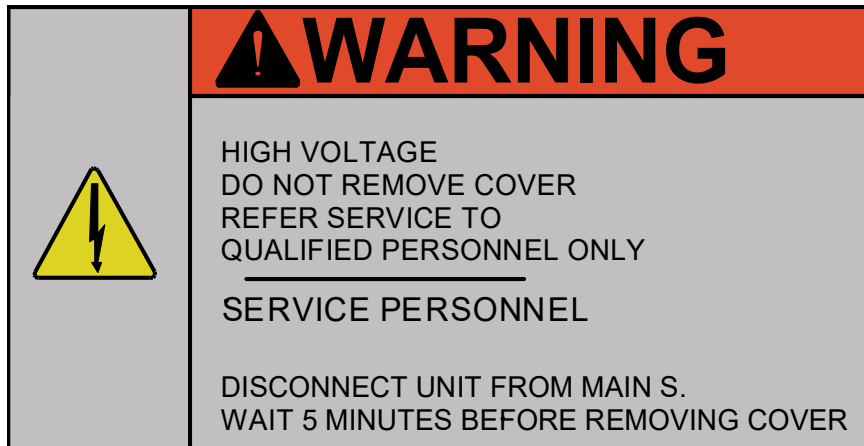

## 1.2 General Precautions

Take the following precautions before servicing the power supply, or setting DIP switches:

- Be sure the power switch is in the Off position before making any electrical connections
- To prevent the possibility of an electrical shock, always plug the power supply into a grounded power source
- Power supplies produce high voltage. Before working on the power supply module, do the following:
  - Turn off the power supply;
  - Unplug main power; and
  - Allow at least 5 minutes for capacitors to discharge.

WARNING	General Warning
	<p>If LED 1 or LED 2 on the Power Supply Module is lit, there is still High Voltage present. Wait until they are out before servicing the welder. Refer to <a href="#">Figure 3.4 2000IW/IW+ Ultrasonic Power Module</a> for location of LED 1 and 2.</p>

- High voltage is present in the power supply. Do not operate with the cover removed
- High line voltages exist in the ultrasonic power supply module. Common points are tied to circuit reference, not chassis ground. Therefore, use only non-grounded, battery-powered multimeters when testing these modules. Using other types of test equipment can present a shock hazard
- Be sure power is disconnected from the power supply before setting a DIP switch
- Keep hands from under the horn. Down force (pressure) and ultrasonic vibrations can cause injury
- Do not cycle the welding system if the converter is not installed
- When using larger horns, avoid situations where fingers could be pinched between the horn and the fixture
- Be aware that the Integrated Welder is "armed" if air pressure is indicated on the front panel air pressure gauge

CAUTION	Loud Noise Hazard
	<p>Sound level emissions of up to 102 dB have been measured using a standard test load. To prevent the possibility of hearing loss, use appropriate hearing protection.</p> <p>Sound level and frequency of the noise emitted during the ultrasonic assembly process may depend upon <b>a.</b> type of application, <b>b.</b> size, shape and composition of the material being assembled, <b>c.</b> shape and material of the holding fixture, <b>d.</b> welder setup parameters and <b>e.</b> tool design. Some parts vibrate at an audible frequency during the process. Some or all of these factors may result in sound levels of up to 102 dB. In such cases operators may need to be provided with personal protective equipment. See 29 CFR (Code of Federal Regulations) 1910.95 Occupational Noise Exposure. For all other countries, follow your local regulations.</p>

## 1.2.1 Intended Use of the System

The 2000 Series Integrated Welder houses all the components of an ultrasonic welding system. These are designed for a wide variety of welding or processing applications.

## 1.2.2 Safety Measures and Guards

The 2000 Series Integrated Welder, contains software-controlled electronic safety devices intended to prevent the machine from operating in a fashion harmful to the user. Start Switch and Emergency Stop controls are designed to prevent undesirable startup.

## 1.2.3 Emissions

When being processed, certain plastic materials can emit toxic fumes, gases or other emissions that can be hazardous to the operator's health. Where such materials are processed, proper ventilation of the workstation is required. Check your materials suppliers for recommended protection when processing their materials.

CAUTION	General Warning
	Processing of many materials, such as PVC, can be hazardous to an operator's health and could cause corrosion/damage to the equipment. Use proper ventilation and take protective measures.

## 1.2.4 Setting up the Workplace

Measures for setting up a workplace for safe operation of the ultrasonic welder are outlined in **Chapter 4: Installation and Setup** of your **Operating Manual**.

## 1.2.5 Regulatory Compliance

The Branson 2000 Series Integrated Welder is designed for compliance with the following regulatory and agency standards:

- ANSI Z535.1 Safety Color Code
- ANSI Z535.3 Criteria for Safety Symbols
- ANSI Z535.4 Product Safety Signs and Labels
- BS EN ISO 12100-1, Safety of Machinery - Basic concepts, general guidelines for design
- EN 55011 Limits and methods of measurement of radio disturbance of industrial, scientific and medical radio-frequency equipment
- EN 60204-1 Safety of Machinery - Electrical Equipment of machines
- EN 60529 Degrees of protection provided by enclosure
- EN 60664-1 Insulation coordination for equipment within low-voltage systems
- EN 61000-6-2 Electromagnetic Compatibility - Generic standards - Immunity for industrial environments
- EN 61310-2 Safety of Machinery - Indication, marking, actuation
- NFPA 70 National Electrical Code Article 670 Industrial Machinery
- NFPA 79 Electrical Standard for Industrial Machinery
- 29 CFR 1910.212 OSHA General Requirements for all machines
- 47 CFR Part 18 Federal Communication Commission

## 1.3 Warranty

For warranty information please reference the warranty section of Terms and Conditions found at: [www.emerson.com/branson-terms-conditions](http://www.emerson.com/branson-terms-conditions).

## 1.4 How to Contact Branson

Branson is here to help you. We appreciate your business and are interested in helping you successfully use our products. To contact Branson for help, use the following telephone numbers, or contact the field office nearest you (business hours from 8 a.m. to 4 p.m. Central and Eastern Time Zones):

- **North American Headquarters (all Departments):** (203) 796-0400
- **Parts Store (direct number):** (877) 330-0406
- **Repair department:** (877)-330-0405
- **For emergency after-hours service (5 p.m.-8 a.m. EST):** (203) 796-0500 (US phone numbers only)

Tell the operator which product you have and which person or department you need (see [1.5.3 Departments to Contact](#)). If you are calling after hours, please leave a voice message with your name and return telephone number.

### 1.4.1 Before Calling Branson for Assistance

This manual provides information for troubleshooting and resolving problems that could occur with the equipment (see [Chapter 4: Troubleshooting](#)). If you still require assistance, Branson Product Support is here to help you. To help identify the problem, use the following questionnaire which lists the common questions you will be asked when you contact the Product Support department.

Before calling, determine the following information:

1. Your company name and location.
2. Your return telephone number.
3. Have your manual with you. If troubleshooting a problem, refer to [Chapter 4: Troubleshooting](#)
4. Know your equipment model and serial numbers (found on a gray data label on the units). Information about the Horn (part number, gain, etc.) or other tooling may be etched into the tooling. Software- or firmware-based systems may provide a BOS or software version number, which may be required.
5. What tooling (horn) and booster are being used?
6. What are the setup parameters and mode?
7. Is your equipment in an automated system? If so, what is supplying the "start" signal?
8. Describe the problem; provide as much detail as possible. For example, is the problem intermittent? How often does it occur? How long before it occurs if you are just powering up? If an error is occurring, which error (give error number or name)?
9. List the steps you have already taken.
10. What is your application, including the materials being processed?
11. Have a list of service or spare parts you have on hand (tips, horns, etc.)
12. Notes: \_\_\_\_\_  
\_\_\_\_\_  
\_\_\_\_\_

## 1.5 Returning Equipment for Repair

Before sending equipment for repair, provide as much information with the equipment to help determine the problem with the system. Use the following page to record necessary information.

NOTICE	
	<p>To return equipment to Branson, you must first obtain an <b>RGA number</b> from a Branson representative, or the shipment may be delayed or refused.</p>

If you are returning equipment to Branson for repair, you must first call the Brookfield Repair department to obtain a **Returned Goods Authorization (RGA)** number. (If you request it, the repair department will fax a Returned Goods Authorization form to fill out and return with your equipment.)

**Branson Repair Department, C/O Zuniga Logistics, LTD**  
**12013 Sara Road, Killam Industrial Park**  
**Laredo, Texas 78045 U.S.A.**  
**direct telephone number: (877) 330-0405**  
**fax number: (877) 330-0404**

- Provide as much information as possible that will help identify the need for repair
- Carefully pack the equipment in original packing cartons
- Clearly label all shipping cartons with the RGA number on the outside of cartons as well as on your packing slip, along with the reason for return
- Return general repairs by any convenient method. Send priority repairs by air freight
- You must prepay the transportation charges FOB Laredo, Texas, U.S.A.

### 1.5.1 Get an RGA Number

RGA# \_\_\_\_\_

If you are returning equipment to Branson, please call the Repair Department to obtain a Returned Goods Authorization (RGA) number. (At your request, the Repair Department will fax an RGA form to fill out and return with the equipment.)

### 1.5.2 Record information about the Problem

Before sending equipment for repair, record the following information and send a copy of it with the equipment. This will greatly increase Branson's ability to address the problem.

1. Describe the problem; provide as much detail as possible.  
 For example, is the problem intermittent? How often does it occur? How long before it occurs after powering up?

---



---



---



---



---



---

2. Is your equipment in an automated system? NO / YES
3. If the problem is with an external signal, which signal? \_\_\_\_\_  
If known, include plug/pin # (e.g., P29, pin #3) for that signal: \_\_\_\_\_
4. What are the Weld Parameters?  
\_\_\_\_\_  
\_\_\_\_\_
5. What is your application? (Type of weld, plastic material, etc.)  
\_\_\_\_\_
6. Name and phone number of the person most familiar with the problem:  
\_\_\_\_\_  
\_\_\_\_\_
7. Contact the Branson office prior to shipping the equipment.
8. For equipment not covered by warranty, to avoid delay, include a Purchase Order.

**Send a copy of this page with the equipment being returned for repair.**

### 1.5.3 Departments to Contact

Call your local Branson Representative, or contact the Branson facility by calling, and asking for the appropriate department, as indicated in [Table 1.2 Branson Contacts](#) below.

**Table 1.2** Branson Contacts

What you need help with or information about	Whom to Call	At this Extension #
Information about new welding systems or components	Your local Branson Rep or Branson Customer Service	203-796-0400 Ext 384
Application and Setup questions on the welding system	Welding Applications Lab	203-796-0400 Ext 368
Application assistance on the Horns and Tooling	ATG Lab	203-796-0400 Ext 495
Technical questions about the welding system	Welding Product Support	203-796-0400 Ext 355, 551
Technical questions about Horns and Tooling	ATG Lab	203-796-0400 Ext 495
Ordering new parts	Parts Store	877-330-0406
RGA's, Request for Repair, Status of a Repair	Welding Repair Department	877-330-0405
System Automation/Hookup Information	Product Support	203-796-0400 Ext 355, 551

My Local Branson Representative's name is:

\_\_\_\_\_

I can reach this representative at:

\_\_\_\_\_

## 1.5.4 Pack and Ship the Equipment

1. Carefully pack the system in original packing material to avoid shipping damage. Plainly show the RGA number on the outside of cartons as well as inside the carton along with the reason for return. Make a list of all components packed in the box. **KEEP YOUR MANUAL.**
2. Return general repairs by any convenient method. Send priority repairs by air freight. Prepay the transportation charges FOB the repair site.

NOTICE	
	Items that are sent Freight Collect will be refused.

## 1.6 Obtaining Replacement Parts

You can reach Branson Parts Store at the following telephone numbers:

**Branson Part Store**

**direct telephone number: 877-330-0406**

**fax number: 877-330-0404**

Many parts can be shipped the same day if ordered before 2:30 p.m., Eastern time.

A parts list is found in [Chapter 7: Master Parts List](#) of this manual, listing descriptions and EDP part numbers. If you need replacement parts, coordinate the following with your purchasing agent:

- Purchase order number
- 'Ship to' information
- 'Bill to' information
- Shipping instructions (air freight, truck, etc.)
- Any special instructions (for example, "Hold at the airport and call"). Be sure to give a name and phone number
- Contact name information

---

## **Chapter 2: The 2000IW/IW+ Welder**

---

<b>2.1</b>	<b>Models Covered</b> .....	<b>14</b>
<b>2.2</b>	<b>Overview of these Models</b> .....	<b>15</b>
<b>2.3</b>	<b>Compatibility with Branson Products</b> .....	<b>18</b>
<b>2.4</b>	<b>Features</b> .....	<b>19</b>
<b>2.5</b>	<b>Front Panel Controls</b> .....	<b>20</b>
<b>2.6</b>	<b>Rear Panel</b> .....	<b>27</b>
<b>2.7</b>	<b>System Inputs/Outputs</b> .....	<b>29</b>
<b>2.8</b>	<b>Glossary</b> .....	<b>31</b>

## 2.1 Models Covered

This manual contains instructions for maintaining, repairing, troubleshooting and assembling/disassembling a 2000 IW and 2000 IW+ Series Integrated Welder for 1100, 2200 and 3300 watts.

## 2.2 Overview of these Models

The 2000IW and IW+ Series Integrated Welders are ultrasonic plastic joining systems. They are used for welding plastic parts together by staking, insertion, swaging and degating.

These welders are self contained, free standing welding systems designed for upright vertical operation. The IW and IW+ Welders are available in 2 power levels: 1100 Watts, and 2200 Watts. The IW+ is also available in 3300 Watts.

- For manual applications, welders can contain a base assembly with 2 Start Switches and an Emergency Stop knob
- For Automated applications, welders can contain a hub in place of the base assembly

A typical setup will be with a standard 40-inch column (4, 5 and 6 foot lengths are also available).

**Figure 2.1** 2000IW/IW+ Series Integrated Welder

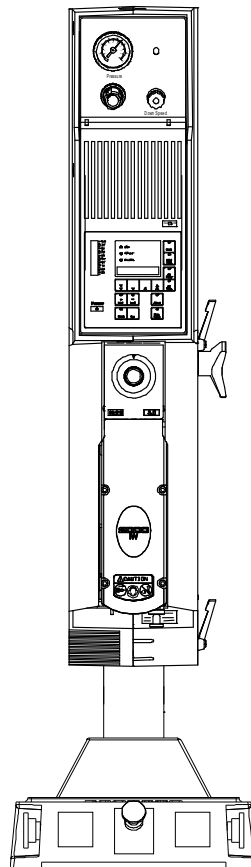

NOTICE	
	<p>It is advisable to have non standard length columns installed at the factory.</p>

An enclosure housing the carriage and slide system, the pneumatic system, the power supply and the control module. The Control Module consists of a control board and a keyboard/display board.

A linear optical encoder provides detailed weld distance information, IW+ only.

## 2.2.1 Carriage and Slide System

The carriage is driven by a double-acting air cylinder, mounted on a linear, ball-bearing slide. The slide system is based on eight sets of preloaded, permanently lubricated bearings. These provide consistent, precise alignment of the horn, smooth linear motion, and long-term reliability.

## 2.2.2 Pneumatic System

The pneumatic system consists of a solenoid valve, and air cylinder, and a Pressure Regulator with an air-pressure gauge. The carriage's rate of descent is adjusted by the Down Speed control on the welder's front panel. The rate of ascent is fixed.

As the carriage travels up and down, cooling air from the exhaust air of the solenoid valve is directed through the carriage to the converter.

## 2.2.3 Power Supply Module

The Power Supply Module converts conventional 50/60 Hz line current ultrasonic energy at the resonant frequency of your Converter-Booster-Horn Stack. The Module Controller ensures maximum reliability by terminating ultrasonic energy if the welder is operated under adverse conditions. This protects both the power supply module and other welder components. The controller also tracks and compensates for changes in horn frequency, if necessary. These changes may occur due to increased temperatures, wear on the horn face, or material buildup on the horn.

## 2.2.4 Control Module

The Control Module consists of a Controller board and a keyboard/display board. It controls the power supply module and the welder's pneumatic functions. The keyboard/display board allows the user to change parameters via the front panel displays and switches.

## 2.2.5 Linear Optical Encoder, a 2000IW+ only feature

The Linear Optical Encoder is a sensing device that tracks carriage movement. The resolution of the encoder is 0.0001 in / 0.0025 mm.

NOTICE	
	The linear optical encoder reading will vary from the actual distance the carriage travels by no more than 1/4 in / 6 mm, due to the setting of the Upper Limit Switch (ULS). This distance is consistent from cycle to cycle.

Information from the linear optical encoder is used:

- To determine the relative position of the carriage at any point during the weld cycle
- To terminate the weld by absolute distance, the total distance the carriage travels from an upper limit position (ULS) to a preset lower limit position

- To terminate the weld by collapse distance, the total distance the carriage travels from the Dynamic Trigger Switch (TRS) to a preset lower limit position

### **2.2.6 Upper Limit Switch**

The optical Upper Limit Switch (ULS) signals the control circuits in the controller that the carriage has returned to the top of its stroke and the welder is ready to start another weld cycle.

The controller uses this ULS signal to perform various control functions. For example:

- Indexing control, in automated systems, the Ready signal developed by the controller after the ULS is activated can be used by external devices to prevent movement of the material handling equipment (indexing) when the horn is not fully retracted
- Electronic pretriggering, the controller can use the ULS signal to activate ultrasonic energy before the horn contacts the workpiece. Pretriggering is used with large of difficult-to-start horns and in a variety of applications

### **2.2.7 User I/O Connector**

External controls and devices, such as ALARMS, WELD ON and EXTERNAL RESET signals, are available through +24V DC interface on the back panel of the welder. In addition, a READY signal is available as both +24V DC and isolated contact closure. Using this interface, selected faults or weld errors sensed by the welder can be communicated outside the welder for monitoring cycles and sorting suspect workpieces.

### **2.2.8 Dynamic Triggering and Follow-Through**

Many weld applications require that force be applied to the workpiece before ultrasonic energy is activated. To achieve this, the welder contains a Dynamic Triggering Mechanism, located between the air cylinder and the carriage. The Dynamic Triggering Mechanism initiates (triggers) ultrasonic energy after a preset force is applied to the workpiece. Dynamic follow-through maintains a consistent force on the workpiece during the weld collapse. The system helps provide uniform weld quality.

The calibrated TRIGGER PRESSURE control, located on the front panel, allows you to record and duplicate the dynamic triggering force.

## 2.3 Compatibility with Branson Products

The 2000IW/IW+ Series Integrated Welders are compatible for use with either a standard base or a hub for automation. The CJ20 converter is used for the 1100, 2200, and 3300 Watt units.

## 2.4 Features

The 2000IW/IW+ Series Integrated Welders can perform ultrasonic welding, inserting, staking, spot welding, swaging, degating, and continuous ultrasonic operations. It is designed for automated, semi-automated and/or manual production operations. The following list describes the control features of the welder.

**Afterburst:** This feature allows you to turn on the ultrasonics after the weld and hold steps to reliably release parts from the horn.

**Alarms, Process:** IW+ only, These are set values used for part quality monitoring.

**Autotuning:** Ensures that the welder is running at peak efficiency.

**Cycle Aborts:** These are user programmed conditions (ground detect, IW only) at which the cycle is terminated. These can be used as safety limits to save wear and tear on the system and your tooling.

**Downspeed:** Sets the advance speed of the horn towards the workpiece.

**English (USCS)/Metric Units:** This feature allows the welder to be programmed in the local units in use.

**Horn Down Display, IW+ only:** During Horn Down, the absolute Distance is displayed digitally so that you can determine correct values for settings.

**Horn Down Mode:** A manual procedure used to verify system setup and alignment.

**Limits:** IW+ only, A class of user-definable process alarms that alert you if a part falls into a range that you classified as reject parts.

**Memory:** When Memory is turned on, weld parameters at the end of the cycle will be entered.

**Membrane Keyboard:** For high reliability and immunity from factory dust and oils.

**Pretrigger:** This feature allows you to turn on the ultrasonics before contact with the part to increase performance.

**Ramp Starting:** The starting of the Power Supply Module and horn is done at the optimum rate to reduce electrical and mechanical stress on the system.

**Seek:** Ensures operation at resonance, minimizes tuning errors, and operates the stack at low amplitude (approximately 5%), then provides a means of sensing and storing the resonant operating frequency.

**Start-up Diagnostics:** At start-up, the controls test the major system components.

**Timed Seek:** When turned ON, will do a Seek once every minute to update horn resonant frequency to memory. This is especially useful when the welding process affects the actual temperature of the horn, causing a resonant frequency shift.

## 2.5 Front Panel Controls

Figure 2.2 Front Panel Controls, IW

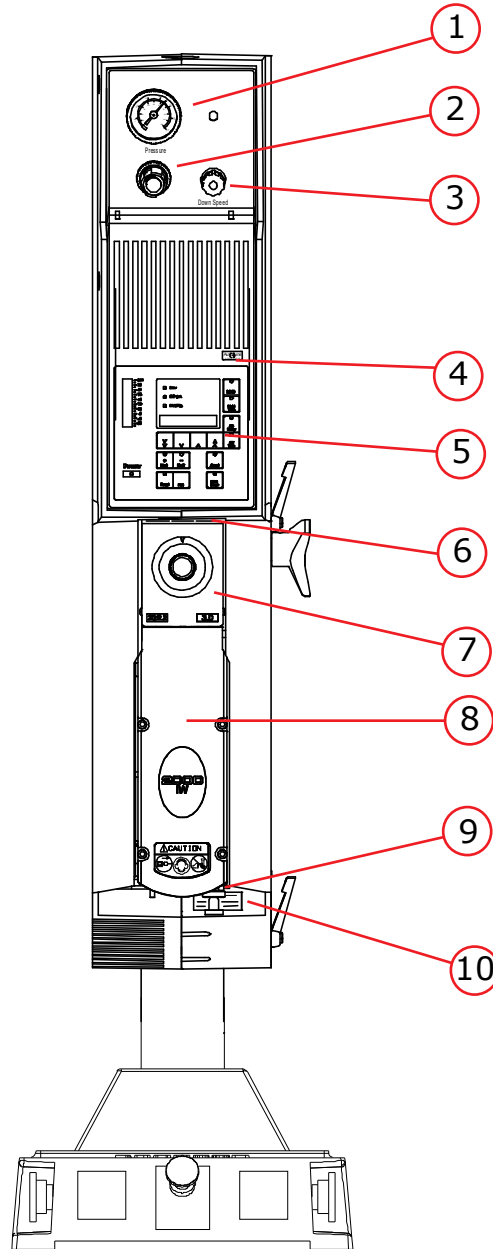

Table 2.1 Front Panel Controls

Item	Name	Function
1	Pressure Gauge	Indicates the amount to air pressure applied to cylinder; dual-calibrated at 0-100psig/0-700kPa.
2	Pressure Regulator	Adjusts amount of air pressure applied to cylinder; range of 5-100 psig/35-700kPa. Pull to set, push to lock.

**Table 2.1** Front Panel Controls

Item	Name	Function
3	Down Speed Control	Controls rate of carriage descent, multi-turn color coded, each turn calibrated at 0-9. Pull red locking ring to set; push locking ring to lock. Return rate is fixed.
4	Autotune Label	Refer to <a href="#">6.1.4 Manual Tuning</a> of your Operating Manual.
5	Front Panel Displays	Refer to next section.
6	Stroke Indicator	Provides a quick method of determining relative carriage travel during a weld cycle; indicates 0-4 in. (0-100 mm)
7	Trigger Pressure Control	Selects dynamic triggering pressure; calibrated 1-24 in half-steps/48 detents corresponding to a force range of 15-200 lbs/67-890 N.
8	Carriage Door	Provides access to the converter-booster-horn stack; secured by 4 captive hex screws.
9	Mechanical Stop Locking Nut	Locks the mechanical stop to desired depth.
10	Mechanical Stop	Limits the distance the carriage travels to prevent the horn from contacting the fixture or nest when no workpiece is in place; adjustment is approximately 0.04 in/1 mm per rotation.

This multi-turn control is calibrated in color rings, visible in slots.

**Figure 2.3** Front Panel Displays, IW

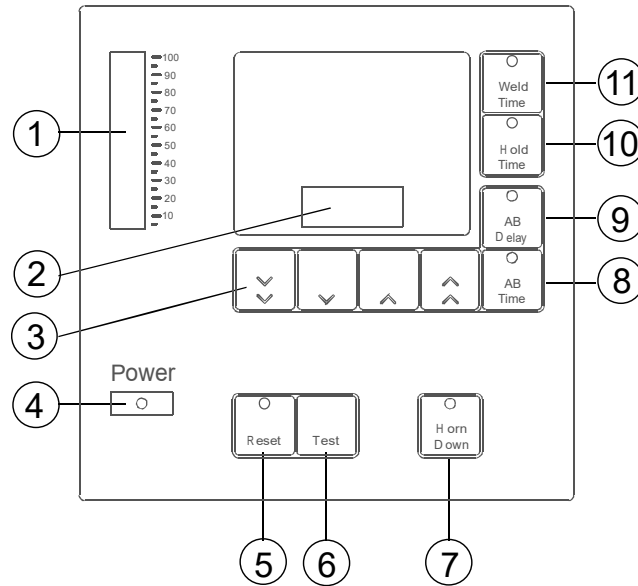

**Table 2.2** Front Panel Displays, IW

Item	Name	Function
1	Power Bargraph	This 20 segment bargraph displays the power level during the Test mode; or the power applied to the workpiece during a weld cycle. While in READY state, the graph displays the peak power of the last weld cycle. These readings can be expanded by altering DIP switch settings. When using the 2x scale, the uppermost segment will blink. Refer to Section 4.11.1 'Setting DIP Switches', of your Operating Manual for further information about DIP settings.
2	Numeric Display	During a weld cycle, indicates the current weld state code, if enabled, or the currently selected parameter's value. At the end of the weld cycle, it displays alarms.
3	Up/Down Switches	Once you have selected weld parameters to change, these four switches increase or decrease your selected parameters displayed in the NUMERIC DISPLAY. From left to right, these switches are referred to as the FAST DOWN switch, the SLOW DOWN switch, the SLOW UP switch, and the FAST UP switch. Pressing these switches will have no effect until you have selected parameters to change. These switches will be disabled when Display Lock is active.
4	Power Indicator	Indicates that power to the welder is ON.
5	Reset Switch	Resets any resettable or latchable alarm condition (indicated by the switch LED blinking). Holding RESET prevents a weld cycle from starting. Releasing RESET returns the welder to the READY state, if there are no non-resettable errors.

**Table 2.2** Front Panel Displays, IW

Item	Name	Function
6	Test Switch	Activates ultrasonic power and places the ultrasonic power supply module into Test (Autotune) mode for approximately 6 seconds. While this switch is pressed, power displays on both the NUMERIC DISPLAY and the POWER BARGRAPH. When you release TEST, the welder returns to the READY state. You can select the scale factor for Test mode by setting the Test Scale Multiplier DIP switch to 1x or 2x. Refer to Section <b>4.11.1 'Setting DIP Switches'</b> , of your Operating Manual for further information about DIP settings.
7	Horn Down Switch	Selects the HORN DOWN mode. When pressed, the switch LED will light. Pressing the START SWITCHES while in the Horn Down mode will bring the carriage down without triggering ultrasonics. Pressing the switch again will de-select HORN DOWN mode.
8	AB Time Switch	Selects the Afterburst TIME parameter for modification when display lock is inactive; displays the AB TIME parameter in the NUMERIC DISPLAY, and lights the AB TIME switch LED.
9	AB Delay Switch	Selects the Afterburst DELAY parameter for modification when display lock is inactive; displays the AB DELAY parameter in the NUMERIC DISPLAY, and lights the AB DELAY switch LED.
10	Hold Time Switch	Selects the Hold Time parameter for modification when display lock is inactive; displays the Hold parameter in the NUMERIC DISPLAY, and lights the Hold Time switch LED.
11	Weld Time Switch	Selects the Weld Time parameter for modification when display lock is inactive; displays the Weld parameter in the NUMERIC DISPLAY; and lights the Hold Time switch LED.

**Figure 2.4** Front Panel Displays, IW+

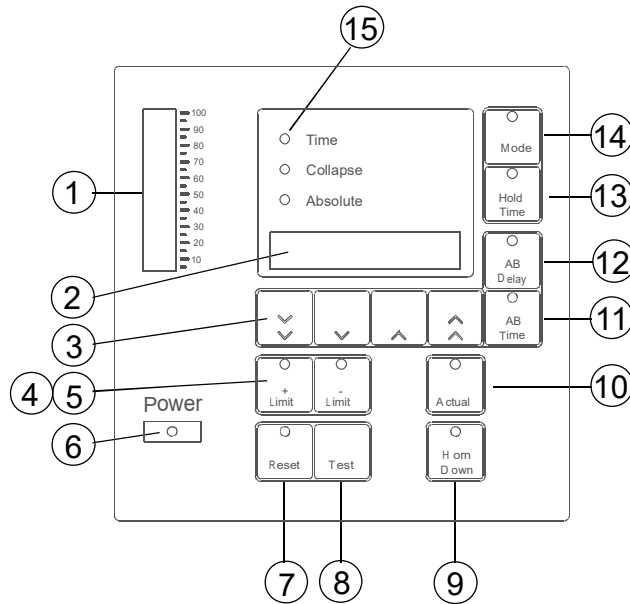

**Table 2.3** Front Panel Displays IW+

Item	Name	Function
1	Power Bargraph	This 20 segment bargraph displays the power level during the Test mode; or the power applied to the workpiece during a weld cycle. While in READY state, the graph displays the peak power of the last weld cycle. These readings can be expanded by altering DIP switch settings. When using the 2x scale, the uppermost segment will blink. Refer to Section <b>4.11.1 'Setting DIP Switches'</b> , of your Operating Manual for further information about DIP settings.
2	Numeric Display	During a weld cycle, indicates the current weld state code, if enabled, or the currently selected parameter's value. At the end of the weld cycle, it displays alarms.
3	Up/Down Switches	Once you have selected weld parameters to change, these four switches increase or decrease your selected parameters displayed in the NUMERIC DISPLAY. From left to right, these switches are referred to as the FAST DOWN switch, the SLOW DOWN switch, the SLOW UP switch, and the FAST UP switch. Pressing these switches will have no effect until you have selected parameters to change. These switches will be disabled when Display Lock is active.
4	+ Limit Switch	A 2000IW+ only feature - selects the maximum value for the mode you are in. When pressed, the switch LED will light. This switch is only active after you have pressed MODE.

**Table 2.3** Front Panel Displays IW+

Item	Name	Function
5	- Limit Switch	A 2000IW+ only feature - selects the minimum value for the mode you are in. When pressed, the switch LED will light. This switch is only active after you have pressed MODE.
6	Power Indicator	Indicates that power to the welder is ON.
7	Reset Switch	Resets any resettable or latching alarm condition (indicated by the switch LED blinking). Holding RESET prevents a weld cycle from starting. Releasing RESET returns the welder to the READY state, if there are no non-resettable errors.
8	Test Switch	Activates ultrasonic power and places the ultrasonic power supply module into Test (Autotune) mode for approximately 6 seconds. While this switch is pressed, power displays on both the NUMERIC DISPLAY and the POWER BARGRAPH. When you release TEST, the welder returns to the READY state. You can select the scale factor for Test mode by setting the Test Scale Multiplier DIP switch to 1x or 2x. Refer to Section <b>4.11.1 'Setting DIP Switches'</b> of your Operator Manual for further information about DIP settings.
9	Horn Down Switch	Selects the HORN DOWN mode. When pressed, the switch LED will light and the NUMERIC DISPLAY will show the current linear encoder reading. If you have selected USCS units, 0.0000" (representing inches) will appear on the NUMERIC DISPLAY; if you have selected SI units, 0.0000 (representing millimeters) will appear. Pressing the START SWITCHES while in the Horn Down mode will bring the carriage down without triggering ultrasonics. Pressing the switch again will de-select HORN DOWN mode.
10	Actual Switch	A 2000IW+ only feature - selects for display the actual value for the previous weld. Each succeeding press will display the actual value of each of the three modes in turn, displaying the actual time or actual distance and lighting the relevant MODE INDICATOR LED. The fourth press will return the welder to the READY state. Although the MODE INDICATOR LEDs change with each press of ACTUAL, the welder mode does not change. Pressing MODE will display the current mode again.
11	AB Time Switch	Selects the Afterburst TIME parameter for modification when display lock is inactive; displays the AB TIME parameter in the NUMERIC DISPLAY, and lights the AB TIME switch LED.

**Table 2.3** Front Panel Displays IW+

Item	Name	Function
12	AB Delay Switch	Selects the Afterburst DELAY parameter for modification when display lock is inactive; displays the AB DELAY parameter in the NUMERIC DISPLAY, and lights the AB DELAY switch LED.
13	Hold Time Switch	Selects the Hold Time parameter for modification when display lock is inactive; displays the Hold parameter in the NUMERIC DISPLAY, and lights the Hold Time switch LED.
14	Mode Switch	<p>a 2000IW+ only feature - selects between Time and Collapse and Absolute Distance modes; changes the display for the selected mode, and allows for changes in mode or mode parameters when Display Lock is inactive.</p> <p><b>NOTICE</b> In Collapse or Absolute Distance Modes the weld time parameter acts as an overriding condition. Ensure Time is setup to allow for the collapse or absolute distances to be attained during a weld.</p>
15	Mode Indicator LEDs	A 2000IW+ only feature - light once you have selected the mode you wish to alter; indicate the mode selected.

## 2.6 Rear Panel

The grayed out portion shows placement of the optional Accessory Input/Output (1), and Ground Detect inputs (2, 3) and the position of the mounting plate supplied in their respective kits (see below).

**Figure 2.5** Rear Panel

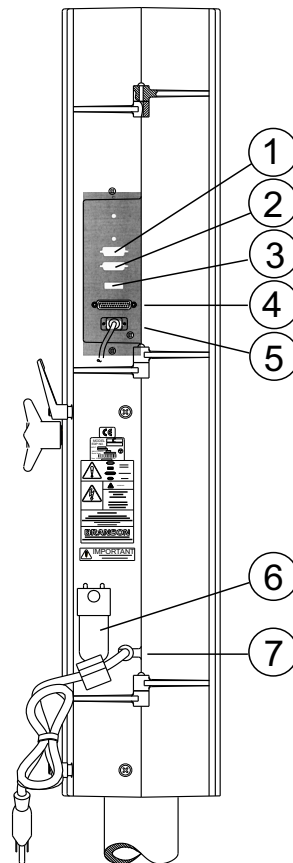

**Table 2.4** Rear Panel Connectors

Item	Description	Function
1	Accessory Input/Output	An advance feature option that allows connection of Power Out, Memory, Seek, Frequency, Frequency Offset, Power Supply Module Status Outputs, Amplitude Output and Amplitude Control Input. Requires Accessory Input/Output kit 101-063-721. 15 pin male connector.

**Table 2.4** Rear Panel Connectors

Item	Description	Function
2	Ground Detect (15 pin female)	An optional 2000IW only feature - allows ultrasonic energy to be turned off when the horn comes in contact with your electrically isolated fixture or anvil. Requires Ground Detect Kit, 101-063-343. Connector 2 is 15 pin female, connector 3 is 3 pins.
3	Ground Detect (3 pins)	
4	User I/O, Alarm Connector	25 pin D-shell connector provides a +24V DC interface for external controls and devices. ALARMS, WELD ON and EXTERNAL RESET signals are available. In addition, a READY signal is available as both +24V DC and isolated contact closure. Using this connector, selected faults or weld errors sensed by the welder can be communicated outside the welder for monitoring cycles and sorting suspect workpieces. Connector 4 is a 25 pin female.
5	Start Connector	Connects the welder to its base or to customer supplied start signals. Connector 5 is a 9 pin male.
6	Air Filter	Filters contaminants from the air entering the welder.
7	Line Cord	Connects the welder to your power source.

## 2.7 System Inputs/Outputs

The inputs provided to the welder are used to control the weld cycle and monitor the 2000IW/IW+ hardware.

### 2.7.1 START SWITCHES/START Signal - START Connector

These inputs are used to start the weld cycle. To start a weld cycle, both START SWITCH inputs must become active within 100 (IW) to 200 (IW+) ms of each other, and remain active until TRS activates, or an error will be generated and no weld will be performed.

Errors will also be generated if the START SWITCHES do not remain active until the TRS input becomes active (for maintained software), or are not inactive within 4 seconds after the solenoid valve drive circuits have been disabled.

**Figure 2.6** Base, Showing Start Switches and Base Cable

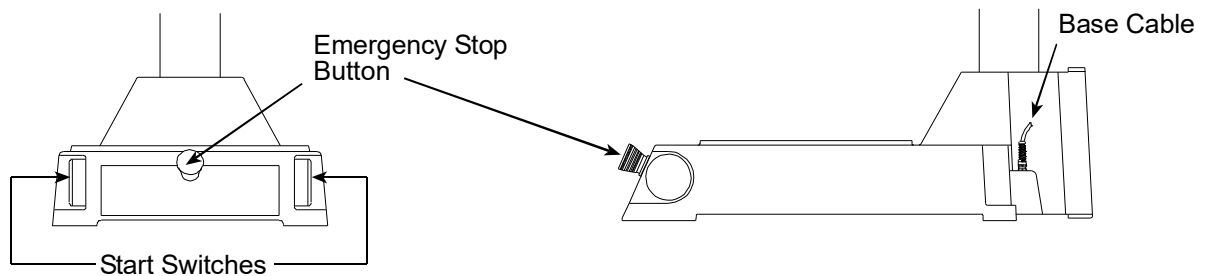

### 2.7.2 EXTERNAL RESET - ALARM (User I/O) Connector

This input, when activated, will simulate pressing RESET (refer to Front Panel Displays [Figure 2.3](#) and [Figure 2.4](#), callout 5, IW, 7 IW+). You cannot start a weld cycle if the EXTERNAL RESET line is active.

### 2.7.3 READY Signal - ALARM Connector

The welder uses the Upper Limit Switch (ULS) input to determine when the carriage has started to descend and when it has reached its "home" position on its return at the end of the weld cycle.

The controller evaluates other system conditions as well before generating the READY signal. It evaluates if any alarm conditions exist. Monitoring this signal indicates that the welder is at rest and it is ready to cycle (for example not in TEST, HORN DOWN, latched alarm condition or system fault).

### 2.7.4 GENERAL ALARM - Alarm Connector

GENERAL ALARM is a signal which indicates that an alarm has been sensed. Resetting alarms and resolving system faults clears this alarm signal. Refer to Section [4.3.1 Alarm Codes and Error Messages](#) for further information.

## 2.7.5 WELD ON Signal - Alarm Connector

The WELD ON signal indicates you are in the Weld Time portion of the cycle and that TRS is active. This signal indicates when a start signal can be released.

In any of the following situations, an error will be generated:

- The input becomes inactive while the welder is in the READY state
- The input does not become inactive within 4 seconds after the solenoid valves are activated
- The input becomes active before weld timing begins during a weld cycle
- The input does not become active within 4 seconds after the solenoid valves are deactivated

## 2.8 Glossary

The following terminology may be encountered when using or operating a 2000-series ultrasonic welding system. Some of these terms may not be available in all Controls (Power Supply model) configurations:

**AB Amplitude:** The amplitude at the horn face during the afterburst step.

**AB Delay:** Time delay between the end of the hold and the start of afterburst.

**AB Time:** The time duration of the afterburst.

**Absolute Distance:** The distance the horn has travelled from home.

**Absolute Mode:** A mode of operation in which the weld is terminated when a user-specified distance from the home position has been reached.

**Absolute Position:** The position of the Actuator from the home position.

**Accept-as-is:** A disposition permitted for a nonconforming item when it can be established that the item is satisfactory for its intended use without violating safety or functional requirements.

**Actual:** A reported value that occurred during the weld cycle. The converse is the set parameter that was requested during the setup.

**Actuator:** The section of the Integrated Welder that houses the converter, booster, and horn assembly in a rigid mounting allowing it to move up and down either mechanically or pneumatically to apply a predetermined pressure on the workpiece.

**Afterburst (AB):** Ultrasonic energy applied after the hold step. Used to break away sticking parts from the tooling.

**Alarm Beeper:** An audible signal that sounds when a general alarm has occurred.

**Amplitude:** The peak-to-peak movement at the horn face. Always expressed as a percentage of the maximum.

**Amp Control:** The ability to set amplitude digitally or by an external control.

**Automatic:** A pretrigger condition indicating that pretrigger engages when the actuator leaves the upper limit switch.

**Beep:** An audible signal produced by the Branson control board. Used to alert the operator to an unexpected condition or that trigger has been reached.

**Booster:** A one-half wavelength long resonant metal section mounted between the converter and horn, usually having a change in cross-sectional area between the input and output surfaces. Mechanically alters the amplitude of vibration at the driving surface of the converter.

**Clamping Force:** The pressure exerted by the horn on the workpiece.

**Cold Start:** A user operation to establish a setup to a new, initial minimum set of weld parameters. Refer to *Chapter 6, Section "Resetting the System"*, of your Operating Manual. **Note:** Use carefully.

**Collapse Distance:** The vertical distance your part will be collapsed before termination of ultrasonics.

**Collapse Mode:** A mode of operation in which the weld is terminated when the part has been collapsed by a user-specified distance.

**Custom Logic:** Allows the operator to choose either High (24V) or Low (0V) logic for switches to be used in interfacing the welder to an automated system.

**Cycle Aborts:** There are no cycle aborts except Ground Detect, which is available in IW only.

**Downspeed:** The rate of speed of the actuator from the home position to the part.

**General Alarm:** An alarm that occurs due to a system fault and/or tripping a limit.

**Ground Detect Mode:** IW only, In this mode of operation, ultrasonics are terminated after detection of a ground condition between the horn and fixture or anvil.

**Horn Down:** A mode in which ultrasonics are locked out and the user can advance the Actuator for setup and alignment.

**Linear Encoder:** Provides carriage distance measurement during the welder cycle. IW+ only.

**Pretrigger:** The setting that causes ultrasonics to start before contact with the part.

**Ready Position:** State in which the welder is retracted and ready to receive the start signal.

**Required:** State used with limits indicating that a reset will be required when the limit is exceeded. The reset is accomplished by using the reset key on the front of the Integrated Welder, or by external reset at the User I/O.

**Reset Required:** State used with alarms indicating that a reset will be required before a cycle can be run. The reset is accomplished by using the reset key on the front of the Integrated Welder, or by external reset at the User I/O.

**Scrub Time:** The amount of time after detection of a ground condition (option IW only) to the termination of ultrasonics.

**Seek:** A setting where ultrasonics are on at 5% amplitude for the purpose of finding the resonant frequency of the stack.

**Stack:** Converter, Booster, and Horn.

**Test Scale:** The magnification of the power bar scale on the front panel while the Test key is pushed.

**Time Mode:** Terminates the ultrasonics at a user-specified time. **Note:** In Collapse or Absolute Distance Modes the weld time parameter acts as an overriding condition. Ensure Time is setup to allow for the collapse or absolute distances to be attained during a weld.

**Timeout:** A time at which the ultrasonic energy terminates if the main control parameter has not been reached.

**Trigger Beeper:** An audible signal sounded when the trigger is made.

**Upper limit switch (uls):** A switch when activated indicates the actuator is in the home position.

**User-defined limits:** IW+ only, for process resultants, where – is the user-defined lower limit, and + is the user defined upper limit:

-/+ Time: The weld time reached during the weld.

-/+ Abs D: The absolute distance from the Home position reached during the weld.

-/+ Col D: The collapse distance reached during the weld.

**Weld Time:** The time for which ultrasonics are on.

---

## **Chapter 3: Schematics**

---

<b>3.1</b>	<b>Introduction . . . . .</b>	<b>34</b>
<b>3.2</b>	<b>2000IW/IW+ Main Interconnect Schematic . . . . .</b>	<b>35</b>
<b>3.3</b>	<b>2000IW/IW+ Electrical Assemblies. . . . .</b>	<b>36</b>

## 3.1 Introduction

The Branson 2000 Series Integrated Welders, IW and IW+ Models, are self-contained ultrasonic plastics assembly systems that combine power supply, controls, indicators, and welding stand in a compact bench unit. Its compact footprint conserves work space. It can be used for ultrasonic welding, inserting, staking, spot welding, swaging, and degating thermoplastic parts. It can be operated manually, semi-automated or automated systems.

The Integrated Welder's control system is microprocessor-based, and controls the welding process while providing a level of user interface through a membrane keypad and alpha-numeric display. It employs fan-forced cooling is intended for vertical placement.

The front panel display and user controls are intended to be accessible from a comfortable position for an end user (operator), which means that the unit should be installed approximately 3 feet off the floor.

<b>CAUTION</b>	<b>Heavy Object</b>
	The welder weighs approximately 145 pounds; use care when moving and performing maintenance.

### This Section Contains:

2000W/IW+ Main Interconnect Schematic - showing the welder's internal and external electrical connections.

2000IW/IW+ Electrical Assemblies - contains circuit descriptions, schematics and/or assembly drawings, and Branson part numbers.

2000IW/IW+ Pneumatic System - contains the following: schematic; circuit description and Branson part numbers.

## 3.2 2000IW/IW+ Main Interconnect Schematic

Figure 3.1 2000IW/IW+ Main Interconnect Schematic

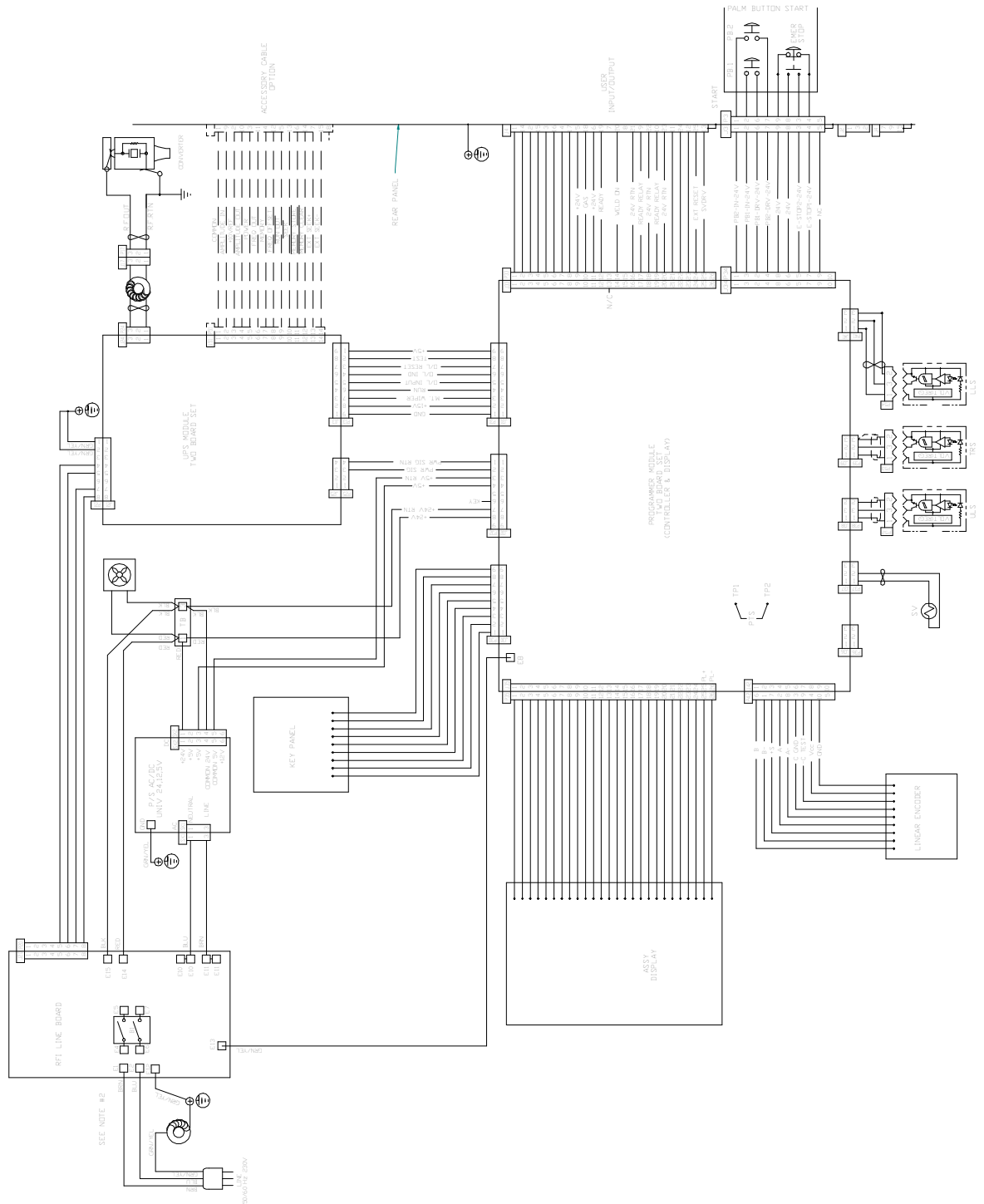

## **3.3 2000IW/IW+ Electrical Assemblies**

### **3.3.1 Circuit Descriptions**

The Integrated Welder contains the following modules:

- Line Board
- Control Module (Controller board and Display Board)
- Ultrasonic Power Module
- DC Power Module
- User I/O

The following sections contain descriptions for each module.

#### **Line Board**

The Line Board performs the dual function of providing RFI filtering for the line voltage input to the Integrated Welder, and controlling the electrical current surge to the ultrasonic Power Supply Module at power up until the inrush current limiter relay engages. The filtering also blocks ultrasonic signals from entering the AC main line.

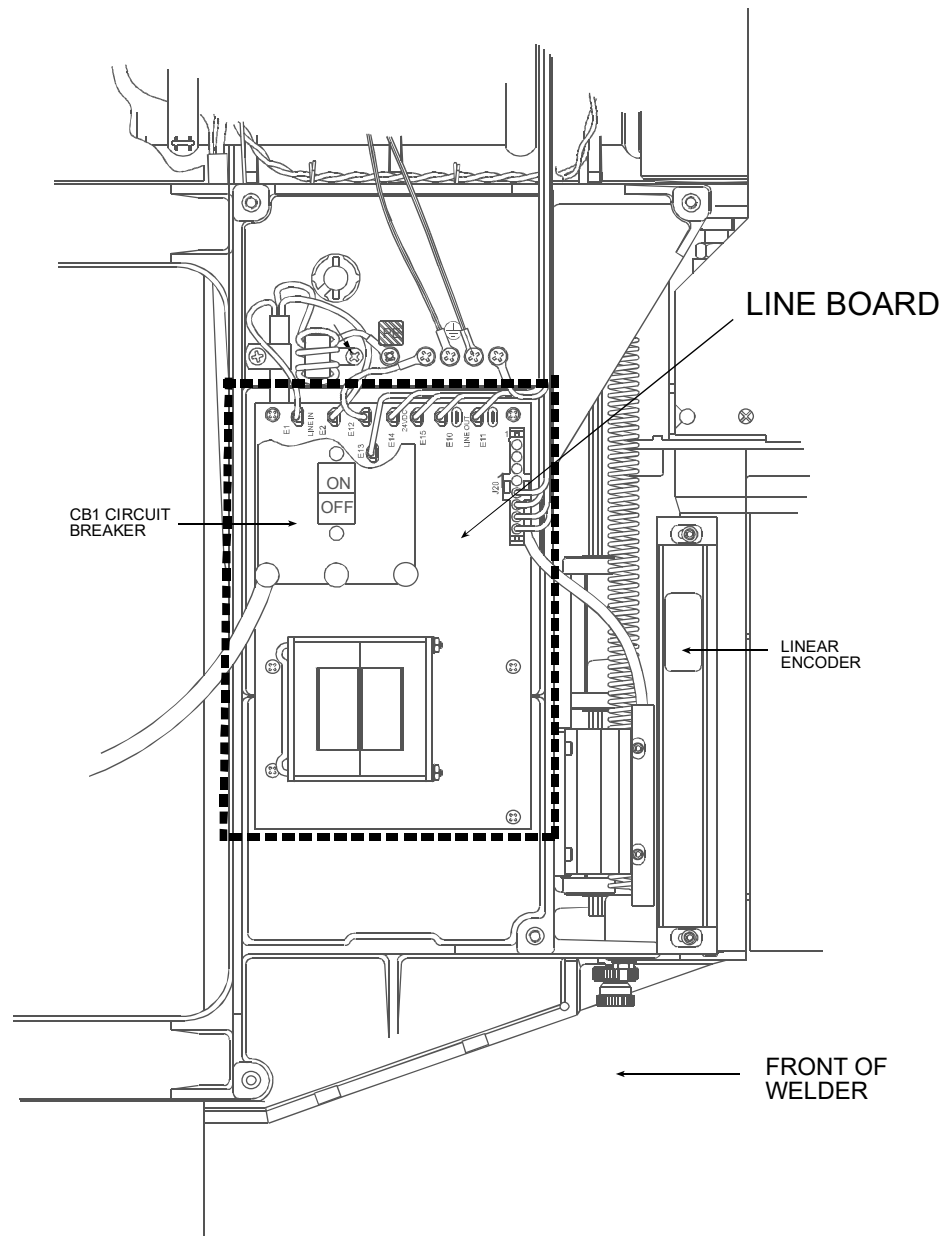
**Figure 3.2** 2000IW/IW+ Line Board Location

## System Control Module

The System Control Module consists of the Controller board and the Keyboard/Display board. It performs the following functions:

- Responding to start and stop signals
- Responding to alarm and reset signals
- Responding to user input from the front panel
- Activating and monitoring ultrasonics
- Provides information for Front Panel Displays
- Generate alarms
- Control communications

**Figure 3.3** IW/IW+ Control Module, Controller Board, Top and Side View

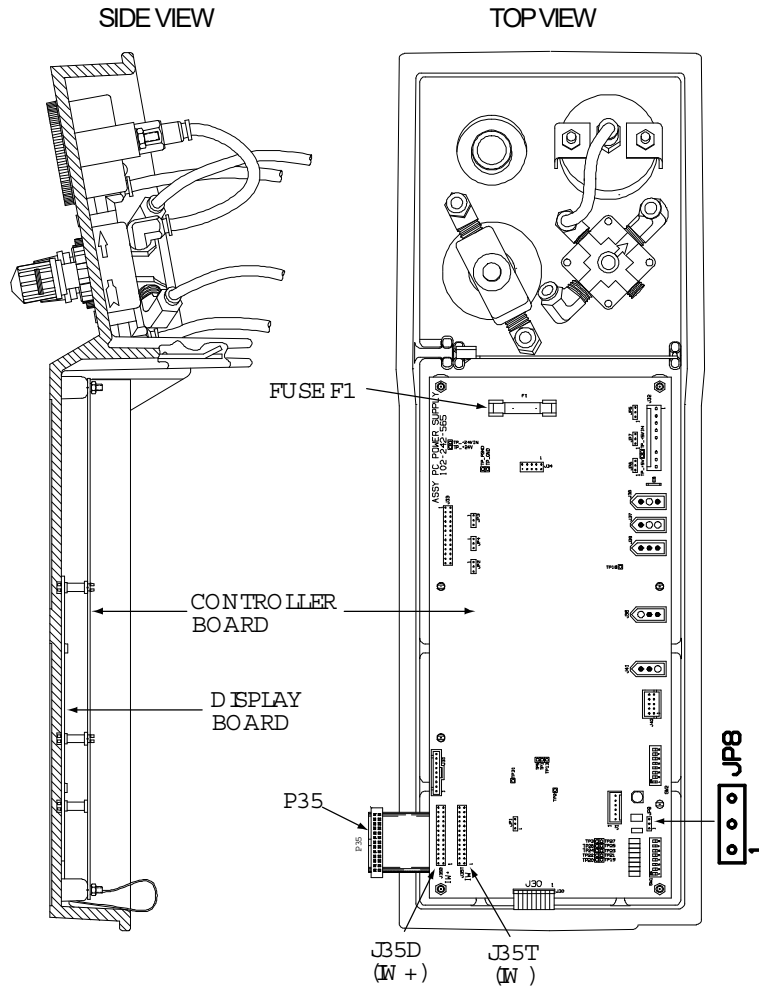

**Table 3.1** IW/IW+ Control Module Connector Assignments

Connector	IW+ 100-246-1173 or 100-246-1452	IW 100-246-1190 or 100-246-1453
P35	J35D	J35T
JP8	Pins 1 and 2	Pins 2 and 3

**Table 3.2** Control Module Part Number

Description	Part Number
Display Board, IW	100-242-1201R
Display Board, IW+	100-242-1202R
Kit, Controller 2000 IW and IW+	101-063-718

## Ultrasonic Power Supply Module

The Ultrasonic Power Supply Module generates ultrasonic energy at the resonant frequency of your Converter-Booster-Horn Stack. The Ultrasonic Power Supply Module contains three main circuits.

- **320VDC Power Supply:** converts AC line voltage to +320VDC for the output power devices.
- **Output circuit:** matches the impedance of the output power device to the Converter-Booster-Horn Stack; and provides feedback to the Control circuit.
- **Control circuits:** perform the following functions:
  - Provide drive signal to output power device.
  - Determine true percentage of ultrasonic power used over a range of amplitudes.
  - Allows control of the resonant frequency.
  - Control starting amplitude.
  - Provide overload protection for the Ultrasonic Power Module.
  - Store operating frequency of last weld (frequency memory) and use the stored frequency as a starting point for the next weld.
  - Check and update frequency memory on start-up.
  - Provide switch-selective starting ramp times (Start).

**Figure 3.4** 2000IW/IW+ Ultrasonic Power Module

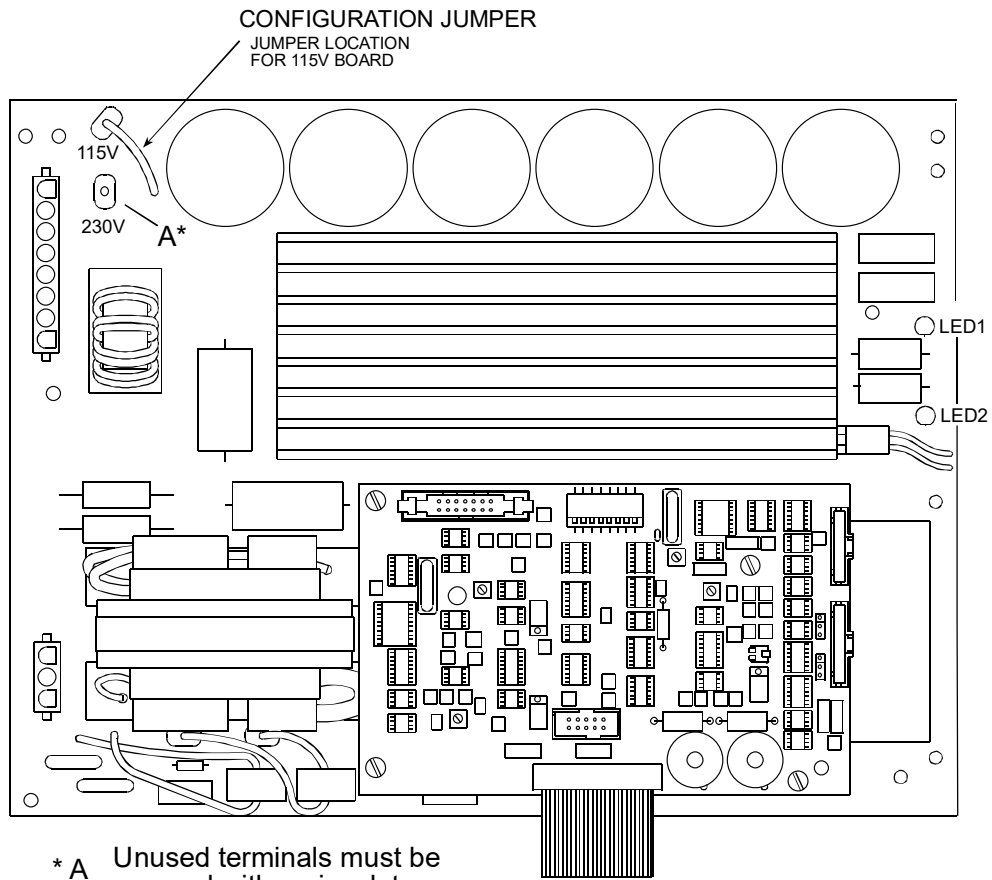

\* A Unused terminals must be covered with an insulator

The jumper configuration shown above is for 100 to 120VAC operation of the 1.1kW module. For 220 to 240VAC operation, move the jumper to the 230V lug (1.1kW module only).

Shown below is jumper placement for 200VAC to 240VAC operation of the 2.2kW module only.

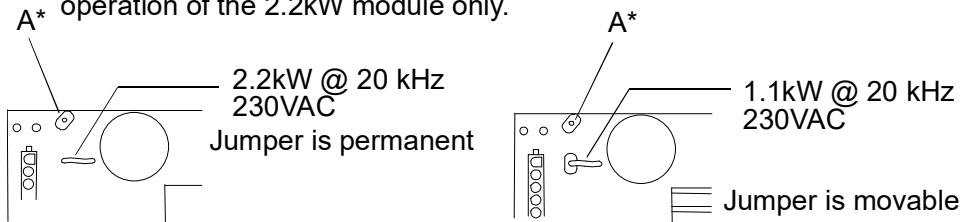

## DC Power Module

The Switching DC Power Module rectifies, filters, and regulates the AC voltages from the Line Transformer into DC voltages for the System Control Module.

**Figure 3.5** DC Power Module

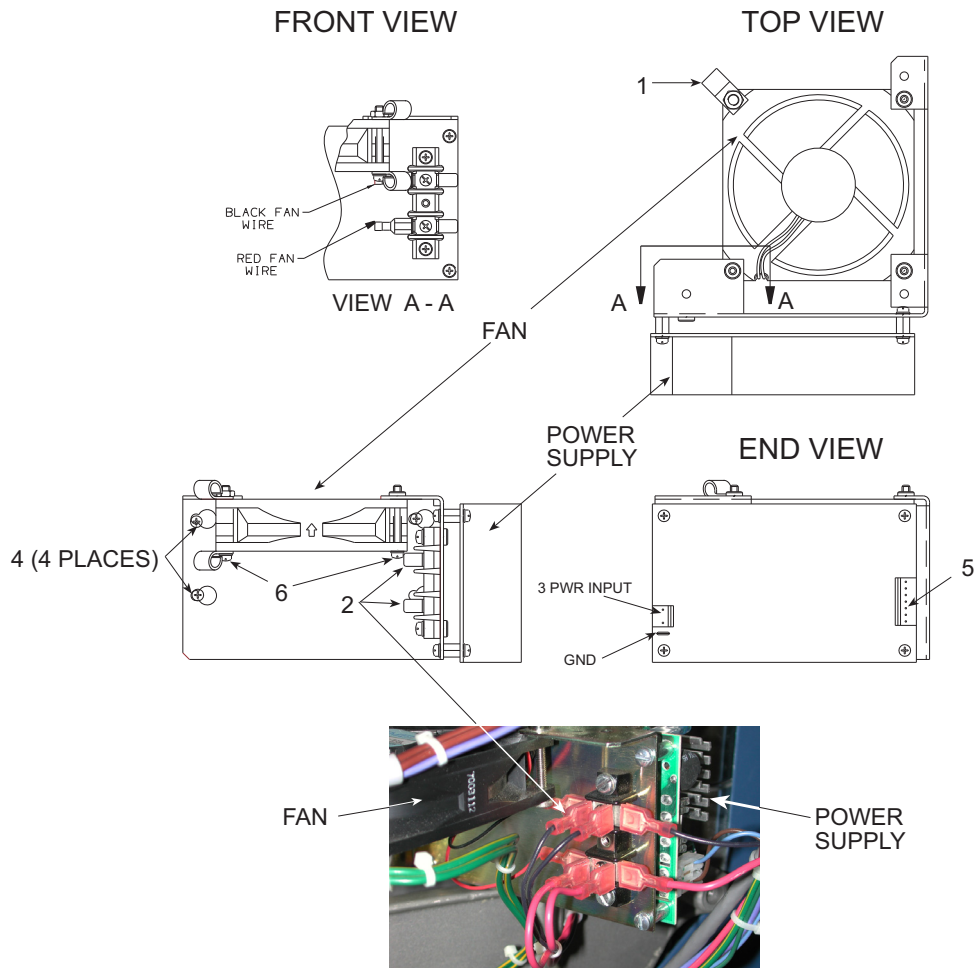

### 3.3.2 User I/O

The Alarm Connector provides status outputs and an EXTERNAL RESET switch connection to customer supplied controls. Connection is via a J971 cable from the 25 pin connector on the welder's rear panel. The cable is available in 8 ft./2.5 m, 15 ft./4.5 m, or 25 ft./7.5 m lengths.

The EXTERNAL RESET switch operates in exactly the same manner as the front panel RESET switch, applying +24V DC to the EXTERNAL RESET input (pin 25) for a minimum of 20 ms will reset the welder.

The status outputs available from the interface are SOLENOID OUTPUT (pin 13), GENERAL ALARM (pin 18), READY (signal - pin 19, relay - pins 9 and 10), and WELD ON (pin 20). The SOLENOID OUTPUT provides a *negative logic output* when referenced to the +24V DC source (pins 5 and 6). GENERAL ALARM, READY AND WELD ON signals provide a negative logic output when reference to 24V RTN (pins 21, 22, and 23).

These signals can be interfaced with a customer supplied device to monitor system status and trigger some action when the signals become active or inactive.

Pins 5 and 6 provide a +24V DC source (100mA maximum). Pins 21, 22, and 23 provide +24V DC return (common). The remaining pins are unused.

**Figure 3.6** IW/IW+ Input Output Signals

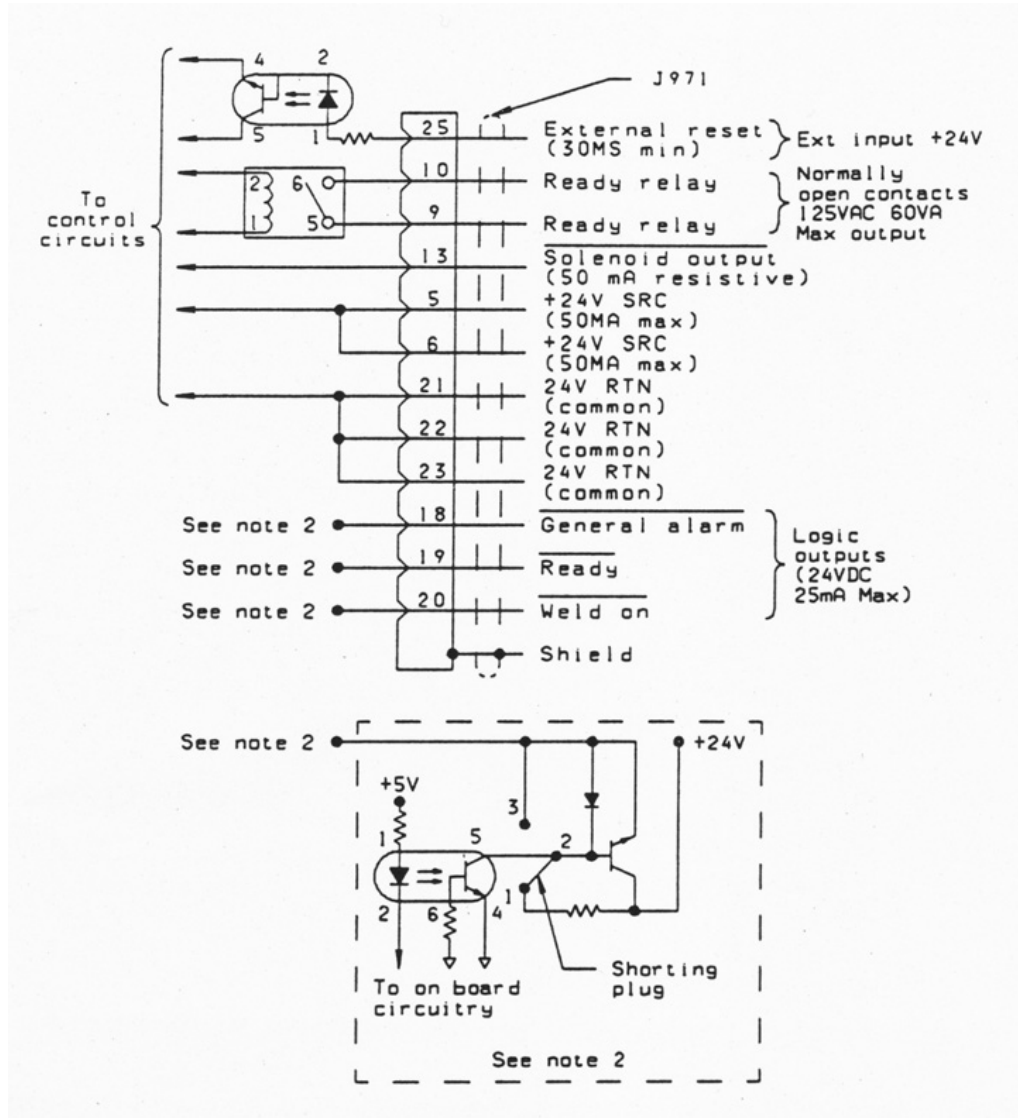

**Note 1:** You will note that the following pins are not connected: Pins 1, 2, 3, 4, 7, 8, 11, 12, 14, 15, 16, 17, and 24.

**Note 2:** Typical Circuitry for Pins 18, 19, and 20.

CAUTION	General Warning
	<p>Ensure all unused wires are properly isolated. Failure to do so may result in Power Supply Module or system failure.</p>

### 3.3.3 Pneumatic Requirements

The factory compressed air supply must be “clean (to a 5 micron level), dry and unlubricated” air with a regulated maximum pressure of 100 psig (690 kPa). Depending on your application, the welder requires between 35 to 100 psi to operate properly. The welder includes an in-line air filter. A quick-disconnect fitting is suggested. Use a lockout device on the air line if required.

CAUTION	General Warning
	<p>Synthetic air compressor lubricants containing Silicone or WD-40 will cause internal welder damage and failure due to the solvents contained within these types of lubricants.</p> <p>There should be no substitute for clean, dry air to run the welder. Use of other types of gas could lead to premature degradation of seals. Contact your Branson representative if you have any concerns.</p>

The pneumatic system is contained within the welder’s enclosure. Refer to [Figure 3.7](#).

The system consists of:

1. A primary solenoid valve,
2. An air cylinder,
3. A pressure regulator,
4. An air-pressure gauge.
5. Down speed control valve

The horn’s rate of descent (downspeed) is adjusted at the front of the actuator using the Downspeed control knob. The rate of ascent is fixed.

**Figure 3.7** Pneumatic Schematic

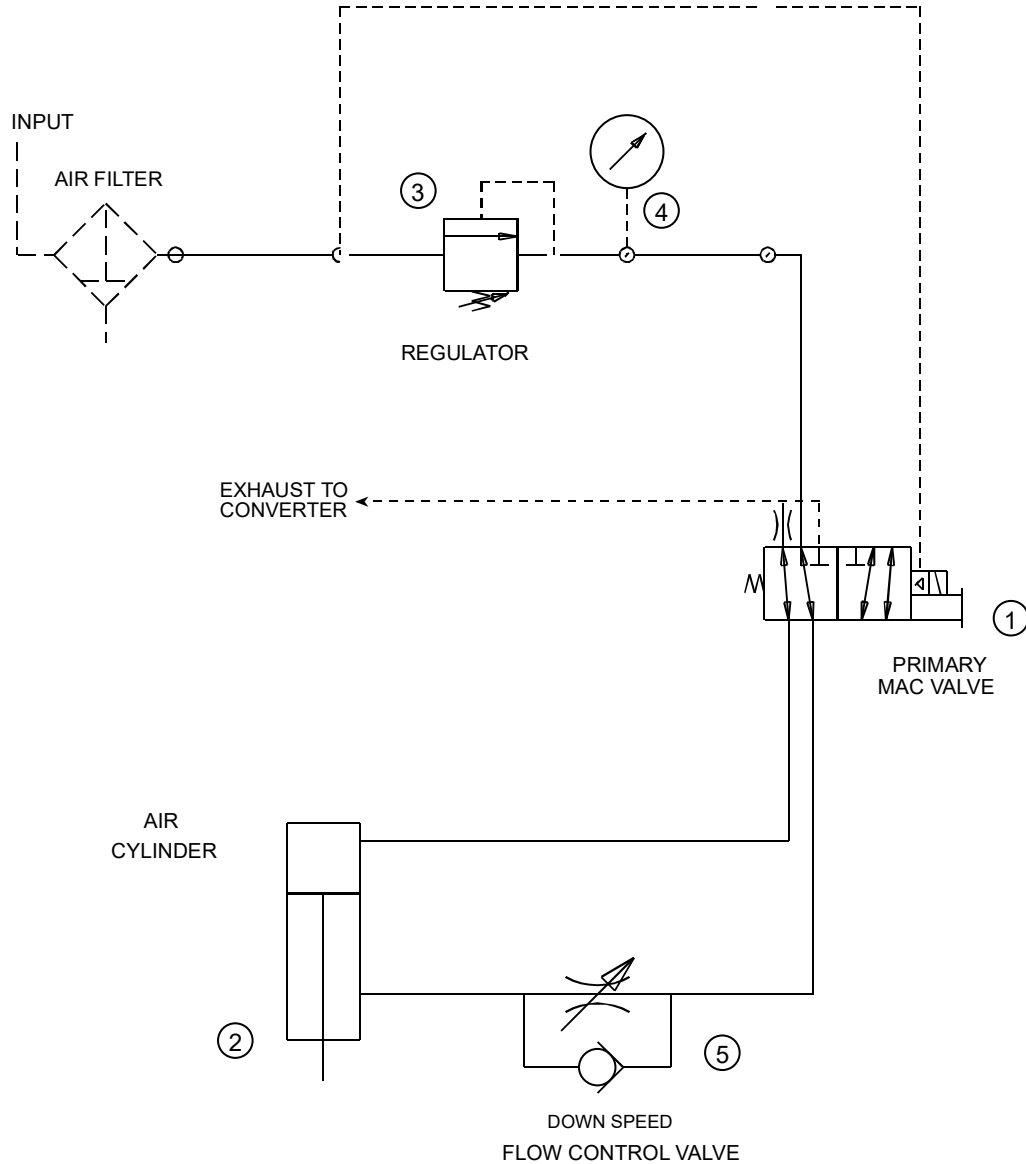

### 3.3.4 Pneumatic Circuit Descriptions

The 5-micron Air Filter at the input to the pneumatic system removes contaminants from the main air supply before the air enters the pneumatic system. The main air supply connects to the 2000 IW/IW+ pneumatic system via a 1/4 in. NPT fitting on the Air Filter. (For instructions on hooking up the main air supply, refer to your Operating Manual.)

<b>NOTICE</b>	
	<p>Make sure your main air supply provides compressed, dry, and unlubricated air.</p>

1. Solenoid Valve (SV) - directs the air flow of the pneumatic system as follows:
  - The Controller board energizes the SV with 24 VDC control signal
  - Air flows to the top of the Air Cylinder to lower the horn
  - At the end of Hold Time, the Controller board shuts off the 24 VDC to de-energize the SV
  - Air flows to the bottom of the Air Cylinder to raise the horn
2. Air Cylinder - lowers and raises the horn.
3. Pressure Regulator -provides working air pressure for the pneumatic system.
4. Pressure Gauge - indicates the current Pressure Regulator setting.
5. Down Speed Control Valve - controls the descent speed of the horn.

### 3.3.5 Pneumatic Sequence of Operations

The 2000 IW/IW+ pneumatic sequence follows:

1. When you press both START SWITCHES simultaneously, the Controller board energizes the SV with a 24 VDC control signal. The SV directs air flow to the top of the Air Cylinder.
2. The horn lowers to the workpiece. (The Down Speed Control Valve controls the horn DOWN SPEED by restricting air flow from bottom of the Air Cylinder).
3. The Controller board shuts off the 24 VDC to de-energize the SV. The SV directs air flow through the Down Speed Control Valve to the bottom of the Air Cylinder to raise the horn at a fixed speed.
4. When the horn reaches the home position, the Upper Limit Switch (ULS) sends a signal to the Controller module.

NOTICE	
	<p>If an electrical failure occurs, the SV de-energizes and the horn retracts to the home position.</p>

### 3.3.6 Pneumatic System Part Numbers

**Table 3.3** Pneumatic System Part Numbers

Component	Part Number
Air Filter	200-163-009
Air Cylinder*	
2.5 in. x 4 in.	100-246-576
3 in. x 4 in.	100-246-573
Connector, 1/4 in. NPT	200-029-590
Down Speed Control Valve	100-246-693
Pressure Gauge	100-246-691
Pressure Regulator	100-246-692

**Table 3.3** Pneumatic System Part Numbers

Component	Part Number
Solenoid Valve (SV), MAC, (blue)	100-246-694
Tubing, 1/4 in.	200-110-031

\* These Air Cylinder Part Numbers are for replacement. If you are converting to another cylinder size, contact Branson Product Support for the correct conversion kit.

### 3.3.7 Converters and Boosters

The 2000IW/IW+ uses the CJ 20 converter, EDP No. 101-135-059R.

**Figure 3.8** CJ 20 Converter

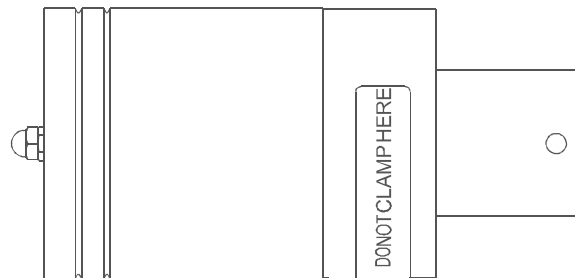

The 2000IW/IW+ uses the boosters listed in the following table

**Table 3.4** 2000IW/IW+ Boosters

Item	Description	Part Number
<b>Booster</b>	<b>3/8-24 Horn End Drill and Tap 1100 Watt Only</b>	
	Aluminum 1:0.6 (purple)	101-149-090
	Aluminum 1:1 (green)	101-149-093
	Aluminum 1:1.5 (gold)	101-149-092
	Aluminum 1:2 (silver)	101-149-094
	Titanium 1:2.5 (black)	101-149-091
<b>Booster</b>	<b>1/2-20 Horn End Drill and Tap All Models, Preferred</b>	
	Aluminum 1:0.6 (purple)	101-149-055
	Aluminum 1:1 (green)	101-149-051
	Aluminum 1:1.5 (gold)	101-149-052
	Aluminum 1:2 (silver)	101-149-053
	Titanium 1:0.6 (purple)	101-149-060
	Titanium 1:1 (green)	101-149-056
	Titanium 1:1.5 (gold)	101-149-057

**Table 3.4** 2000IW/IW+ Boosters

Item	Description	Part Number
	Titanium 1:2 (silver)	101-149-058
	Titanium 1:2.5 (black)	101-149-059
<b>Booster, Solid Mount</b>	<b>1/2 - 20 Input; 1/2 - 20 Output</b>	
	Titanium 1:2.5 (black)	101-149-099
	Titanium 2:1 (silver)	101-149-098
	Titanium 1:1.5 (gold)	101-149-097
	Titanium 1:1 (green)	101-149-096
	Titanium 1:0.6 (purple)	101-149-095

**Table 3.5** Other items used with the IW/IW+

Item	Description	Part Number
Mylar® Washers (for 20 kHz systems)	Kit, 10 each (1/2 in. or 3/8 in.)	100-063-357
	Kit, 150 each (1/2 in.)	100-063-471
	Kit, 150 each (3/8 in.)	100-063-472
Studs	1/2-20 x 1-1/4 (titanium horns and boosters)	100-098-370
	1/2-20 x 1-1/2 (aluminum horns and boosters)	100-098-123
	SCREW ALLEN 3/8-24 x 1	100-098-120



---

## **Chapter 4: Troubleshooting**

---

<b>4.1</b>	<b>General Troubleshooting Procedures</b> .....	<b>50</b>
<b>4.2</b>	<b>Troubleshooting Charts</b> .....	<b>51</b>
<b>4.3</b>	<b>Alarms</b> .....	<b>57</b>

## 4.1 General Troubleshooting Procedures

CAUTION	General Warning
	The Integrated Welder weighs 145 pounds. Handling, unpacking, and installation can require help or the use of lifting platforms or hoists.

If you have a problem operating your welder, take the following steps:

1. If error messages appear, refer to [4.3 Alarms](#) which provides definitions and solutions for each alarm.
2. Refer to the troubleshooting charts in [4.2 Troubleshooting Charts](#). These charts list common welder problems and possible solutions to these problems.
3. Refer to [Chapter 3: Schematics](#) and [Chapter 7: Master Parts List](#) to identify parts or assemblies needing checkout or replacement.
4. Refer to [Chapter 5: Assembly/Disassembly](#) for detailed instructions on removing and replacing faulty components.
5. If you need additional help, refer to [Chapter 1: Safety and Support](#) for information about returning equipment or acquiring further assistance.

NOTICE	
	2000 IW/IW+ Series Integrated Welders should be serviced only by qualified technicians using Branson-approved test and repair equipment, repair procedures, and replacement parts. Unauthorized attempts at repair or modification of the welder will void the warranty.

## 4.2 Troubleshooting Charts

### 4.2.1 Fuses/Circuit Breaker

NOTICE	
	Do not reset a plant or welder circuit breaker more than once without further troubleshooting.

**Table 4.1** Fuse/Circuit Breaker Troubleshooting

Problem	Cause/Solution	Refer to
Plant fuse fails or plant circuit breaker trips when plugging the welder into an electrical outlet.	Inspect line cord assembly; replace if faulty.	N/A
Plant fuse fails or plant circuit breaker trips during weld cycle.	Check rating and load of plant electrical system.	N/A
Welder circuit breaker (CB1) trips.	Check fan motor; replace if faulty.	<a href="#">Chapter 5: Assembly/Disassembly</a>

### 4.2.2 Fans

NOTICE	
	Do not reset a plant or welder circuit breaker more than once without further troubleshooting.

**Table 4.2** Fan Troubleshooting

Problem	Cause / Solution	Refer to
Fan does not work; power On/Off indicator light is On.	Check fan motor; replace if faulty.	<a href="#">Chapter 5: Assembly/Disassembly</a> Check DC Supply
	Check line voltage.	N/A

**Table 4.2** Fan Troubleshooting

Problem	Cause / Solution	Refer to
Fan does not work; power On/Off indicator does not light when On/Off switch is On.	Make sure welder plugged into main power.	N/A
	Inspect line cord assembly; replace if faulty.	N/A
	Inspect Circuit Breaker (CB1); replace if faulty.	<a href="#">Chapter 3: Schematics</a> <a href="#">Chapter 5: Assembly/Disassembly</a>
	Check line voltage	N/A

### 4.2.3 Ultrasonic Power

**Table 4.3** Ultrasonic Power Troubleshooting

Problem	Cause/Solution	Refer to
<p>No ultrasonic power to horn during weld cycle. The following conditions exist during the weld cycle:</p> <ul style="list-style-type: none"> <li>• No overload alarm (Error 18 IW, Error 19 IW+) displayed</li> <li>• POWER BARGRAPH displays brief or no indication;</li> <li>• welder completes weld cycle; and</li> <li>• welder tunes properly</li> </ul>	Failed or disconnected Output Control connection.	N/A

**Table 4.3** Ultrasonic Power Troubleshooting

Problem	Cause/Solution	Refer to
<p>No ultrasonic power to horn during weld cycle. The following conditions exist during the weld cycle:</p> <ul style="list-style-type: none"> <li>• Overload alarm (Error 18 IW, Error 19 IW+) displayed</li> <li>• POWER BARGRAPH displays brief or no indication;</li> <li>• welder completes weld cycle; and</li> <li>• welder tunes properly</li> </ul>	Check or reduce air pressure.	2000 IW/IW+ Operating Manual
	Check or reduce Dynamic Trigger setting.	
	Check booster; replace if faulty.	
	Consider using Pretrigger option.	
	Reduce the horn DOWN SPEED (adjust DOWN SPEED control setting)	
	Recondition Converter-Booster-Horn Stack mating surfaces.	<a href="#">6.1.1</a> <a href="#">Reconditioning the Stack (Converter, Booster and Horn)</a>
	Check horn; replace if faulty	2000 IW/IW+ Operating Manual
	Check converter; replace if faulty	
Output Control option set too low.	N/A	
<p>No ultrasonic power passed to horn during weld cycle. The following conditions exist during the weld cycle:</p> <ul style="list-style-type: none"> <li>• POWER BARGRAPH displays brief or no indication;</li> <li>• welder runs in TEST mode; and</li> <li>• welder tunes properly</li> </ul>	Main air supply too low. Check main air supply.	2000 IW/IW+ Operating Manual
	Adjust mechanical stop.	
	Dynamic Trigger setting too high; adjust setting.	
	Horn DOWN SPEED too low. Adjust DOWN SPEED control.	
	Pressure Gauge setting too low. Adjust setting.	
	Check Trigger Switch (TRS). Replace if faulty.	<a href="#">Chapter 3: Schematics</a> <a href="#">Chapter 5: Assembly/Disassembly</a>

**Table 4.3** Ultrasonic Power Troubleshooting

Problem	Cause/Solution	Refer to
No ultrasonic power generated when you press TEST; no overload alarm (Error 18 IW, Error 19 IW+) displayed.	Unplugged harness between Ultrasonic Power Supply module and Controller Board.	<a href="#">Chapter 3: Schematics</a>
	Converter is not installed.	
	Faulty or missing converter; replace or install converter.	2000 IW/IW+ Operating Manual
	Make sure all connections on Controller module are secure.	<a href="#">Chapter 3: Schematics</a> <a href="#">Chapter 5: Assembly/Disassembly</a>
Ultrasonic power delivered to horn; no indication appears on POWER BARGRAPH.	Check harness P22; repair if faulty.	<a href="#">Chapter 3: Schematics</a> ; <a href="#">Chapter 4: Troubleshooting</a> ; and <a href="#">Chapter 5: Assembly/Disassembly</a>
	Overload alarm (Error 18 IW, Error 19 IW+) appears on display: (a) during the weld cycle; or (b) when you press TEST.	Check Converter-Booster-Horn Stack mating surfaces for fretting corrosion.*
Tune the welder		
Check for loose or faulty horn or booster; tighten or replace as needed.		2000 IW/IW+ Operating Manual
Check for loose or faulty horn or booster setscrew (stud); tighten or replace as needed.		
Check converter; replace if faulty.		

\* Fretting corrosion refers to a black, crusty build-up, resulting from friction between metal parts, that appears on the Converter-Booster-Horn Stack mating surfaces. Refer to [6.1.1 Reconditioning the Stack \(Converter, Booster and Horn\)](#).

## 4.2.4 Weld Cycle

**Table 4.4** Weld Cycle Troubleshooting

Problem	Cause/Solution	Refer to
Welder completes weld cycle, tunes normally, but does not deliver full ultrasonic power.	Check line voltage	Plant manager
	Adjust Trigger Switch Setting (TRS).	2000 IW/IW+ Operating Manual
	Verify weld parameters.	
	Horn operates at the end of the Air Cylinder stroke; adjust horn travel.	
	Adjust mechanical stop	
	Unsuitable horn or booster selection.	Local Branson Representative
	Plastic part material varies.	Branson Applications Lab
	Mold release lubricant in weld area.	N/A
	Unsuitable joint design.	Branson Applications Lab
	Unsuitable or misaligned part fixture.	N/A
	Check Pressure Regulator; replace if faulty.	<a href="#">Chapter 3: Schematics</a> <a href="#">Chapter 5: Assembly/Disassembly</a>
	Check Solenoid Valve for leakage; replace if faulty.	
	Check Air Cylinder and air line; replace if faulty.	
Welder is set in Collapse or Absolute distance mode, but Time setting does not allow for the collapse or absolute distances to be attained during a weld.	<a href="#">Chapter 6: Repair</a>	
When touching the welder, you get a slight electric shock.	Inspect line cord assembly; repair or replace as needed.	<a href="#">Chapter 3: Schematics</a> <a href="#">Chapter 7: Master Parts List</a>
	Verify connection of all ground wires.	<a href="#">Chapter 3: Schematics</a>

**Table 4.4** Weld Cycle Troubleshooting

Problem	Cause/Solution	Refer to
<p>Excessively warm Converter-Booster-Horn Stack with the following conditions:</p> <ul style="list-style-type: none"> <li>occasional overload alarms;</li> <li>in TEST mode POWER BARGRAPH indication higher than normal (IW/IW+ 1100W above 20, IW/IW+ 2200W above 15)</li> </ul>	<p>Check Converter-Booster-Horn Stack mating surfaces for fretting corrosion. *</p>	<p><a href="#">Chapter 6: Repair</a></p>
	<p>If your welder is subject to high duty cycles, you may need to increase horn cooling.</p>	<p>Local Branson Representative</p>
<p>Welder does not cycle when you press both START SWITCHES or activate external START switches.</p> <p><b>NOTICE</b>  <a href="#">4.3 Alarms</a> contains a table that lists descriptions and solutions to alarms.</p>	<p>EMERGENCY STOP (E-STOP) switch open. Close E-STOP switch.</p>	<p><a href="#">Chapter 3: Schematics</a></p>
	<p>Make sure you press both START SWITCHES simultaneously.</p>	<p>N/A</p>
	<p>Adjust the PRESSURE REGULATOR.</p>	<p>2000 IW/IW+ Operating Manual</p>
	<p>Check the Solenoid Valve; replace if faulty.</p>	<p><a href="#">Chapter 3: Schematics</a>  <a href="#">Chapter 5: Assembly/Disassembly</a></p>
	<p>Verify that the DOWN SPEED control valve is open.</p>	<p><a href="#">Chapter 3: Schematics</a></p>
	<p>Inspect air tubing for obstructions.</p>	<p><a href="#">Chapter 4: Troubleshooting</a>  <a href="#">Chapter 5: Assembly/Disassembly</a></p>
	<p>Check START SWITCHES start circuit; repair or replace faulty components.</p>	<p><a href="#">Chapter 3: Schematics</a>  <a href="#">Chapter 5: Assembly/Disassembly</a>                      2000 IW/IW+ Operator Manual</p>

## 4.3 Alarms

Alarms occur when the welder does not successfully complete a weld cycle. Conditions that cause alarms include overloads or hardware failures. In addition, alarms display when you press a parameter selection switch while an active alarm exists.

When an alarm occurs, the Numeric Display on the front panel displays an alarm code. An alarm code takes the form Error xx - where Error represents an alarm, and xx is the number of the alarm code.

Alarms are classified into four types of alarms: *Latching*, *Non-Latching*, *Non-Resettable*, and *Latchable*. Actions you can take to reset the welder depend on the type of alarm. The following lists the four types of alarms:

**Table 4.5** Alarm Types and Action

Alarm Type	Action Required
Latching	Press RESET before the next weld cycle can start.
Non-Latching	Correct the condition that caused the alarm. Once you correct the condition, the alarm code disappears and the welder is ready to run a weld cycle.
Non-Resettable	Correct the condition that caused the alarm. (A Non-Resettable alarm usually occurs due to a hardware failure.) Clear the alarm by powering the welder OFF, then powering the welder ON. If the alarm still appears, continue troubleshooting.
Latchable	Set the Alarm Latch Enable DIP switch to make a Latchable alarm Latching or Non-Latching. To make an alarm Non-Latching, set the DIP switch to OFF. For information on setting the Alarm Latch Enable DIP switch, refer to your 2000 IW/IW+ Series Integrated Welders Operating Manual.

### 4.3.1 Alarm Codes and Error Messages

The following Table contains descriptions and common causes and solutions for each alarm code generated by the IW or IW+ welder.

**Table 4.6** Error Codes

Error Code	IW	IW+	Description	Cause/Solution
Error 01	x	x	ULS Ready Error <i>Latchable</i> - The ULS input was not active while the welder was in the READY state. Activated at the end of an aborted cycle.	<ul style="list-style-type: none"> <li>Adjust ULS</li> <li>Check UL; replace if faulty</li> <li>Check Controller Module; replace if faulty</li> </ul>
Error 03	x	x	TRS Ready Error <i>Latchable</i> - The TRS input was active while the welder was in the READY state, or trying to enter the READY state.	<ul style="list-style-type: none"> <li>Adjust TRS</li> <li>Check TRS. Clean if dirty; replace if faulty</li> <li>Check Controller Board; replace if faulty</li> </ul>

**Table 4.6** Error Codes

Error Code	IW	IW+	Description	Cause/Solution
Error 04	x		LLS Ready <i>Latchable</i> - The LLS input was active while the welder was in the READY state.	<ul style="list-style-type: none"> <li>• Adjust LLS</li> <li>• Check LLS; replace if faulty</li> <li>• Check Controller; replace if faulty</li> </ul>
Error 05	x		SV Ready <i>Non-Resettable</i> - The SV drive input indicates that the output was active while the welder was in the READY state. This often indicates a blown fuse.	<ul style="list-style-type: none"> <li>• Solenoid Valve shorted; repair or replace SV</li> <li>• Eliminate any electrical noise that may interfere with welder circuitry</li> <li>• Check Controller Module; replace if faulty</li> </ul>
Error 06	x	x	ULS Enter Non-Latching - The ULS input did not become inactive within 4 sec. of SV drive activation and remained active until weld time began.	<ul style="list-style-type: none"> <li>• Check Solenoid Valve; repair or replace if faulty</li> <li>• Adjust mechanical stop</li> <li>• Check Air Cylinder</li> <li>• Main air supply too low; check main air supply</li> <li>• Down Speed too low; adjust down speed</li> <li>• Air pressure too low; adjust the Pressure Regulator</li> <li>• Check ULS. Clean if dirty; replace if faulty</li> <li>• Check Controller Module; replace if faulty</li> </ul>
Error 08	x	x	TRS Enter Error <i>Non-Latching</i> - The TRS input did not become active within 4 sec. of ULS becoming inactive.	<ul style="list-style-type: none"> <li>• Main air supply too low; check main air supply</li> <li>• Trigger Pressure setting too high; adjust setting</li> <li>• Down Speed too low; adjust Down Speed</li> <li>• Air pressure too low; adjust the Pressure Regulator</li> <li>• Check TRS; replace if faulty</li> <li>• Check Controller Module; replace if faulty</li> </ul>
Error 09	x		LLS Enter <i>Non-Latching</i> - The LLS input became active before weld timing began.	<ul style="list-style-type: none"> <li>• Adjust LLS</li> <li>• Check LLS; replace if faulty</li> <li>• Check Controller Module; replace if faulty</li> </ul>

**Table 4.6** Error Codes

Error Code	IW	IW+	Description	Cause/Solution
Error 10	x		PBS Enter <i>Non-Latching</i> - The START SWITCHES were not pressed within 100 to 200 ms of each other, or the START SWITCH inputs were lost before the TRS input became active and before weld timing began.	<ul style="list-style-type: none"> <li>Make sure to press both START SWITCHES simultaneously (within 100 to 200 ms of each other)</li> <li>Make sure to keep pressing both START SWITCHES or remote START switch until trigger occurs</li> <li>Check Controller Module; replace if faulty</li> </ul>
Error 11	x	x	ULS Exit <i>Non-Latching</i> - The ULS input did not become active within 4 seconds of SV drive deactivation (time after TRS has become inactive)	<ul style="list-style-type: none"> <li>Adjust ULS</li> <li>Check ULS; replace if faulty</li> <li>Check Controller Module; replace if faulty</li> </ul>
Error 13	x	x	TRS Exit Error <i>Non-Latching</i> - The TRS input did not become inactive within 4 seconds of SV drive deactivation (allowed time)	<ul style="list-style-type: none"> <li>Check Solenoid Valve; repair or replace if faulty</li> <li>Check the TRS. Clean if dirty; replace if faulty</li> <li>Check Controller Module; replace if faulty</li> </ul>
Error 14	x	x	PBS Exit Error <i>Non-Latching</i> - The PB inputs did not become inactive within 4 seconds of SV drive deactivation, or were still active after power-up or after E-STOP inputs have been deactivated (within 4 seconds of the ULS becoming inactive)	<ul style="list-style-type: none"> <li>Check Controller Module; replace if faulty</li> <li>Check START SWITCHES or remote START switches</li> </ul>
Error 15	x	x	TRS Weld Error <i>Latchable</i> - The TRS input became inactive during weld or hold timing (before the ULS became inactive).	<ul style="list-style-type: none"> <li>Check workpiece, fixture, and welder setup (refer to your 2000 IW/IW+ Operating manual)</li> <li>Stroke length too short (stroke must exceed approx. 1/4 in)</li> <li>Check Controller Module; replace if faulty</li> </ul>
Error 16	x		ULS Lost waiting for TRS <i>Latchable</i> - After the ULS input became inactive, the ULS input became active again before the TRS input became active.	<ul style="list-style-type: none"> <li>Main air supply too low;</li> <li>check main air supply</li> <li>Start Switches released before TRS</li> </ul>

**Table 4.6** Error Codes

Error Code	IW	IW+	Description	Cause/Solution
Error 17	x		LLS Function <i>Latchable</i> - The LLS input met the conditions for an LLS error as defined by the LLS control DIP switches.	<ul style="list-style-type: none"> <li>Check DIP switch settings (refer to your 2000IW/IW+ Operating Manual)</li> </ul>
Error 18	x		Power Supply Startup Overload <i>Latchable</i> - The Power Supply overloaded within the first 50 ms of operation.	<ul style="list-style-type: none"> <li>Refer to <a href="#">4.2.3 Ultrasonic Power</a></li> </ul>
Error 19	x	x	Power Supply Overload Error <i>Latchable</i> - The AUPS indicated a power supply overload within the first 60 ms of operation.	<ul style="list-style-type: none"> <li>Test Ultrasonic Power Supply module; replace if faulty</li> <li>Test converter-Booster-Horn Stack</li> <li>Tune the welder</li> </ul>
Error 20	x		NOVRAM Data <i>Latchable</i> - The data read from non-volatile memory did not pass a data integrity check. If the power supply cannot read the parameter settings stored in NOVRAM at power-up, the factory-set settings are used.	<ul style="list-style-type: none"> <li>Refer to <a href="#">4.2.3 Ultrasonic Power</a></li> </ul>
Error 21	x	x	SV Active Error <i>Non-Resettable</i> - The SV drive output did not meet the requirements for activating the SV. This error cannot be cleared by RESET, or by the external RESET input.	<ul style="list-style-type: none"> <li>Check SV; repair or replace if faulty</li> <li>Check Controller Module; replace if faulty</li> </ul>

**WARNING**

Do not repair, replace or modify any part of the SV Safety Circuit.

Error 25		x	SV Deactive Error <i>Non-Resettable</i> - The SV drive output did not meet the requirements for deactivating the solenoid valve. This error cannot be cleared by RESET, or by the external RESET input.	<ul style="list-style-type: none"> <li>Check SV; repair or replace if faulty</li> <li>Check Controller Module; replace if faulty</li> </ul>
----------	--	---	---	---

**WARNING**

Do not repair, replace or modify any part of the SV Safety Circuit.

**Table 4.6** Error Codes

Error Code	IW	IW+	Description	Cause/Solution
Error 26		x	START SWITCH 2 Lost <i>Non-Latching</i> - START SWITCH 2 was lost before the trigger became active.	<ul style="list-style-type: none"> <li>Check START SWITCHES and remote START switches</li> <li>Make sure to keep pressing both START SWITCHES until triggering occurs</li> <li>Check Controller Module; replace if faulty</li> </ul>
Error 27		x	SV Safety Error <i>Non-Resettable</i> - SV drive safety circuit is not working. This error cannot be cleared by RESET, or by the external RESET input.	<ul style="list-style-type: none"> <li>Check Controller Module; replace if faulty</li> </ul>

**WARNING**

Do not replace, repair or modify any part of the SV Safety Circuit.

Error 28		x	START SWITCH 2 Stagger Error <i>Non-Latching</i> - START SWITCH 2 was not pressed within 200 ms after START SWITCH 1 was pressed.	<ul style="list-style-type: none"> <li>Press both START SWITCHES simultaneously</li> </ul>
Error 29		x	START SWITCH 1 Stagger Error <i>Non-Latching</i> - START SWITCH 1 was not pressed within 200 ms after START SWITCH 2 was pressed.	<ul style="list-style-type: none"> <li>Press both START SWITCHES simultaneously</li> </ul>
Error 30		x	Time Limit Error <i>Latchable</i> - Minus time limit not reached.	<ul style="list-style-type: none"> <li>Change -Limit value</li> <li>Contact Branson Applications Lab</li> </ul>
Error 31		x	Collapse Limit Error <i>Latchable</i> - Plus collapse limit exceeded or minus collapse limit not reached.	<ul style="list-style-type: none"> <li>Increase Collapse window</li> <li>Contact Branson Applications Lab</li> </ul>
Error 32		x	Absolute Limit Error <i>Latchable</i> - Plus absolute limit exceeded or minus absolute limit not reached, or weld aborted because of overload.	<ul style="list-style-type: none"> <li>Increase Absolute window</li> <li>Contact Branson Applications Lab</li> </ul>
Error 33		x	Time Limit Setup Error <i>Latchable</i> - Value for minus limit greater than value for plus limit, or minus limit greater than nominal value, or plus limit less than the nominal value.	<ul style="list-style-type: none"> <li>Check -Limit and +Limit values</li> <li>Check Weld Time</li> <li>Contact Branson Application Lab or Local Branson representative</li> </ul>

**Table 4.6** Error Codes

Error Code	IW	IW+	Description	Cause/Solution
Error 34		x	Collapse Limited Setup Error Latchable - Value for minus limit greater than value for plus limit, or plus limit less than nominal value.	<ul style="list-style-type: none"> <li>• Check -Limit and +Limit values</li> <li>• Check Collapse settings</li> <li>• Contact Branson Applications Lab or local Branson representative</li> </ul>
Error 35		x	Absolute Limit Setup Error Latchable - Value for minus limit greater than value for plus limit, or plus limit less than nominal value.	<ul style="list-style-type: none"> <li>• Check -Limit and +Limit values</li> <li>• Check Absolute setting</li> <li>• Contact Branson Applications Lab</li> </ul>
Error 37		x	TRS Lost Error <i>Latchable</i> - TRS was lost during weld time, hold time, or horn down.	<ul style="list-style-type: none"> <li>• Adjust Trigger pressure setting</li> <li>• Check TRS; replace if faulty</li> <li>• Check Controller Board; replace if faulty</li> <li>• Consider selecting TRS=EDGE instead of TRS=LEVEL (refer to the 2000 IW/IW+ Operating Manual)</li> </ul>
Error 38		x	ULS Weld Error <i>Latchable</i> - ULS was active during weld time or during hold time.	<ul style="list-style-type: none"> <li>• Check ULS; clean if dirty, replace if faulty</li> <li>• Check Controller Module; replace if faulty</li> </ul>
Error 39		x	ULS Active Error <i>Latchable</i> - ULS became active while waiting for the TRS after the ULS was already inactive.	<ul style="list-style-type: none"> <li>• Check ULS; clean if dirty, replace if faulty</li> <li>• Check Controller Module; replace if faulty</li> <li>• Check air pressure</li> <li>• Check SV; repair or replace if faulty</li> </ul>
Error 40		x	START SWITCH 1 Lost Error <i>Non-Latching</i> - START SWITCH 1 was lost before the trigger became active.	<ul style="list-style-type: none"> <li>• Check START SWITCHES or remote START switches</li> <li>• Make sure to keep pressing both START SWITCHES or remote START switches until triggering occurs</li> <li>• Check Controller Module; replace if faulty</li> </ul>

**For additional information about alarms, refer to the 2000 IW/IW+ Series Integrated Welder Operating Manual, EDP 1019568.**

---

## **Chapter 5: Assembly/Disassembly**

---

<b>5.1</b>	<b>Introduction . . . . .</b>	<b>64</b>
<b>5.2</b>	<b>Connecting and Disconnecting Air Lines . . . . .</b>	<b>66</b>
<b>5.3</b>	<b>Opening and Removing the Left Side Cover (EDP 100-032-338). . . . .</b>	<b>67</b>
<b>5.4</b>	<b>Main Assembly . . . . .</b>	<b>69</b>
<b>5.5</b>	<b>Nose Assembly . . . . .</b>	<b>84</b>

## 5.1 Introduction

Assembly/Disassembly provides instructions for removing and replacing serviceable 2000IW/IW+ components. This section groups serviceable components into three main assemblies: Main Assembly, Nose Assembly, and Main Support Assembly.

### 5.1.1 Main Assembly Components

- Ultrasonic Power Supply module
  - Control board
  - Power board
- Circuit Breaker/ On-Off switch (CB1)
- Line Board
- Box fan
- Solenoid Valve
- Column Clamps and Elevator Knob
- Power Supply, AC/DC Universal, 24V In, 5V Out
  - Fuse

### 5.1.2 Nose Assembly

- Control Module
  - Controller Board
  - Display board (IW EDP 100-242-1201R, IW+ EDP 100-242-1202R)
- Keypad (IW EDP 100-242-560, IW+ EDP 100-242-561)
- Pressure Regulator
- Pressure Gauge
- Down Speed Control Valve



### 5.1.3 Main Support Assembly

- Converter-Booster-Horn Stack
- Trigger Guard
- Air Cylinder
- Dynamic Trigger Mechanism
- RF Contact Block
- Carriage Return Spring
- Upper Limit /Switch (ULS)
- Trigger Switch (TRS)
- Linear Optical Encoder

Sections [5.2 Connecting and Disconnecting Air Lines](#) and [5.3 Opening and Removing the Left Side Cover \(EDP 100-032-338\)](#) contain preparatory instructions for tasks common to most repairs. When servicing the Control Module, refer to Section [5.5 Nose Assembly](#).

Before servicing the welder, review the following:

- Schematics and assembly drawings in [Chapter 3: Schematics](#) for supplemental information or for reference when removing components not covered in this section
- Assembly/Disassembly instructions contain Branson part numbers. If you cannot find a part number, refer to [Chapter 7: Master Parts List](#)
- When returning printed circuit boards, make sure to enclose them in an anti-static package. (You can use the same bag that enclosed the replacement board.)

WARNING	General Warning
	<p>Before servicing the welder, make sure to do the following:</p> <ol style="list-style-type: none"> <li>1. Turn off the welder and unplug main power.</li> <li>2. Turn air pressure to zero and disconnect your main air line connection. Failure to do this leaves the welder under potentially dangerous air pressure.</li> <li>3. Wait approximately 5 minutes after unplugging the welder before touching internal electrical components. Always measure the voltage to make sure that no charge remains. For location of circuit test points, refer to <a href="#">Chapter 3: Schematics</a>.</li> </ol>
CAUTION	General Warning
	<p>The welder contains static-sensitive printed circuit (PC) boards. Irreversible damage can occur to these boards if they receive a static discharge from tools or service personnel. To prevent damage to PC boards:</p> <ol style="list-style-type: none"> <li>1. Always service a PC board on a static-dissipative surface, while wearing a properly grounded wrist strap. Follow the manufacturer's instructions for proper use of this equipment.</li> <li>2. For ground points, refer to schematic diagrams in <a href="#">Chapter 3: Schematics</a>.</li> </ol>

## 5.2 Connecting and Disconnecting Air Lines

Figure 5.1 [Connecting and Disconnecting Air Lines](#) shows how to connect and disconnect the air line connection on the welder.

WARNING	General Warning
	<p>Before servicing the welder, make sure to do the following:</p> <ol style="list-style-type: none"> <li>1. Turn off the welder and unplug main power.</li> <li>2. Turn air pressure to zero and disconnect your main air line connection. Failure to do this leaves the welder under potentially dangerous air pressure.</li> <li>3. Wait approximately 5 minutes after unplugging the welder before touching internal electrical components.</li> </ol>

**Figure 5.1** Connecting and Disconnecting Air Lines

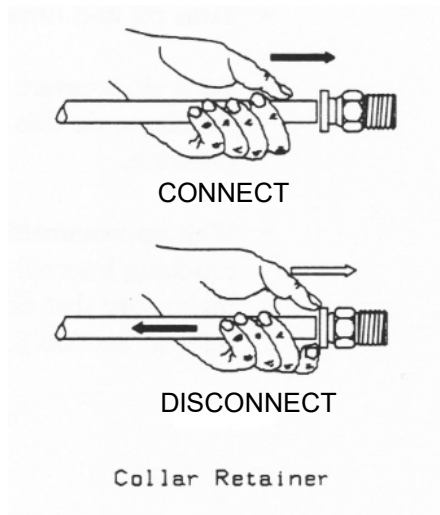

When replacing air lines, use 1/4 in. OD tubing. To avoid air leaks, make sure to cut the tubing ends squarely and cleanly.

CAUTION	General Warning
	<p>After connecting an air line, tug the line to make sure that it locks securely into the fitting.</p>

## 5.3 Opening and Removing the Left Side Cover (EDP 100-032-338)

WARNING	General Warning
	<p>Before servicing the welder, make sure to do the following:</p> <ol style="list-style-type: none"> <li>1. Turn off the welder and unplug main power.</li> <li>2. Turn air pressure to zero and disconnect your main air line connection. Failure to do this leaves the welder under potentially dangerous air pressure.</li> <li>3. Wait approximately 5 minutes after unplugging the welder before touching internal electrical components.</li> </ol>

**Figure 5.2** Opening the Left Side Cover

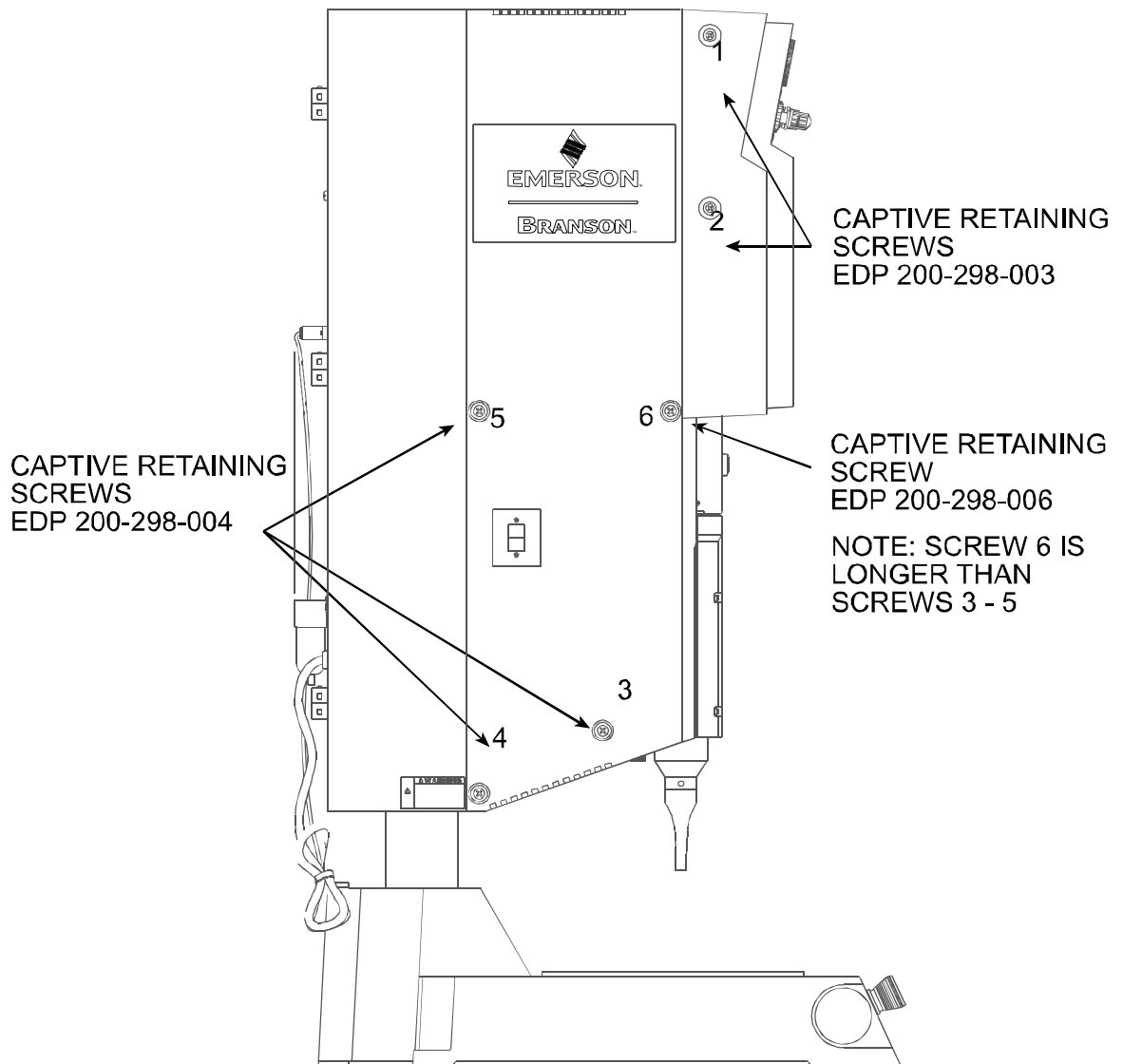

## 5.3.1 Opening and Removing the Left Side Cover

1. Turn off the welder and unplug main power.
2. Turn air pressure to zero; then disconnect the main air supply.

WARNING	General Warning
	<p>Turn air pressure to zero and disconnect the main air supply. Failure to do this leaves the welder under potentially dangerous air pressure.</p>

3. Loosen the two captive screws ([Figure 5.2 Opening the Left Side Cover](#), screws 1 & 2); then loosen the remaining captive screws ([Figure 5.2 Opening the Left Side Cover](#), screws 3 to 6).

NOTICE	
	<p>Removing the left side cover is optional - for most repairs you only need to open the cover.</p>

4. To remove the cover, hold the cover while tapping up on the bottom of the cover until the cover comes off the hinges.

## 5.3.2 Replacing the Left Side Cover

CAUTION	General Warning
	<p>Before closing the left side cover, make sure that all wires and tubing will not get crimped when you close the left side cover.</p>

**To close or replace the left side cover, reverse the instructions for removing.**

## 5.4 Main Assembly

This Section contains illustrations and instructions for removing and replacing the following welder components:

- Ultrasonic Power Supply module
  - Control board
  - Power board
- Power Supply, AC/DC Universal, 24V In, 5V Out
  - Fuse
- Box fan
- Circuit Breaker/ On-Off switch (CB1)
- Line Board
- Solenoid Valve
- Column Clamps and Elevator Knob

[Figure 5.3 Main Assembly Components \(Left Side View\)](#) contains a left side view of the Main Assembly components; [Figure 5.4 Main Assembly Components \(Right Side View\)](#) contains a right side view of the Main Assembly components. You can access all Main Assembly components by opening the left side cover.

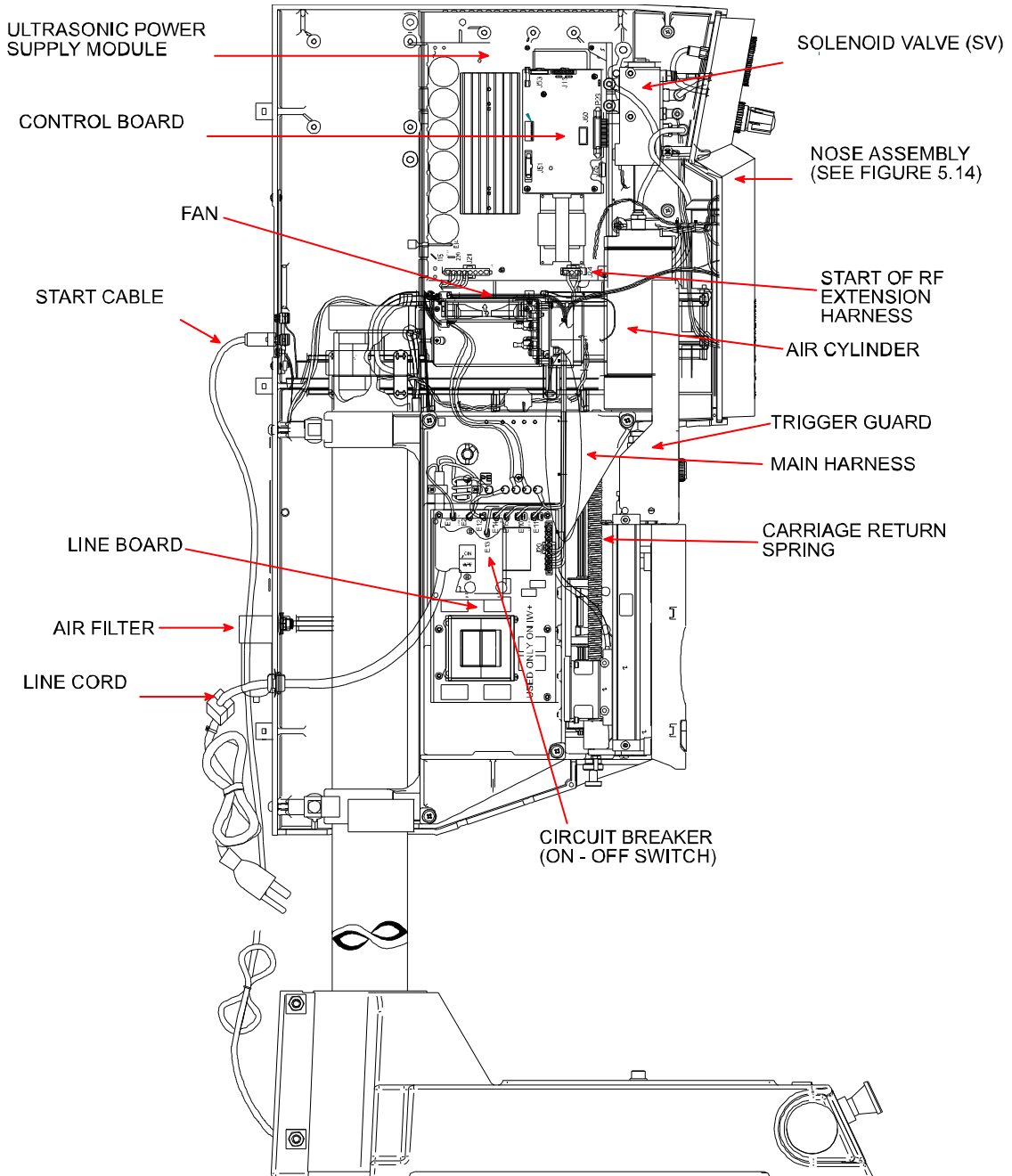

**Figure 5.3** Main Assembly Components (Left Side View)

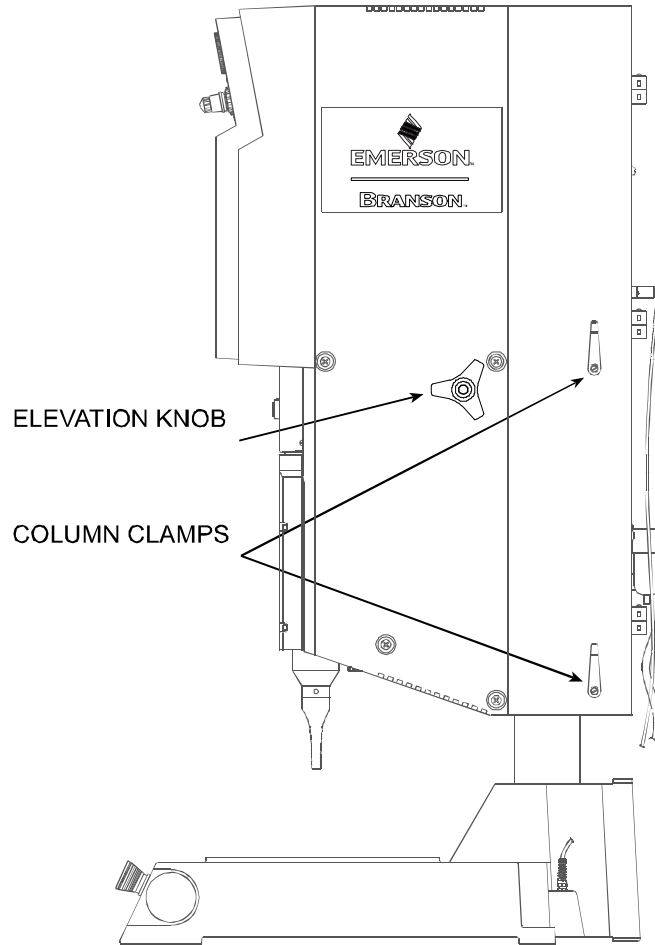

**Figure 5.4** Main Assembly Components (Right Side View)



## 5.4.1 Ultrasonic Power Supply Module

<b>WARNING</b>	<b>General Warning</b>
	<p>Before servicing the welder, make sure to do the following:</p> <ol style="list-style-type: none"> <li>1. Turn off the welder and unplug main power.</li> <li>2. Turn air pressure to zero and disconnect your main air line connection. Failure to do this leaves the welder under potentially dangerous air pressure.</li> <li>3. Wait approximately 5 minutes after unplugging the welder before touching internal electrical components.</li> </ol>
<b>CAUTION</b>	<b>General Warning</b>
	<p>Always service a PC board on a static-dissipative surface, while wearing a grounded wrist strap.</p>

CAUTION	General Warning
	<p>Take precautions not to leave any loose objects (such as screws, bolts, nuts, and so forth) in the welder. If you drop an object into the welder, <i>retrieve the object immediately.</i></p>

The Ultrasonic Power Supply Module consists of two components, the power board and control board. You cannot replace an individual board. If it has been determined that a portion of either board has failed, you must replace the entire Power Supply Module.

**Figure 5.5** Removing the Ultrasonic Power Supply Module

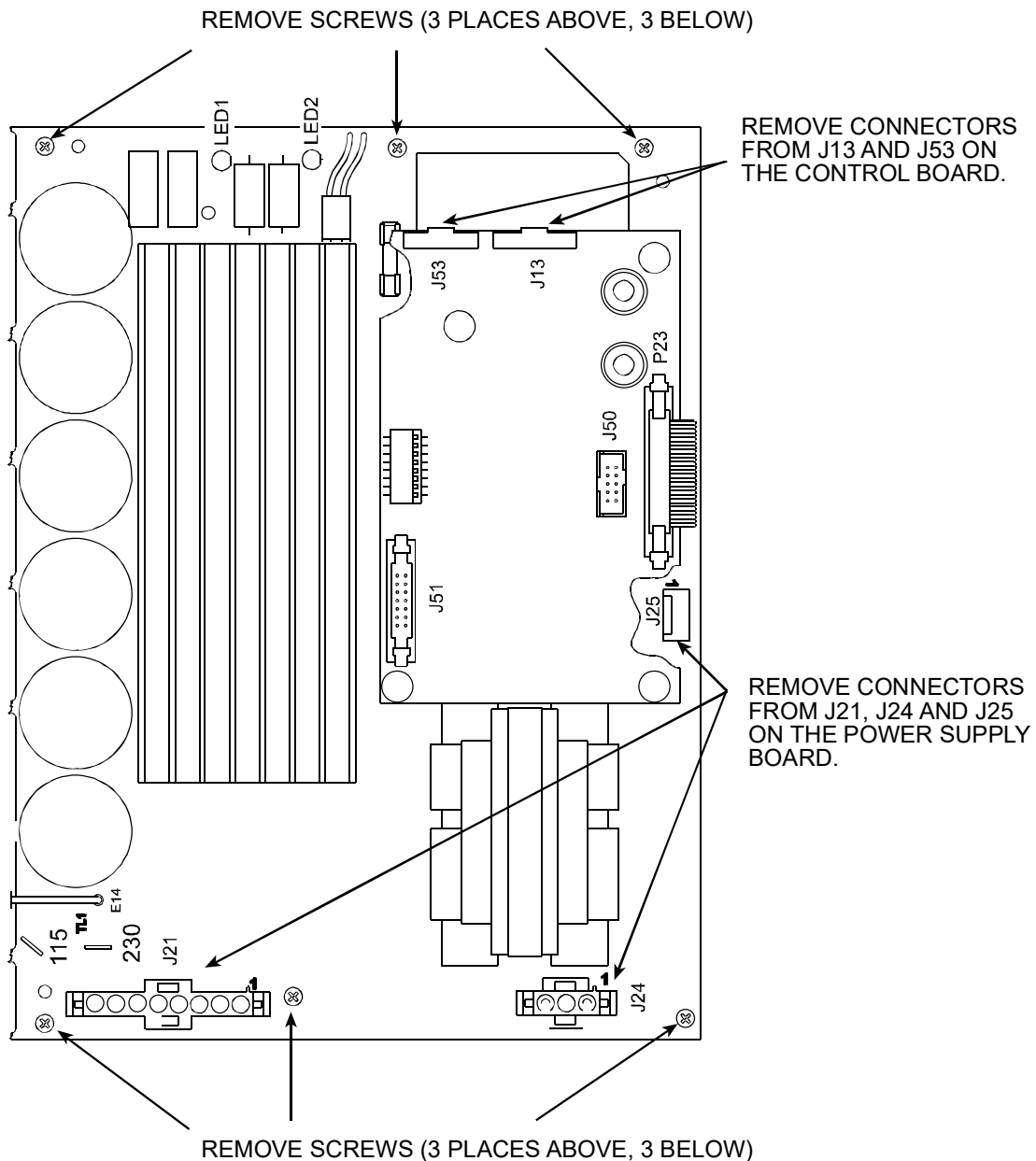

**5.4.1.1 Removing the Ultrasonic Power Supply Module**

1. Turn off the welder and unplug main power.
2. Turn air pressure to zero.

WARNING	General Warning
	<p>Turn air pressure to zero and disconnect the main air supply. Failure to do this leave the welder under potentially dangerous air pressure.</p>

3. Open the left side cover. See Section [5.3 Opening and Removing the Left Side Cover \(EDP 100-032-338\)](#).
4. Unplug the 3 connectors to the Control Board and 3 connectors to the Power Supply Board.
5. Remove the 6 screws that secure the Power Supply Module to the welder chassis, and remove module. The board is mounted on female/female standoffs that are secured from the rear through the chassis. Care should be taken not to unscrew the standoff from the chassis.

**5.4.1.2 Replacing the Ultrasonic Power Supply Module**

1. Ensure the six module support standoffs are secured to the chassis.
2. Return the module and secure with the six screws.
3. Reconnect the 6 connectors to the Control board and the Power Supply Board.
4. Connect the main air supply.
5. Close the left side cover. See Section [5.3 Opening and Removing the Left Side Cover \(EDP 100-032-338\)](#).
6. Tune the welder. See Section [6.1.3 Servicing the Air Filter \(Part No. 200-163-009\)](#).

## 5.4.2 Power Supply, AC/DC Universal, 24V In, 5V Out, and Box Fan

Figure 5.6 24/5 Volt Power Supply and Box Fan

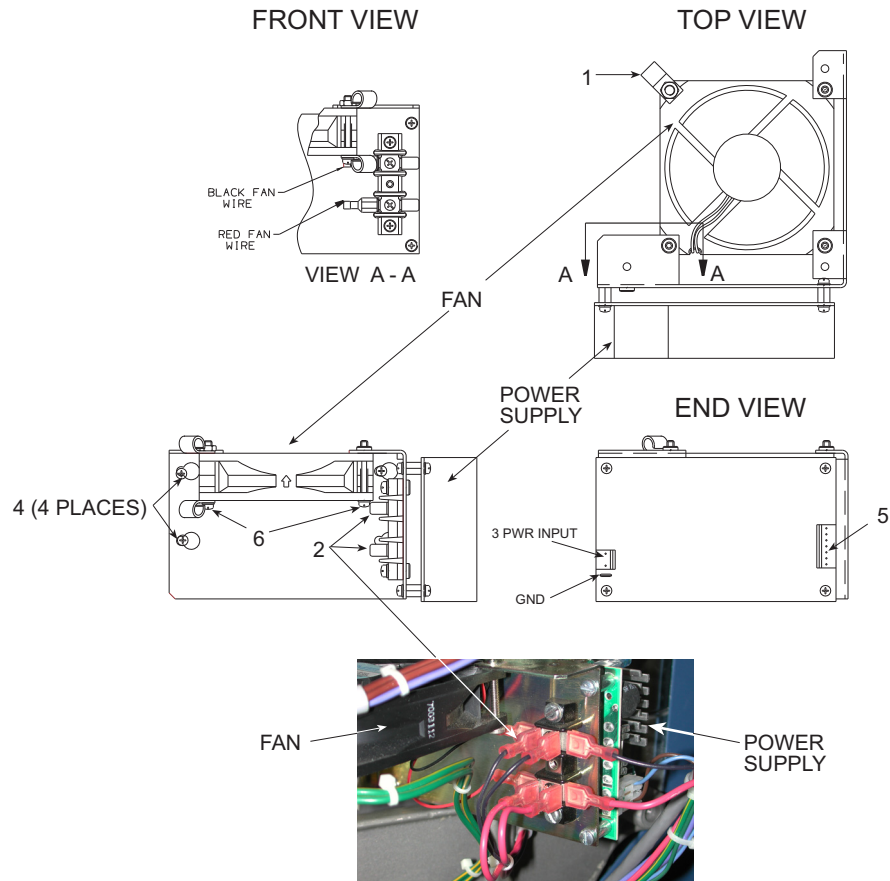

WARNING	General Warning
	<p>Before servicing the welder, make sure to do the following:</p> <ol style="list-style-type: none"> <li>1. Turn off the welder and unplug main power.</li> <li>2. Turn air pressure to zero and disconnect your main air line connection. Failure to do this leaves the welder under potentially dangerous air pressure.</li> <li>3. Wait approximately 5 minutes after unplugging the welder before touching internal electrical components.</li> </ol>

### 5.4.2.1 Remove 24/5 Volt Power Supply and Box Fan

The power supply and the fan are mounted on one common chassis, and are removed as a single unit. If it is necessary to repair or replace either of these units, it is necessary to first remove the unit, and then separate the fan from the power supply. Refer to [Figure 3.5 DC Power Module](#) and [Figure 5.6 24/5 Volt Power Supply and Box Fan](#).

NOTICE	
	<p>Do not totally remove screws. The screw holes are the keyhole type. This assembly is secured with 4 screws and only needs to be loosened to slide the assembly left, and pull toward you to allow the screw heads to pass through the keyholes. Total removal of the screws could cause the two bottom standoff spacers to fall into the welder.</p>

1. Turn off the welder and unplug main power.
2. Turn air pressure to zero.

WARNING	
	<p>Turn air pressure to zero and disconnect the main air supply. Failure to do this leave the welder under potentially dangerous air pressure.</p>

3. Open the left side cover. See Section [5.3 Opening and Removing the Left Side Cover \(EDP 100-032-338\)](#).
4. Snap out the harness routed through the clips (Item 1, [Figure 5.6 24/5 Volt Power Supply and Box Fan](#)) on the top left of the fan.
5. Remove and label the six spade lugs (Item 2, [Figure 5.6 24/5 Volt Power Supply and Box Fan](#)) on the left side of the power supply.
6. Remove and label the spade lug and 3 pin (24 V AC In) connector (Item 3, [Figure 5.6 24/5 Volt Power Supply and Box Fan](#)) on top of the power supply.
7. Loosen, but do not remove the four screws (Item 4, [Figure 5.6 24/5 Volt Power Supply and Box Fan](#)).
8. Slide the assembly to the left, and then pull gently toward you. There is still a six pin (5 V DC Out) connector (Item 5, [Figure 3.4 2000IW/IW+ Ultrasonic Power Module](#)) attached to the rear of the power supply. Remove it at this time.
9. If it is necessary to replace the fan, remove the three screws (Item 6, [Figure 5.6 24/5 Volt Power Supply and Box Fan](#)) and lock washers on the underside that attach the fan to the mounting bracket. Unplug the two spade lugs. Make certain that the red lug goes to the red terminal, and the black lug goes to the black terminal. Be certain to install the lock washers when re-installing the fan.
10. To replace the power supply, remove the four screws and lock washers that mount the board to the standoffs attached to the mounting bracket. Save the hardware for the replacement of the new or repaired unit.

### 5.4.2.2 Replacement of the 24/5 Volt Power Supply and Box Fan

Reverse the "Remove" instructions to replace the unit.

## 5.4.3 Circuit Breaker, On Off Switch

### 5.4.3.1 Remove and Replace Circuit Breaker, On Off Switch

Figure 5.7 Circuit Breaker, On Off Switch

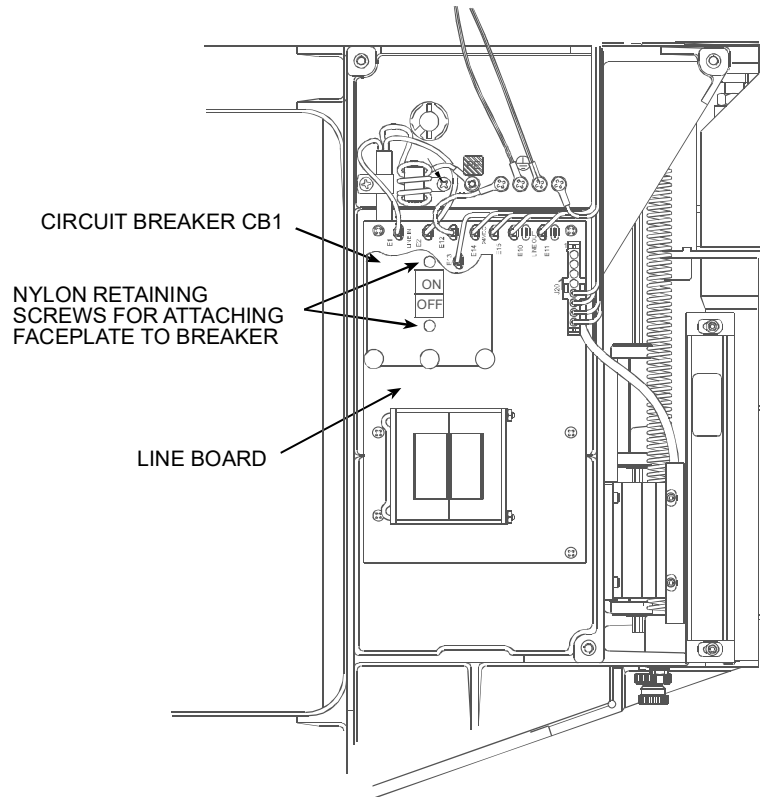

WARNING	General Warning
	<p>Before servicing the welder, make sure to do the following:</p> <ol style="list-style-type: none"> <li>1. Turn off the welder and unplug main power.</li> <li>2. Turn air pressure to zero and disconnect your main air line connection. Failure to do this leaves the welder under potentially dangerous air pressure.</li> <li>3. Wait approximately 5 minutes after unplugging the welder before touching internal electrical components.</li> </ol>

1. Turn off the welder and unplug main power.
2. Turn air pressure to zero, then disconnect main air supply.

WARNING	General Warning
	<p>Turn air pressure to zero and disconnect the main air supply. Failure to do this leave the welder under potentially dangerous air pressure.</p>

3. Open the left side cover. See Section [5.3 Opening and Removing the Left Side Cover \(EDP 100-032-338\)](#).
4. Firmly grasp the Breaker On/Off switch and remove by pulling it straight toward you.
5. Check the current rating on the side of the Circuit Breaker, then check the Table below to be certain the current rating matches your welder.

**Table 5.1** Circuit Breaker Part Number

<b>Breaker Current Rating</b>	<b>Power</b>	<b>Model</b>	<b>Line Voltage</b>	<b>Part Number</b>
8A	1100W	2000IW/IW+	200-240V	200-167-014R
17A	1100W	2000IW/IW+	100-117V	200-167-015R
17A	2200W	2000IW/IW+	200-240V	200-167-015R
25A	3300W	2000IW+	200-240V	1031631

6. Remove the two nylon screws that secure the switchplate to the breaker.
7. Replace the faulty breaker and re-attach the switchplate.
8. Press new breaker back onto the male tabs taking care to line it up before inserting.
9. Close and secure left door.
10. Connect the main air supply.
11. Plug in main power.
12. Turn unit power On.

## 5.4.4 Line Board

### 5.4.4.1 Removing the Line Board (EDP 100-242-546R)

**Figure 5.8** The Line Board

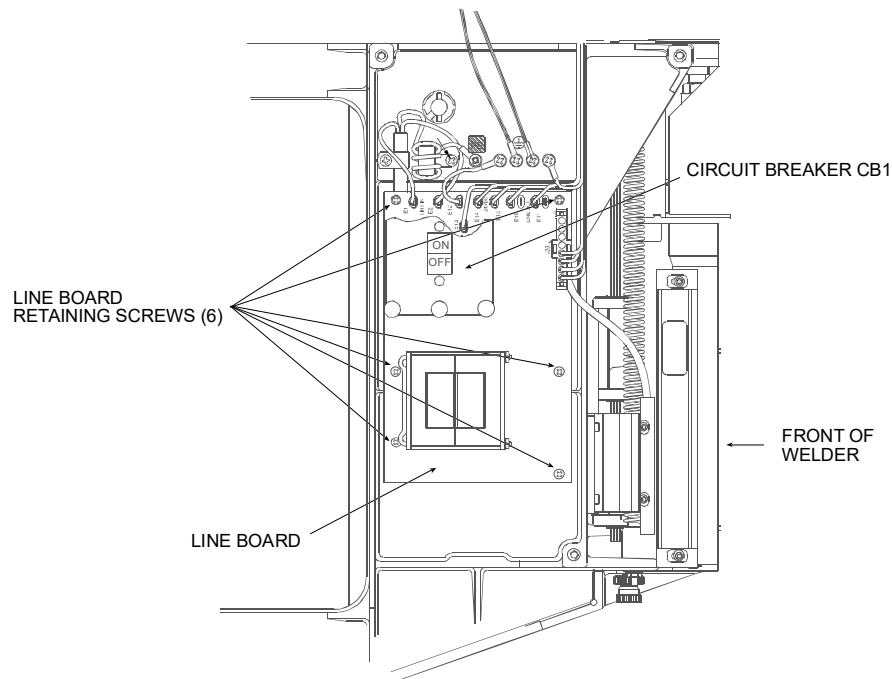

WARNING	General Warning
	<p>Before servicing the welder, make sure to do the following:</p> <ol style="list-style-type: none"> <li>1. Turn off the welder and unplug main power.</li> <li>2. Turn air pressure to zero and disconnect your main air line connection. Failure to do this leaves the welder under potentially dangerous air pressure.</li> <li>3. Wait approximately 5 minutes after unplugging the welder before touching internal electrical components.</li> </ol>

1. Turn off the welder and unplug main power.
2. Turn air pressure to zero, then disconnect main air supply.

WARNING	General Warning
	<p>Turn air pressure to zero and disconnect the main air supply. Failure to do this leave the welder under potentially dangerous air pressure.</p>

3. Open the left side cover. See Section [5.3 Opening and Removing the Left Side Cover \(EDP 100-032-338\)](#).

Label and unplug the following wires to the Line Board ([Figure 5.8 The Line Board](#))

- E1 (brown, from power input plug)
- E2 (blue, from power input plug)
- 10 (blue, to 24/5 V power supply)
- 11 (brown, to 24/5 V power supply)
- E12 (green and yellow ground wire, power input)
- E13 (green and yellow ground wire to Main Harness)
- 14 (red)
- 15 (black)
- P20 (to Power Supply Module)

<b>NOTICE</b>	
	<p>To unplug P20, squeeze the sides of the plug while pulling it out of J20.</p>

4. Unplug the Circuit Breaker ([Figure 5.7 Circuit Breaker, On Off Switch](#)).
5. While holding the Line Board in place, remove the six retaining screws and lock washers ([Figure 5.8 The Line Board](#)).
6. Remove the Line Board from the welder.

#### **5.4.4.2 Replacing the Line Board**

To replace the Line Board, reverse the instructions above.

#### **5.4.5 Solenoid Valve (SV)**

This welder uses one solenoid valve. The detail and location of the solenoid is shown in [Figure 5.9 Solenoid Valve \(SV\)](#).

**Figure 5.9** Solenoid Valve (SV)

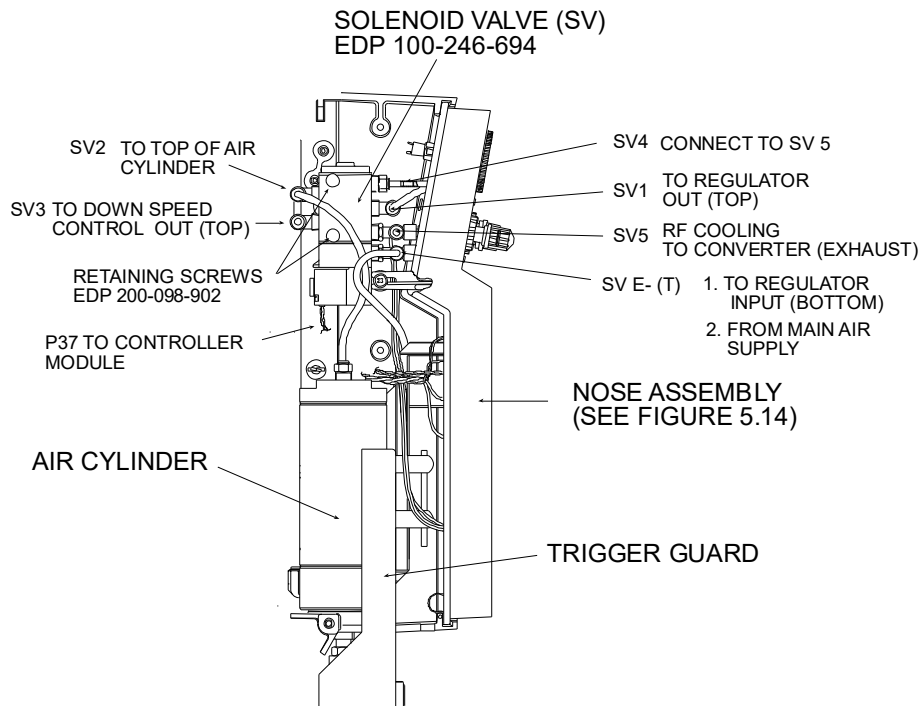

WARNING	General Warning
	<p>Before servicing the welder, make sure to do the following:</p> <ol style="list-style-type: none"> <li>1. Turn off the welder and unplug main power.</li> <li>2. Turn air pressure to zero and disconnect your main air line connection. Failure to do this leaves the welder under potentially dangerous air pressure.</li> <li>3. Wait approximately 5 minutes after unplugging the welder before touching internal electrical components.</li> </ol>

1. Turn off the welder and unplug main power.
2. Turn air pressure to zero, then disconnect main air supply.

WARNING	General Warning
	<p>Turn air pressure to zero and disconnect the main air supply. Failure to do this leave the welder under potentially dangerous air pressure.</p>

3. Open the left side cover. See Section [5.3 Opening and Removing the Left Side Cover \(EDP 100-032-338\)](#)
4. Label and remove all air lines to the SV ([Figure 5.9 Solenoid Valve \(SV\)](#)).
5. Unplug the SV connector (P37) from the Control Module.
6. Hold the SV in place while removing the two SV retaining screws.

7. Remove the SV from the welder.

#### 5.4.5.1 Replacing the Solenoid Valve

To replace the SV, reverse the instructions above.

#### 5.4.6 Column Clamps and Elevator Knob

WARNING	General Warning
	<p>Before servicing the welder, make sure to do the following:</p> <ol style="list-style-type: none"> <li>1. Turn off the welder and unplug main power.</li> <li>2. Turn air pressure to zero and disconnect your main air line connection. Failure to do this leaves the welder under potentially dangerous air pressure.</li> <li>3. Wait approximately 5 minutes after unplugging the welder before touching internal electrical components.</li> </ol>

**Figure 5.10** Column Clamps and Elevator Knob

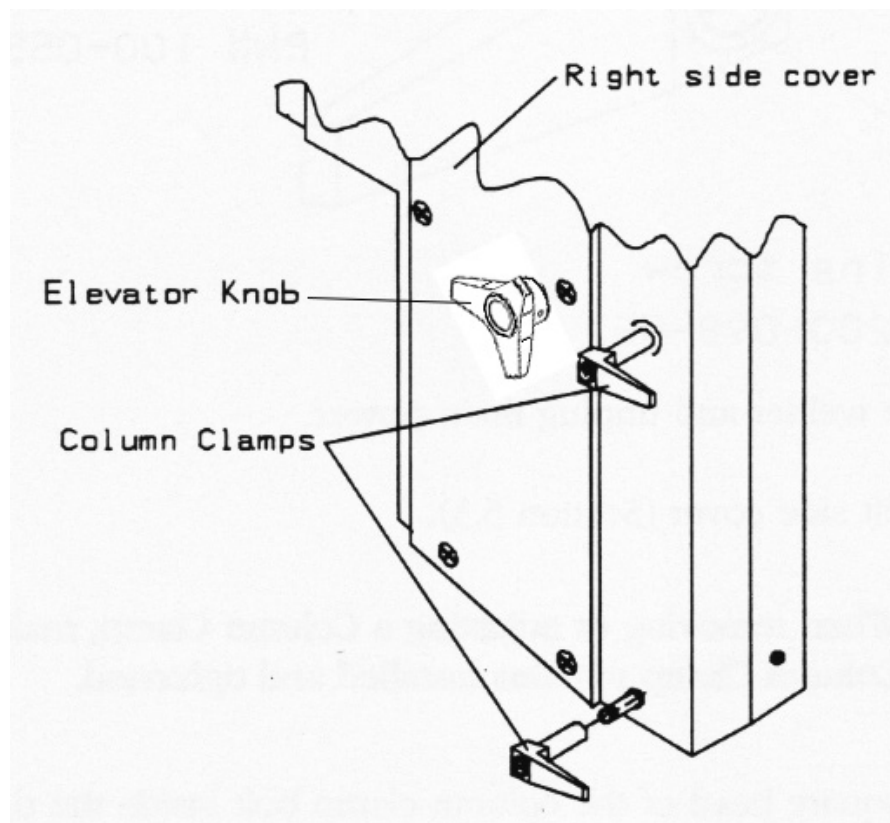

## 5.4.6.1 Removing a Column Clamp (EDP 100-055-028)

**Figure 5.11** Removing a Column Clamp

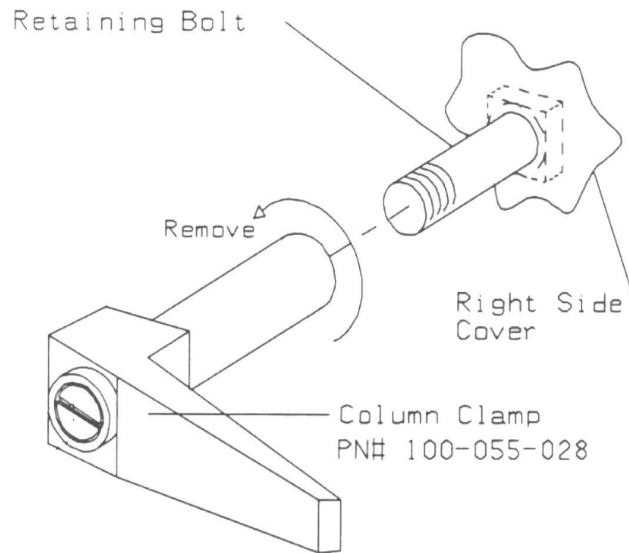

1. Turn off the welder and unplug main power.
2. Turn air pressure to zero, then disconnect main air supply.

WARNING	General Warning
	<p>Turn air pressure to zero and disconnect the main air supply. Failure to do this leave the welder under potentially dangerous air pressure.</p>

3. Open the left side cover. See Section [5.3 Opening and Removing the Left Side Cover \(EDP 100-032-338\)](#)
4. Locate the square head of the column clamp bolt ([Figure 5.11 Removing a Column Clamp](#)).
5. Hold the bolt and turn the Column Clamp counterclockwise until you can pull the clamp off the bolt ([Figure 5.11 Removing a Column Clamp](#)).

## 5.4.6.2 Replacing a Column Clamp

To replace a Column Clamp, reverse the instructions above.

## 5.4.6.3 Removing the Elevator Knob (EDP 200-064-015)

WARNING	General Warning
	<p>Before servicing the welder, make sure to do the following:</p> <ol style="list-style-type: none"> <li>1. Turn off the welder and unplug main power.</li> <li>2. Turn air pressure to zero and disconnect your main air line connection. Failure to do this leaves the welder under potentially dangerous air pressure.</li> <li>3. Wait approximately 5 minutes after unplugging the welder before touching internal electrical components.</li> </ol>

**Figure 5.12** Removing the Elevator Knob

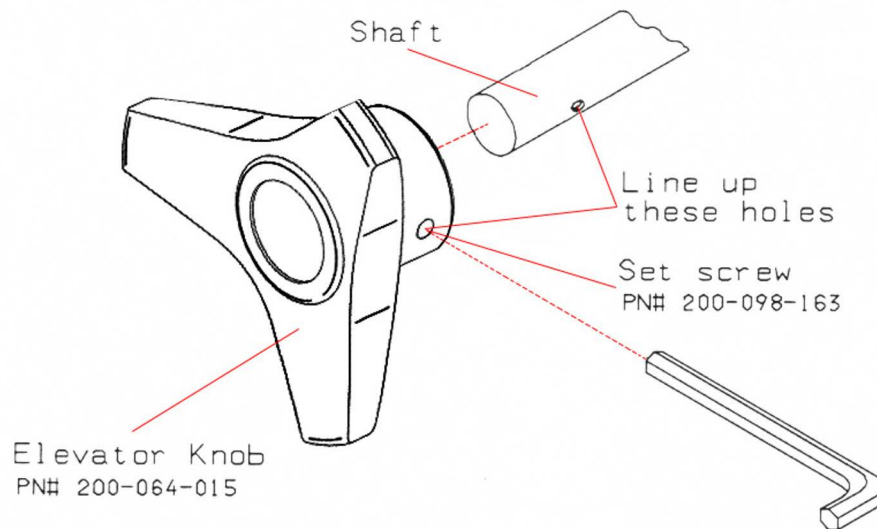

1. Turn off the welder and unplug main power.
2. Turn air pressure to zero, then disconnect main air supply.

WARNING	General Warning
	<p>Turn air pressure to zero and disconnect the main air supply. Failure to do this leave the welder under potentially dangerous air pressure.</p>

3. Open the left side cover. See Section [5.3 Opening and Removing the Left Side Cover \(EDP 100-032-338\)](#)
4. Use a 1/8 in. Allen wrench to loosen the set screw until you can pull the Elevator Knob off the shaft ([Figure 5.12 Removing the Elevator Knob](#)).

## 5.4.6.4 Replacing the Elevator Knob

To replace the Elevator Knob, reverse the instructions above.

## 5.5 Nose Assembly

This section contains instructions for removing and replacing the following components.

- Control Module
  - Control Board
  - Display Board
- Keypad
- Pressure Regulator
- Pressure Gauge
- Down Speed Control Valve

**Figure 5.13** Nose Assembly Components and Connections

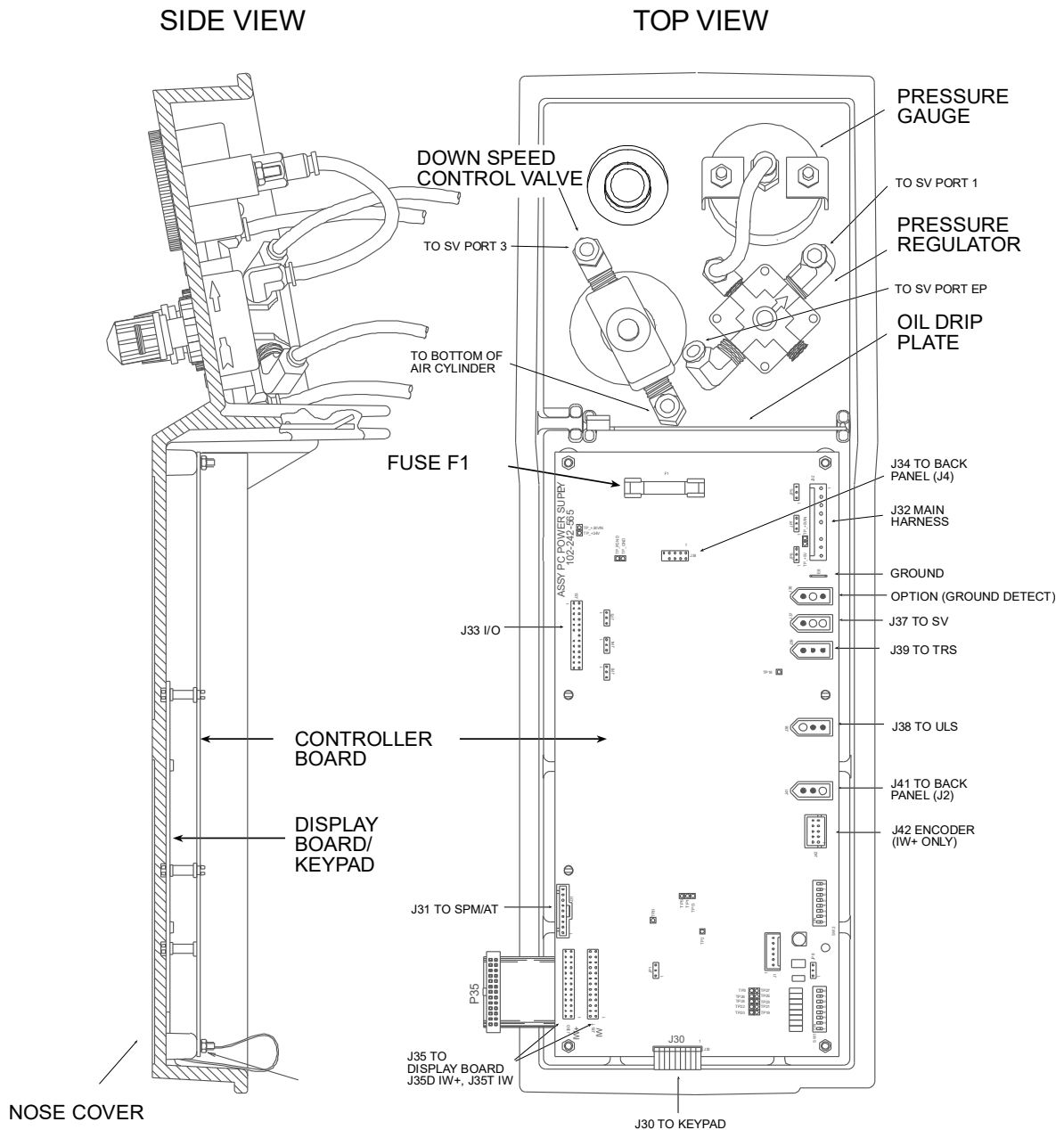

WARNING	General Warning
	<p>Before servicing the welder, make sure to do the following:</p> <ol style="list-style-type: none"> <li>1. Turn off the welder and unplug main power.</li> <li>2. Turn air pressure to zero and disconnect your main air line connection. Failure to do this leaves the welder under potentially dangerous air pressure.</li> <li>3. Wait approximately 5 minutes after unplugging the welder before touching internal electrical components.</li> </ol>

### 5.5.1 Removing the Nose Assembly

1. Turn off the welder and unplug main power.
2. Turn air pressure to zero, then disconnect main air supply.

WARNING	General Warning
	<p>Turn air pressure to zero and disconnect the main air supply. Failure to do this leave the welder under potentially dangerous air pressure.</p>

3. Open the left side cover. See Section [5.3 Opening and Removing the Left Side Cover \(EDP 100-032-338\)](#).
4. Unplug all electrical connections to the Controller Board ([Figure 5.13 Nose Assembly Components and Connections](#)).
5. Label and disconnect the air lines to the Pressure Regulator and Down Speed Control Valve ([Figure 5.13 Nose Assembly Components and Connections](#)).

**Figure 5.14** Removing the Nose Assembly

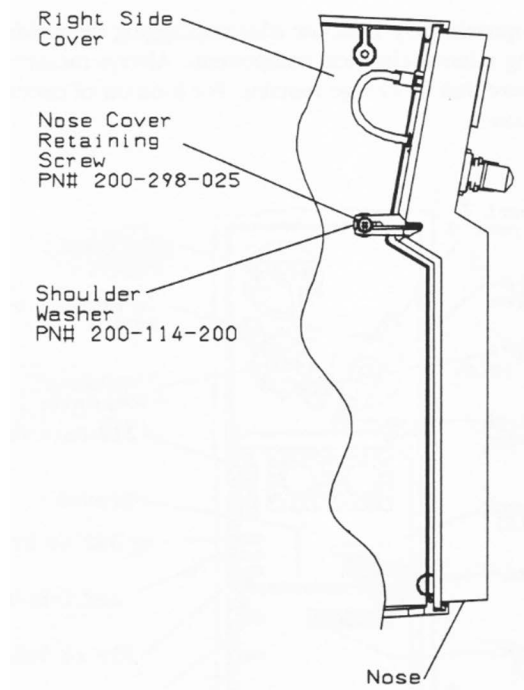

6. Hold the nose assembly in place, then remove the nose-retaining screw ([Figure 5.14 Removing the Nose Assembly](#)).
7. Slide the nose assembly off the right side cover ([Figure 5.14 Removing the Nose Assembly](#)).

### 5.5.1.1 Replacing the Nose Assembly

1. If you have removed the oil drip plate ([Figure 5.13 Nose Assembly Components and Connections](#)), replace the plate with the dimples and tab facing up.
2. Plug P31 into the Controller Board ([Figure 5.13 Nose Assembly Components and Connections](#)).
3. Slide the nose assembly onto the right side cover ([Figure 5.14 Removing the Nose Assembly](#)).
4. Hold the nose assembly in place; insert and tighten the nose retaining screw ([Figure 5.14 Removing the Nose Assembly](#)).
5. Plug all remaining electrical connections into the Control Module ([Figure 5.13 Nose Assembly Components and Connections](#)).
6. Connect the air lines to Pressure Regulator and Down Speed Control Valve ([Figure 5.13 Nose Assembly Components and Connections](#)).
7. Connect the main air supply.
8. Close the left side cover. See Section [5.3 Opening and Removing the Left Side Cover \(EDP 100-032-338\)](#).

## 5.5.2 Control Module

The Control Module is a two-board set consisting of the Controller Board and the Display board. To access the Control Module, you must open the left side cover and remove the nose assembly.

WARNING	General Warning
	<p>Before servicing the welder, make sure to do the following:</p> <ol style="list-style-type: none"> <li>1. Turn off the welder and unplug main power.</li> <li>2. Turn air pressure to zero and disconnect your main air line connection. Failure to do this leaves the welder under potentially dangerous air pressure.</li> <li>3. Wait approximately 5 minutes after unplugging the welder before touching internal electrical components.</li> </ol>

CAUTION	General Warning
	<p>The welder contains static-sensitive printed circuit (PC) boards. Irreversible damage can occur to these boards if they receive a static discharge from tools or service personnel. To prevent damage to PC boards:</p> <ol style="list-style-type: none"> <li>1. Always service a PC board on a static-dissipative surface, while wearing a properly grounded wrist strap. Follow the manufacturer's instructions for proper use of this equipment.</li> <li>2. For ground points, refer to schematic diagrams in <a href="#">Chapter 3: Schematics</a>.</li> </ol>

CAUTION	General Warning
	<p>Take precautions not to leave any loose objects (such as screws, bolts, nuts, and so forth) in the welder. If you drop an object into the welder, <i>retrieve the object immediately</i>.</p>

The following Table shows IW and IW+ settings for P35 and JP8.

**Table 5.2** IW and IW+ Connections for P35 and JP8

Connector	For IW+, connect to	For IW, connect to
P35	J35D	J35T
JP8	Pins 1 and 2	Pins 2 and 3

## 5.5.2.1 Removing the Controller Board

CAUTION	General Warning
	<p>Be careful not to leave any loose components (such as screws, bolts, nuts, and so forth) in the welder.</p>

**Figure 5.15** Removing the Controller Board

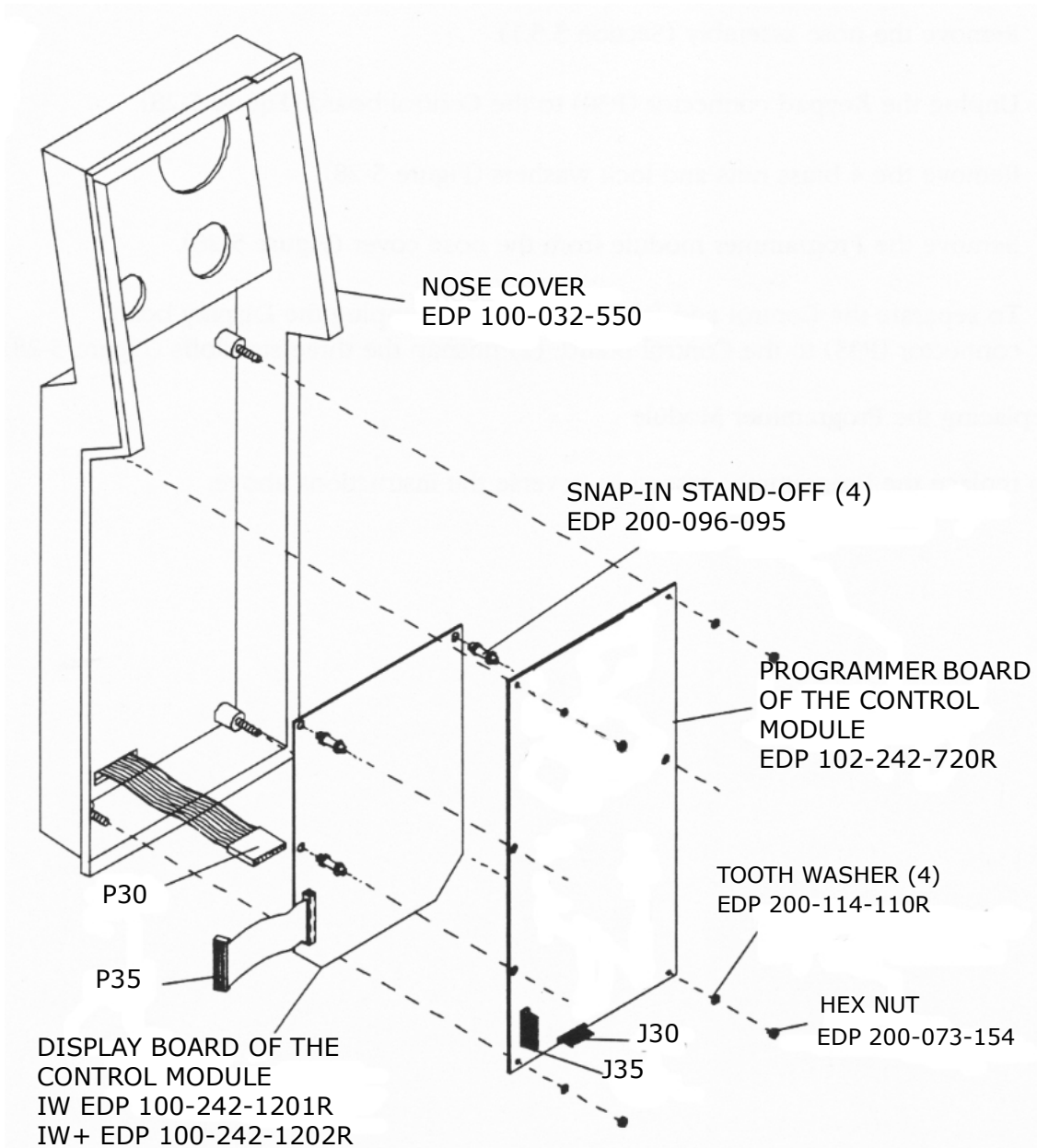

1. Turn off the welder and unplug main power.
2. Turn air pressure to zero, then disconnect main air supply.

WARNING	General Warning
	<p>Turn air pressure to zero and disconnect the main air supply. Failure to do this leave the welder under potentially dangerous air pressure.</p>

3. Open the left side cover. See Section [5.3 Opening and Removing the Left Side Cover \(EDP 100-032-338\)](#).
4. Remove the nose assembly (Section [5.5.1 Removing the Nose Assembly](#)).
5. Unplug the Keypad connector (P30) to the Control board (Figure [Figure 5.15 Removing the Controller Board](#)).
6. Remove the 4 brass nuts and lock washers ([Figure 5.15 Removing the Controller Board](#)).
7. Remove the Controller Board from the nose cover (Figure [Figure 5.15 Removing the Controller Board](#)).
8. To separate the Controller and Display boards: (1) unplug the Display board connector (P35) to the Controller Board; unsnap the four standoffs ([Figure 5.15 Removing the Controller Board](#)).

NOTICE	
	<p>If replacing the Display board, remove the four standoffs and the short standoff (<a href="#">Figure 5.15 Removing the Controller Board</a>). Insert the four standoffs into the replacement Display board. Attach the Display board to the Controller Board and replace the Control module.</p>

### 5.5.2.2 Replacing the Controller Board

To replace the Controller Board, reverse the instructions above.

## 5.5.3 Keypad (EDP IW 100-242-560; EDP IW+ 100-242-561)

### 5.5.3.1 Removing the Keypad

1. Turn off the welder and unplug main power.
2. Turn air pressure to zero, then disconnect main air supply.

WARNING	General Warning
	Turn air pressure to zero and disconnect the main air supply. Failure to do this leave the welder under potentially dangerous air pressure.

3. Open the left side cover. See Section [5.3 Opening and Removing the Left Side Cover \(EDP 100-032-338\)](#).
4. Remove the nose assembly (Section [5.5.1 Removing the Nose Assembly](#)).
5. Unplug the Keypad cable connector (P30) from the Control Module ([5.5.3.1 Removing the Keypad](#)).
6. Peel the Keypad off the nose cover ([5.5.3.1 Removing the Keypad](#)).
7. Pull the Keypad cable through the nose cover.
8. Remove any adhesive remaining on the nose cover.

### 5.5.3.2 Replacing the Keypad

**Figure 5.16** Replacing the Keypad

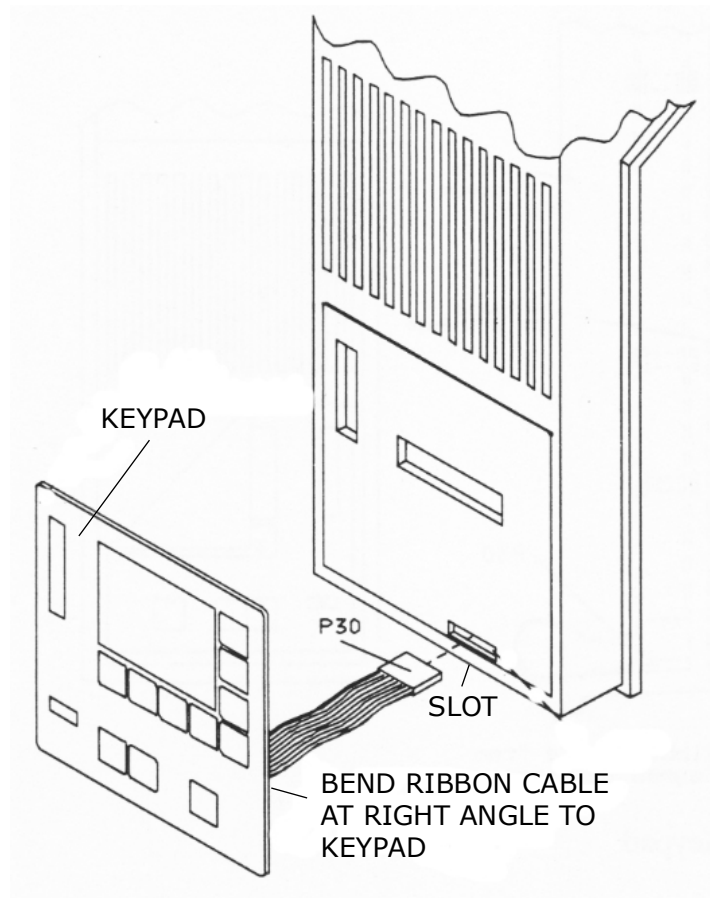

CAUTION	General Warning
	<p>Be careful when installing the new Keypad. You cannot attach the Keypad to the nose cover more than once.</p>

1. Bend the Keypad cable so it forms a right angle with the Keypad
2. Push the Keypad cable connector (P30) through the slot in the nose cover ([Figure 5.16 Replacing the Keypad](#)).
3. Peel the adhesive strip off the back of the Keypad.
4. Carefully align the bottom edge of the Keypad with the bottom of the Keypad inset ([Figure 5.16 Replacing the Keypad](#)).
5. Press the Keypad evenly until firmly attached to the nose cover.
6. Plug the Keypad cable connector (P30) into the Control board ([5.5.3.1 Removing the Keypad](#)).
7. Connect the main air supply.
8. Close the left side cover. See Section [5.3 Opening and Removing the Left Side Cover \(EDP 100-032-338\)](#).

## 5.5.4 Pressure Regulator (EDP 100-246-692)

WARNING	General Warning
	<p>Before servicing the welder, make sure to do the following:</p> <ol style="list-style-type: none"> <li>1. Turn off the welder and unplug main power.</li> <li>2. Turn air pressure to zero and disconnect your main air line connection. Failure to do this leaves the welder under potentially dangerous air pressure.</li> <li>3. Wait approximately 5 minutes after unplugging the welder before touching internal electrical components.</li> </ol>

**Figure 5.17** Removing the Pressure Regulator

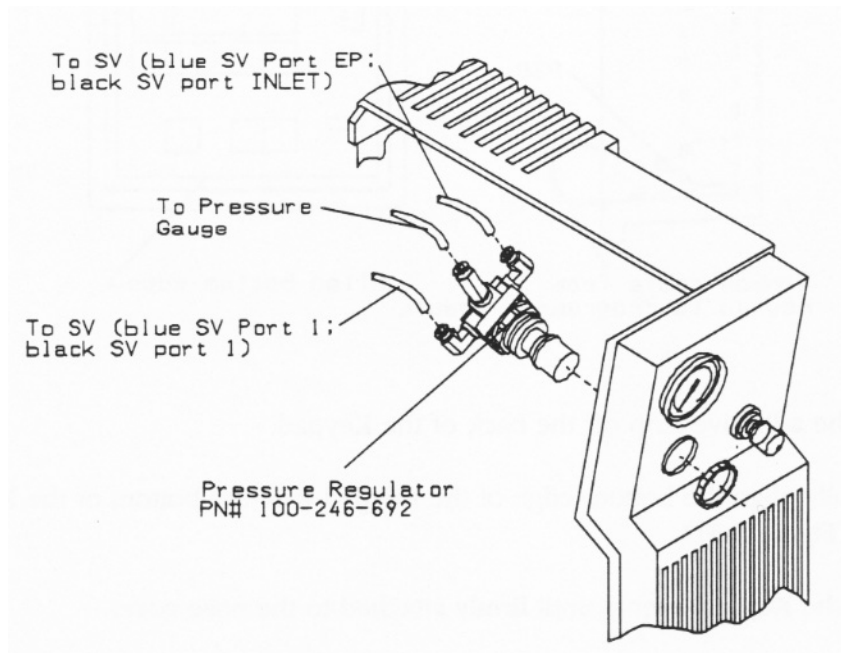

### 5.5.4.1 Removing the Pressure Regulator

1. Turn off the welder and unplug main power.
2. Turn air pressure to zero, then disconnect main air supply.

WARNING	General Warning
	<p>Turn air pressure to zero and disconnect the main air supply. Failure to do this leave the welder under potentially dangerous air pressure.</p>

3. Open the left side cover. See Section [5.3 Opening and Removing the Left Side Cover \(EDP 100-032-338\)](#).
4. Disconnect the three air lines to the Pressure Regulator ([Figure 5.17 Removing the Pressure Regulator](#)).

5. Loosen and remove the retaining ring nut. You can do this two ways:
  - hold the retaining ring nut while turning the Pressure Regulator; or
  - hold the Pressure Regulator and loosen the retaining ring nut with pliers.
6. Remove the Pressure Regulator from the welder ([Figure 5.17 Removing the Pressure Regulator](#)).

## 5.5.4.2 Replacing the Pressure Regulator

CAUTION	General Warning
	<p>Turn the new Pressure Regulator knob fully counterclockwise.</p>

**Figure 5.18** Replacing the Pressure Regulator

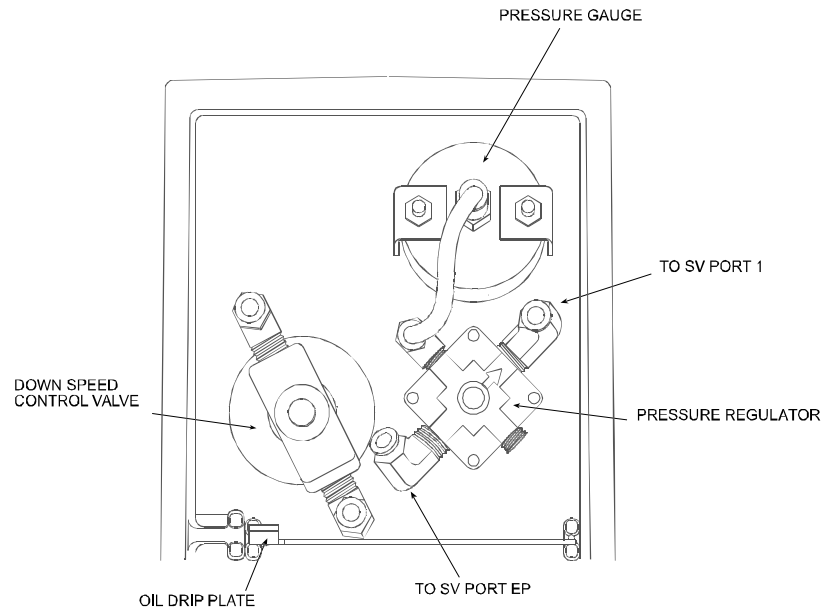

1. Place the Pressure Regulator into the welder as shown in [Figure 5.18 Replacing the Pressure Regulator](#). Tilt the Pressure Regulator approximately 45 degrees with the arrow on the back of the Pressure Regulator pointing up.
2. Hold the Pressure Regulator in place; then install and tighten the retaining ring nut.
3. Connect the three air lines to the Pressure Regulator ([Figure 5.18 Replacing the Pressure Regulator](#)).

WARNING	General Warning
	<p>Make sure all air lines are securely connected. Failure to do this can cause air pressure to disconnect an insecure air line when turning air pressure on.</p>

4. Connect the main air supply.
5. Close the left side cover. See Section [5.3 Opening and Removing the Left Side Cover \(EDP 100-032-338\)](#).

## 5.5.5 Pressure Gauge (EDP 100-246-691)

WARNING	General Warning
	<p>Before servicing the welder, make sure to do the following:</p> <ol style="list-style-type: none"> <li>1. Turn off the welder and unplug main power.</li> <li>2. Turn air pressure to zero and disconnect your main air line connection. Failure to do this leaves the welder under potentially dangerous air pressure.</li> <li>3. Wait approximately 5 minutes after unplugging the welder before touching internal electrical components.</li> </ol>

**Figure 5.19** Removing the Pressure Gauge

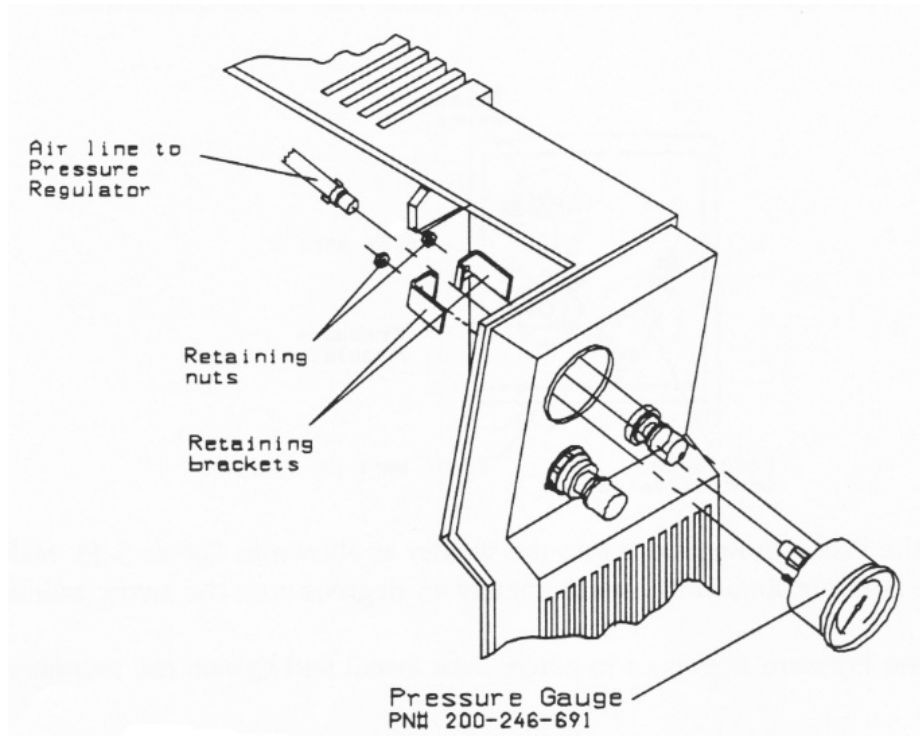

### 5.5.5.1 Removing the Pressure Gauge

1. Turn off the welder and unplug main power.

- Turn air pressure to zero, then disconnect main air supply.

WARNING	General Warning
	<p>Turn air pressure to zero and disconnect the main air supply. Failure to do this leave the welder under potentially dangerous air pressure.</p>

- Open the left side cover. See [5.3 Opening and Removing the Left Side Cover \(EDP 100-032-338\)](#).
- Disconnect the air line from the Pressure Gauge ([Figure 5.19 Removing the Pressure Gauge](#)).
- Hold the pressure gauge against the nose cover; then loosen the two retaining nuts ([Figure 5.19 Removing the Pressure Gauge](#)).
- Remove the retaining nuts and brackets ([Figure 5.19 Removing the Pressure Gauge](#)).
- From the front of the welder, pull the Pressure Gauge out of the welder ([Figure 5.19 Removing the Pressure Gauge](#)).

#### 5.5.5.2 Replacing the Pressure Gauge

To replace the Pressure Gauge, reverse the instructions above.

WARNING	General Warning
	<p>Make sure all air lines are securely connected. Failure to do this can cause air pressure to disconnect an insecure air line when turning air pressure on.</p>

## 5.5.6 Down Speed Control Valve (EDP 100-246-693)

WARNING	General Warning
	<p>Before servicing the welder, make sure to do the following:</p> <ol style="list-style-type: none"> <li>1. Turn off the welder and unplug main power.</li> <li>2. Turn air pressure to zero and disconnect your main air line connection. Failure to do this leaves the welder under potentially dangerous air pressure.</li> <li>3. Wait approximately 5 minutes after unplugging the welder before touching internal electrical components.</li> </ol>

**Figure 5.20** Removing the Down Speed Control Valve

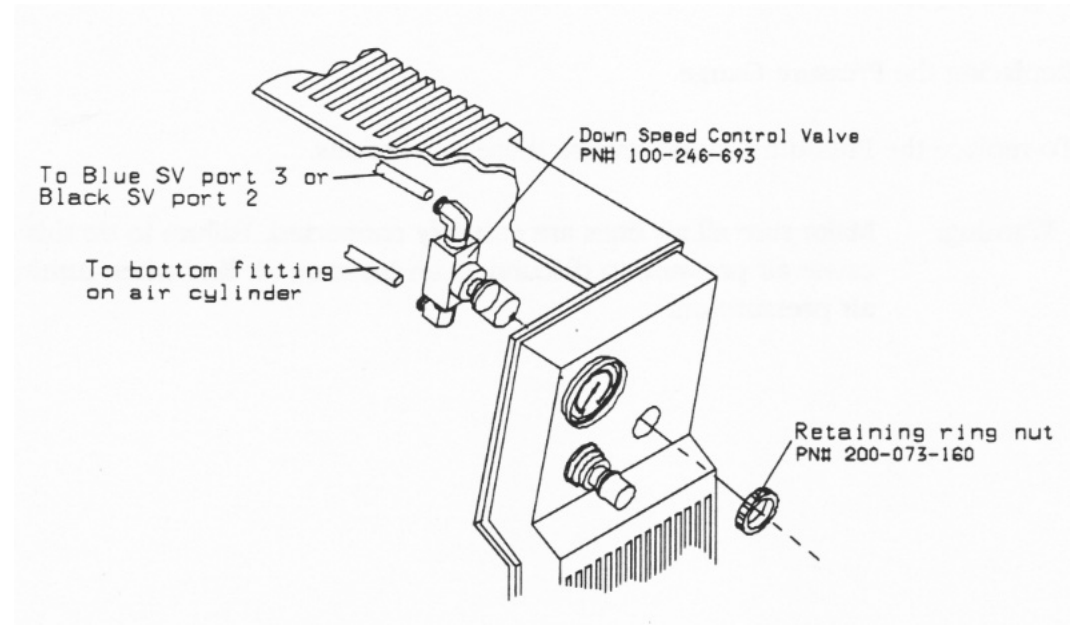

### 5.5.6.1 Removing the Down Speed Control Valve

1. Turn off the welder and unplug main power.
2. Turn air pressure to zero, then disconnect main air supply.

WARNING	General Warning
	<p>Turn air pressure to zero and disconnect the main air supply. Failure to do this leave the welder under potentially dangerous air pressure.</p>

3. Open the left side cover. See [5.3 Opening and Removing the Left Side Cover \(EDP 100-032-338\)](#).
4. Disconnect the two air lines to the Down Speed Control Valve ([Figure 5.20 Removing the Down Speed Control Valve](#)).
5. Loosen and remove the retaining ring nut. You can do this two ways:

- hold the retaining ring nut while turning the Down Speed Control Valve; or
  - hold the Down Speed Control Valve and turn the retaining ring nut with pliers
6. Remove the Down Speed Control Valve from the welder.

### 5.5.6.2 Replacing the Down Speed Control Valve

1. Check both sides for the new Down Speed Control Valve: one side has an arrow.
2. Place the Down Speed Control Valve into the welder so the arrow points up and tilt the valve as shown in [Figure 5.18 Replacing the Pressure Regulator](#).
3. Hold the valve against the nose cover; then install and tighten the retaining ring nut.
4. Connect the two air lines to the Down Speed Control Valve ([Figure 5.18 Replacing the Pressure Regulator](#)).

WARNING	General Warning
	<p>Make sure all air lines are securely connected. Failure to do this can cause air pressure to disconnect an insecure air line when turning air pressure on.</p>

5. Connect the main air supply.
6. Close the left side cover. See [5.3 Opening and Removing the Left Side Cover \(EDP 100-032-338\)](#).

### 5.5.7 Main Support Assembly

This section covers removing and replacing the following components in the Main Support Assembly:

- Converter-Booster-Horn Stack
- Trigger Guard
- Air Cylinder
- Dynamic Trigger Mechanism
- RF Contact Block
- Carriage Return Spring
- Upper Limit Switch (ULS)
- Trigger Switch (TRS)
- Linear Optical Encoder

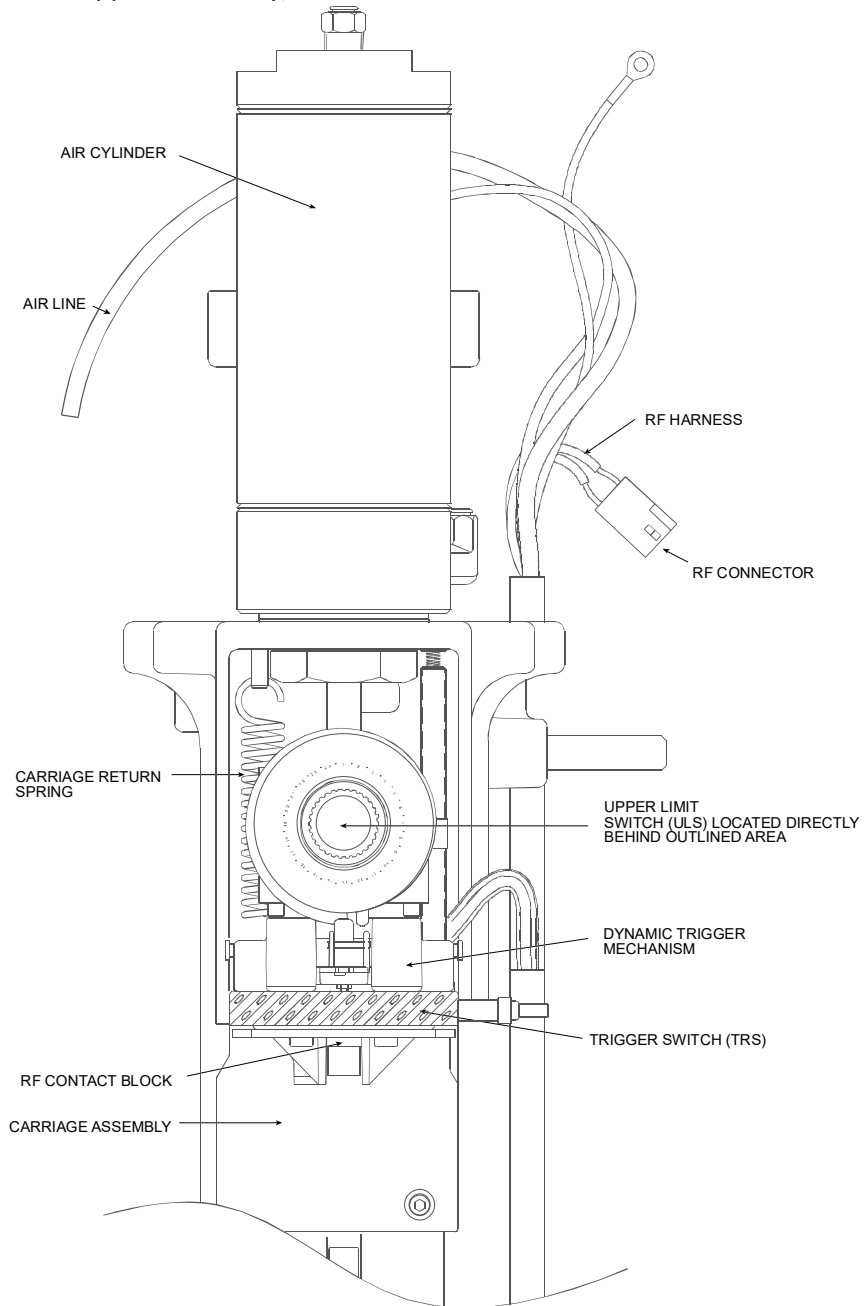

NOTICE	
	<p>If you need to replace the RF Harness (EDP 100-241-086), the column, or the Counterbalance spring (EDP 100-095-023), contact your local Branson representative.</p>

**Figure 5.21** Main Support Assembly, Front View

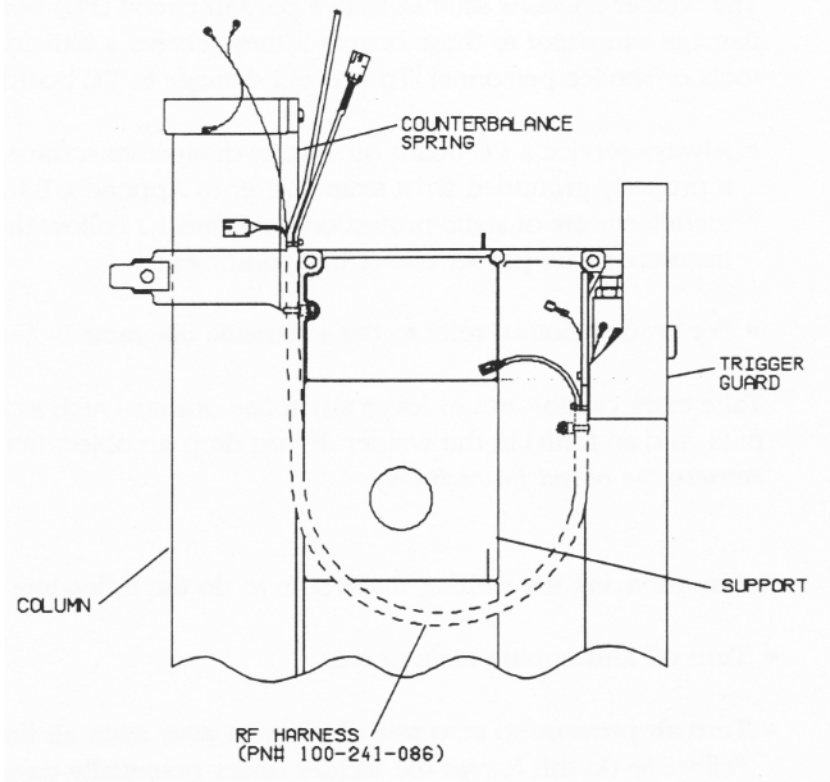

**Figure 5.22** Main Support Assembly, Side View



WARNING	General Warning
	<p>Before servicing the welder, make sure to do the following:</p> <ol style="list-style-type: none"> <li>1. Turn off the welder and unplug main power.</li> <li>2. Turn air pressure to zero and disconnect your main air line connection. Failure to do this leaves the welder under potentially dangerous air pressure.</li> <li>3. Wait approximately 5 minutes after unplugging the welder before touching internal electrical components.</li> </ol>
CAUTION	General Warning
	<p>Take extra caution not to leave any loose objects (such as screws, bolts, nuts, and so forth) in the welder. If you drop an object into the welder, retrieve the object immediately.</p>

## 5.5.8 Converter-Booster-Horn Stack

You must remove the Converter-Booster-Horn Stack to service the Dynamic Trigger Mechanism, the Trigger switch (TRS), and the Air Cylinder.

WARNING	General Warning
	<p>Before servicing the welder, make sure to do the following:</p> <ol style="list-style-type: none"> <li>1. Turn off the welder and unplug main power.</li> <li>2. Turn air pressure to zero and disconnect your main air line connection. Failure to do this leaves the welder under potentially dangerous air pressure.</li> <li>3. Wait approximately 5 minutes after unplugging the welder before touching internal electrical components.</li> </ol>

WARNING	General Warning
	<p>If LED 1 or LED 2 on the Power Supply Module is lit, there is still High Voltage present. Wait until they are out before servicing the welder. Refer to <a href="#">Figure 3.4</a> for location of LED 1 and 2.</p>

### 5.5.8.1 Removing the Converter-Booster-Horn Stack

**Figure 5.23** Removing the Converter-Booster-Horn Stack

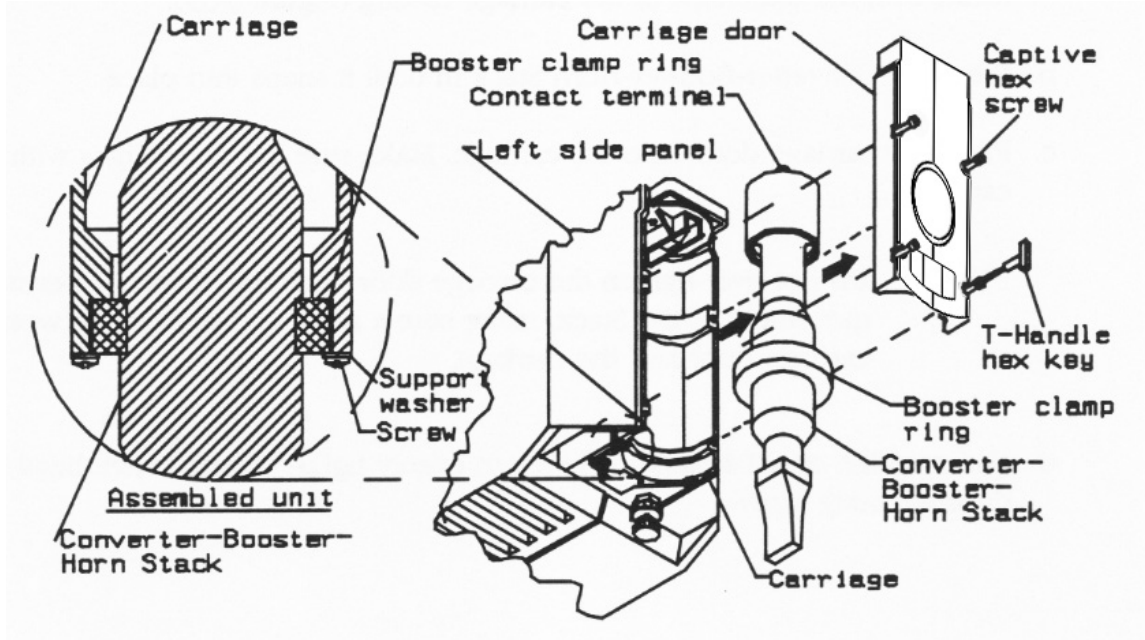

1. Turn off the welder and unplug main power.
2. Turn air pressure to zero, then disconnect main air supply.

WARNING	General Warning
	<p>Turn air pressure to zero and disconnect the main air supply. Failure to do this leave the welder under potentially dangerous air pressure.</p>

3. Use an Allen or T-handle wrench to loosen the four hex-head ([Figure 5.23 Removing the Converter-Booster-Horn Stack](#)) carriage door captive retaining screws.
4. Remove the carriage door.
5. Pull the Converter-Booster-Horn Stack out of the carriage.

### 5.5.8.2 Replacing the Converter-Booster-Horn Stack

1. Lift the Converter-Booster-Horn Stack (acorn contact terminal facing up) onto the carriage. Slide the bottom of the booster clamp ring onto the two support washers located on the underside of the carriage casting ([Figure 5.23 Removing the Converter-Booster-Horn Stack](#)).
2. Press the Converter-Booster-Horn Stack in until it snaps into place.
3. Place the carriage door onto the carriage. Make sure the door aligns with the carriage.

NOTICE	
	<p>Do not over-tighten the carriage door retaining screws. To ensure free movement of the Stack, make sure a small gap remains between the carriage door and the carriage.</p>

4. Use an Allen or a T-handled wrench to evenly tighten the four hex-head carriage door retaining screws.

### 5.5.9 Trigger Guard (EDP 100-208-045)

You must remove the Trigger Guard to service the Dynamic Trigger Mechanism, the Trigger switch (TRS), the Upper Limit Switch (ULS), and the Air Cylinder.

WARNING	General Warning
	<p>Before servicing the welder, make sure to do the following:</p> <ol style="list-style-type: none"> <li>1. Turn off the welder and unplug main power.</li> <li>2. Turn air pressure to zero and disconnect your main air line connection. Failure to do this leaves the welder under potentially dangerous air pressure.</li> <li>3. Wait approximately 5 minutes after unplugging the welder before touching internal electrical components.</li> </ol>

**Figure 5.24** Removing the Trigger Guard

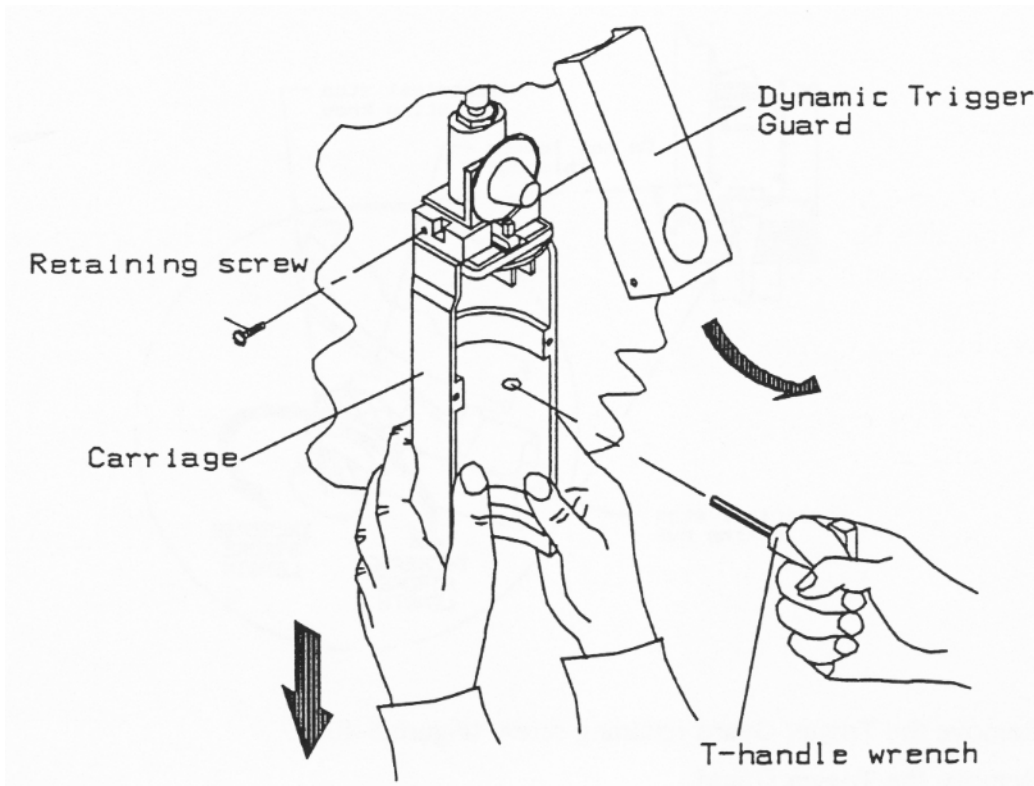

### 5.5.9.1 Removing the Trigger Guard

1. Turn off the welder and unplug main power.
2. Turn air pressure to zero, then disconnect main air supply.

WARNING	General Warning
	<p>Turn air pressure to zero and disconnect the main air supply. Failure to do this leave the welder under potentially dangerous air pressure.</p>

3. Open the left side cover. See [5.3 Opening and Removing the Left Side Cover \(EDP 100-032-338\)](#).
4. Remove the Converter-Booster-Horn Stack (Section [5.5.8.1 Removing the Converter-Booster-Horn Stack](#)).
5. Lower the carriage and insert a T-handle wrench (or similar tool) as shown in [Figure 5.23 Removing the Converter-Booster-Horn Stack](#). If you need to lower the carriage further, adjust the Mechanical Stop as shown in [Figure 5.25 Adjusting the Mechanical Stop](#).

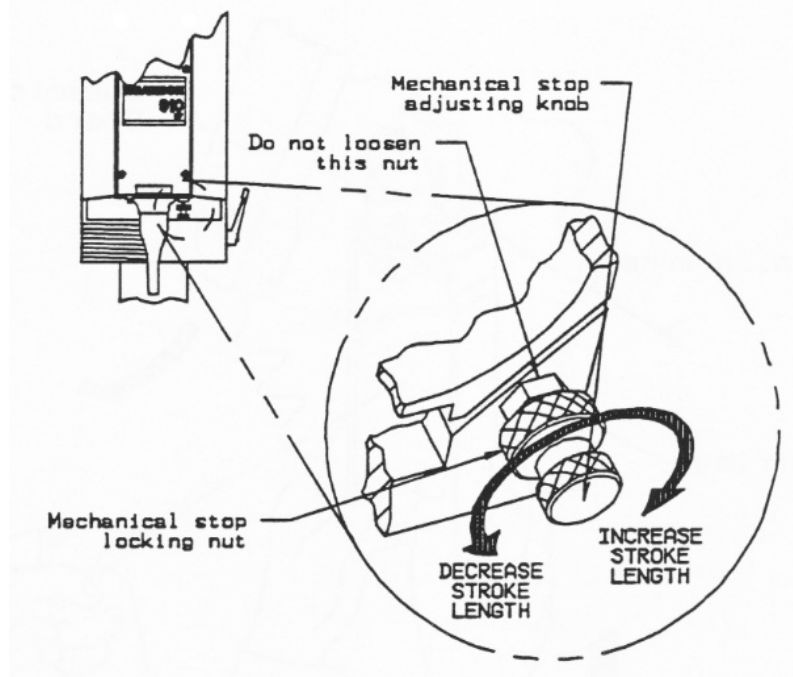
**Figure 5.25** Adjusting the Mechanical Stop

6. Remove the Trigger Guard retaining screw ([Figure 5.24 Removing the Trigger Guard](#)).
7. Remove the Trigger Guard.

### 5.5.9.2 Replacing the Trigger Guard

1. Place the Trigger Guard onto the welder and insert the retaining screw, but *do not tighten*.

CAUTION	General Warning
	<p>Make sure to install the Trigger Guard so it does not contact the Main Support. If the Trigger Guard contacts the Main Support during a weld cycle, an alarm can occur.</p>

2. Pull the top of the Trigger Guard away from the Main Support. When the Trigger Guard no longer contacts the Main Support, hold the Trigger Guard in place and tighten the retaining screw.
3. Check for proper installation of the Trigger Guard:
4. Push the Trigger Guard towards the main support. If the Trigger Guard flexes, it is properly installed.
5. If it does not flex, loosen the retaining screw and repeat step 2.
6. Install the Converter-Booster-Horn Stack (Section [5.5.8.1 Removing the Converter-Booster-Horn Stack](#)).
7. Connect the main air supply.
8. Close the left side cover. See [5.3 Opening and Removing the Left Side Cover \(EDP 100-032-338\)](#).

## 5.5.10 Air Cylinder

To remove the Air Cylinder you will need two open-ended wrenches. [Table 5.3 Air Cylinder Part Numbers](#) lists the Air Cylinder part numbers and the wrenches needed to remove an Air Cylinder.

WARNING	General Warning
	<p>Before servicing the welder, make sure to do the following:</p> <ol style="list-style-type: none"> <li>1. Turn off the welder and unplug main power.</li> <li>2. Turn air pressure to zero and disconnect your main air line connection. Failure to do this leaves the welder under potentially dangerous air pressure.</li> <li>3. Wait approximately 5 minutes after unplugging the welder before touching internal electrical components.</li> </ol>

**Table 5.3** Air Cylinder Part Numbers

Air Cylinder Size	Part Number	Wrench Size
2-1/2 in. x 4 in.	100-246-576	3/4 in. and 1/2 in.
3 in. x 4 in.	100-246-573	3/4 in. and 5/8 in.

NOTICE	
	<p>These Air Cylinder Part Numbers are for replacement. If you are converting to another cylinder size, contact Branson Product Support for the correct conversion kit.</p>

**Figure 5.26** Removing the Air Cylinder, Part A

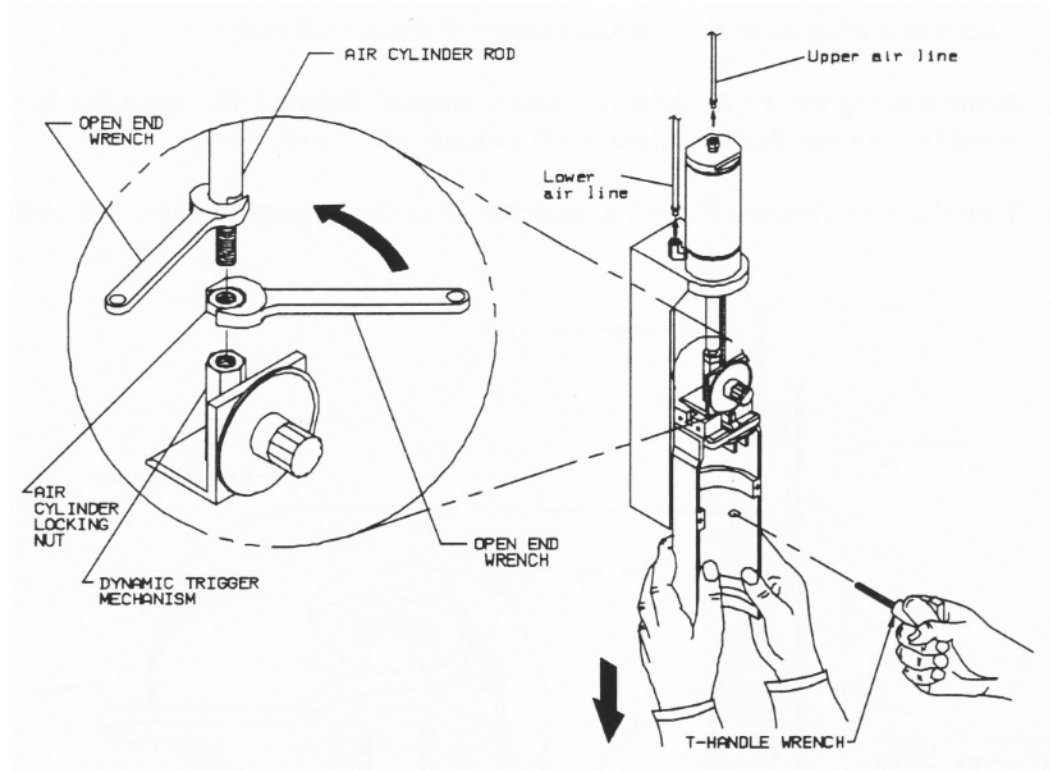

### 5.5.10.1 Removing the Air Cylinder

1. Turn off the welder and unplug main power.
2. Turn air pressure to zero, then disconnect main air supply.

WARNING	General Warning
	<p>Turn air pressure to zero and disconnect the main air supply. Failure to do this leave the welder under potentially dangerous air pressure.</p>

3. Open the left side cover. See [5.3 Opening and Removing the Left Side Cover \(EDP 100-032-338\)](#).
4. Remove the Converter-Booster-Horn Stack (Section [5.5.8.1 Removing the Converter-Booster-Horn Stack](#)).
5. Remove the Trigger Guard.

WARNING	General Warning
	<p>Pinch Warning.</p>

6. Disconnect air lines to the top and bottom of the Air Cylinder.
7. While holding the Air Cylinder rod with a wrench ([Table 5.3 Air Cylinder Part Numbers](#)), use a 3/4 in. wrench to loosen the Air Cylinder rod locking nut. See [Figure 5.26 Removing the Air Cylinder, Part A](#).
8. Turn the Air Cylinder rod until it separated from the Dynamic Trigger Mechanism.

**Figure 5.27** Removing the Air Cylinder, Part B

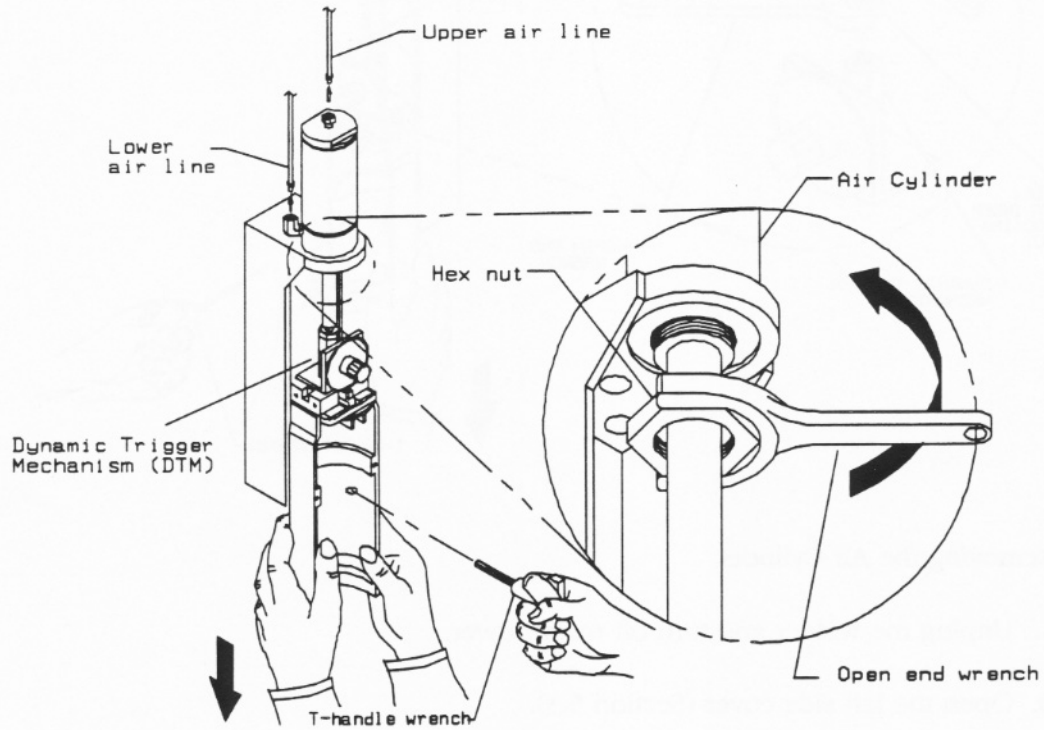

9. Use a 1-7/8 in. crow foot wrench to loosen and remove the large hex-head nut ([Figure 5.27 Removing the Air Cylinder, Part B](#)).
10. Remove the Air Cylinder by pulling up and out of the welder.

### 5.5.10.2 Replacing the Air Cylinder

To replace the Air Cylinder, reverse the instructions above. Apply one or two drops of Loctite® 242 (or equivalent) to all threaded connections.

### 5.5.11 Dynamic Trigger Mechanism (EDP 100-246-697)

WARNING	General Warning
	<p>Before servicing the welder, make sure to do the following:</p> <ol style="list-style-type: none"> <li>1. Turn off the welder and unplug main power.</li> <li>2. Turn air pressure to zero and disconnect your main air line connection. Failure to do this leaves the welder under potentially dangerous air pressure.</li> <li>3. Wait approximately 5 minutes after unplugging the welder before touching internal electrical components.</li> </ol>

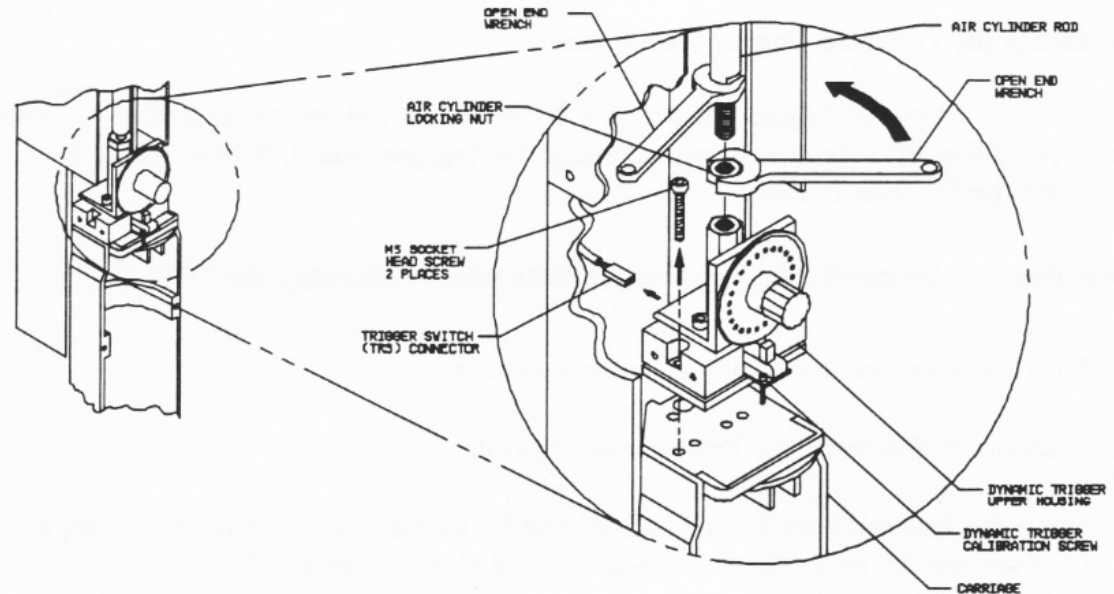
**Figure 5.28** Removing the Dynamic Trigger Mechanism**5.5.11.1 Removing the Dynamic Trigger Mechanism**

1. Turn off the welder and unplug main power.
2. Turn air pressure to zero, then disconnect main air supply.

WARNING	General Warning
	<p>Turn air pressure to zero and disconnect the main air supply. Failure to do this leave the welder under potentially dangerous air pressure.</p>

3. Open the left side cover. See [5.3 Opening and Removing the Left Side Cover \(EDP 100-032-338\)](#).
4. Remove the Converter-Booster-Horn Stack (Section [5.5.8.1 Removing the Converter-Booster-Horn Stack](#)).
5. Remove the Trigger Guard and lower the carriage (Section [5.5.9.1 Removing the Trigger Guard](#)).
6. Use a wrench ([Table 5.3 Air Cylinder Part Numbers](#)) to hold the Air Cylinder rod. Use a 3/4 in. wrench to loosen the Air Cylinder locking nut ([Figure 5.28 Removing the Dynamic Trigger Mechanism](#)).
7. Turn the Air Cylinder rod until it separates from the large hex-head nut on the Dynamic Trigger Mechanism ([Figure 5.28 Removing the Dynamic Trigger Mechanism](#)).
8. Remove the retaining screws on each side of Dynamic Trigger Mechanism ([Figure 5.28 Removing the Dynamic Trigger Mechanism](#)).
9. Remove the Dynamic Trigger Mechanism from the welder ([Figure 5.28 Removing the Dynamic Trigger Mechanism](#)):
  - Pull the Dynamic Trigger Mechanism out until you can unplug the white TRS connector
  - Remove the Dynamic Trigger Mechanism from the welder

## 5.5.11.2 Replacing the Dynamic Trigger Mechanism

Replace the Dynamic Trigger Mechanism by reversing the instructions above - except for closing the left side cover and installing the Trigger Guard. When finished, calibrate the Dynamic Trigger mechanism. For instructions on calibrating the welder, contact Branson Product Support.

## 5.5.12 RF Contact Block

WARNING	General Warning
	<p>Before servicing the welder, make sure to do the following:</p> <ol style="list-style-type: none"><li>1. Turn off the welder and unplug main power.</li><li>2. Turn air pressure to zero and disconnect your main air line connection. Failure to do this leaves the welder under potentially dangerous air pressure.</li><li>3. Wait approximately 5 minutes after unplugging the welder before touching internal electrical components.</li></ol>

**Figure 5.29** Removing the RF Contact Block

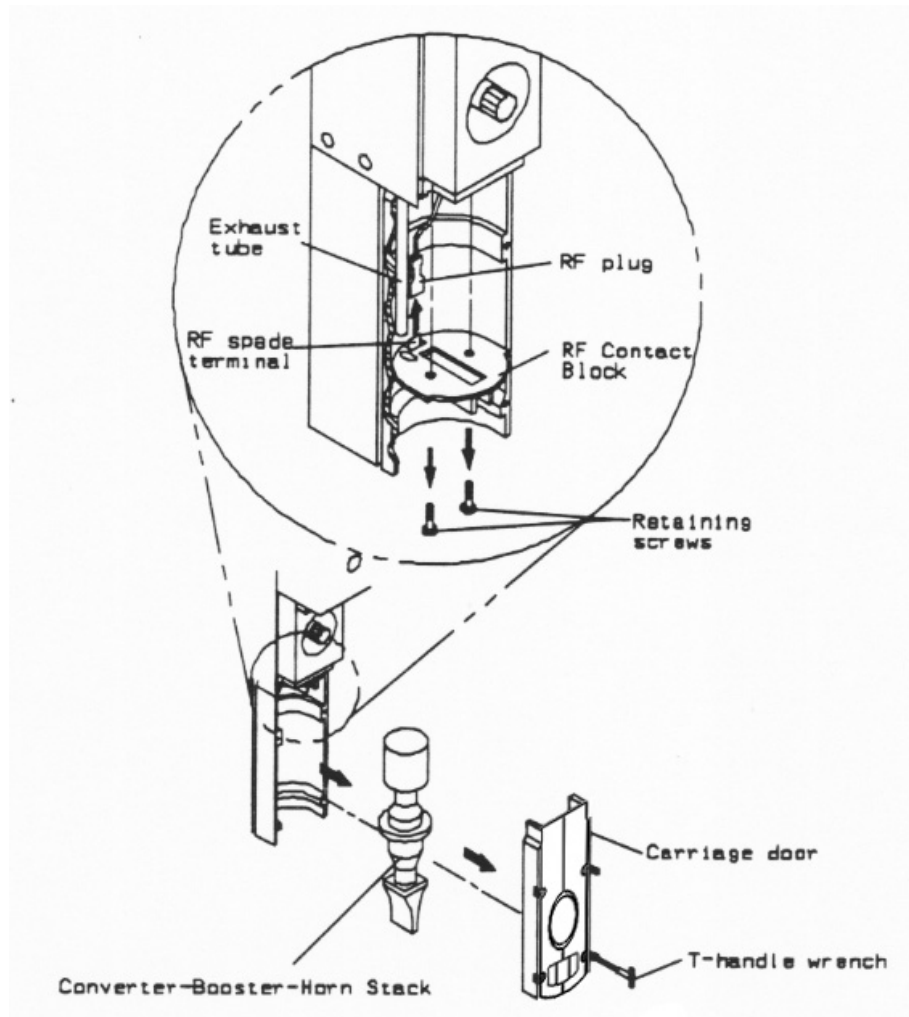

## 5.5.12.1 Removing the RF Contact Block

1. Turn off the welder and unplug main power.
2. Turn air pressure to zero, then disconnect main air supply.

WARNING	General Warning
	<p>Turn air pressure to zero and disconnect the main air supply. Failure to do this leave the welder under potentially dangerous air pressure.</p>

3. Open the left side cover. See [5.3 Opening and Removing the Left Side Cover \(EDP 100-032-338\)](#).
4. Loosen the four captive retaining screws on the carriage door and remove the carriage door.
5. Remove the Converter-Booster-Horn Stack (Section [5.5.8.1 Removing the Converter-Booster-Horn Stack](#)).
6. Remove the two Phillips retaining screws ([Figure 5.29 Removing the RF Contact Block](#)).
7. Disconnect the RF wire: hold the red wire lug with needle nose pliers, while pulling down on the RF Contact Block until the wire comes off.
8. Disconnect the exhaust tube: hold the exhaust tube while pulling down on the RF Contact Block until the tube comes off.

## 5.5.12.2 Replacing the RF Contact Block

To replace the RF Contact Block, reverse the instructions above.

## 5.5.12.3 Carriage Return Spring (EDP 100-095-139)

WARNING	General Warning
	<p>Before servicing the welder, make sure to do the following:</p> <ol style="list-style-type: none"> <li>1. Turn off the welder and unplug main power.</li> <li>2. Turn air pressure to zero and disconnect your main air line connection. Failure to do this leaves the welder under potentially dangerous air pressure.</li> <li>3. Wait approximately 5 minutes after unplugging the welder before touching internal electrical components.</li> </ol>

WARNING	General Warning
	<p>Pinch Warning.</p>

**Figure 5.30** Removing the Carriage Return Spring

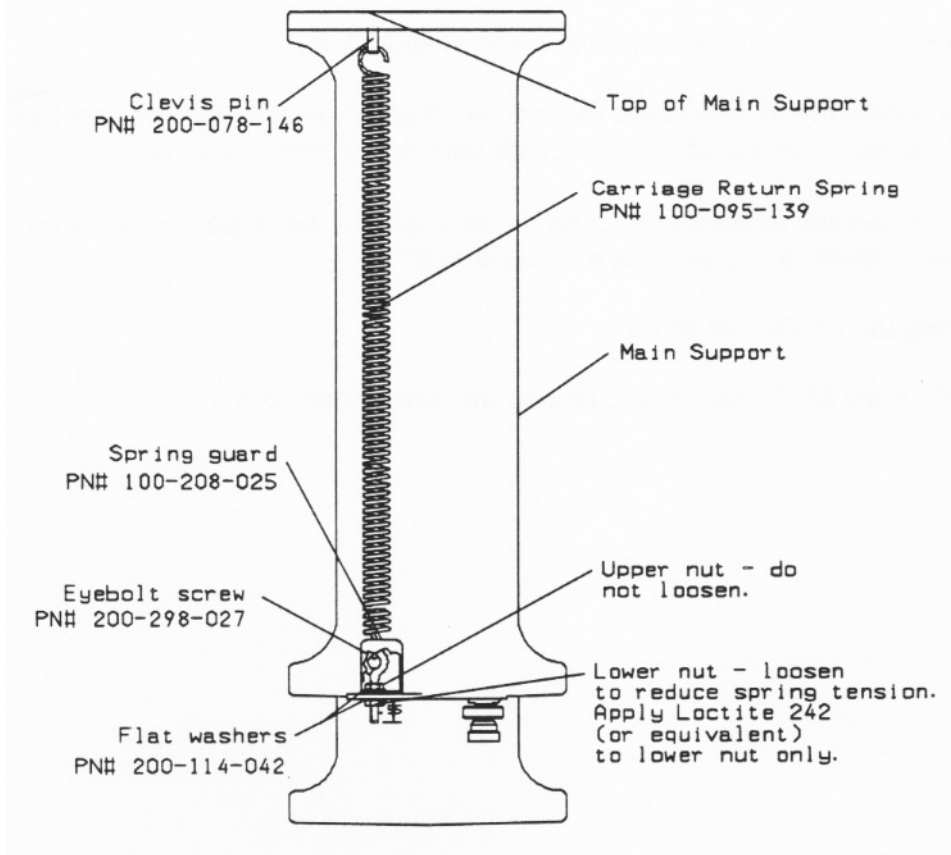

#### 5.5.12.4 Removing the Carriage Return Spring

1. Turn off the welder and unplug main power.
2. Turn air pressure to zero, then disconnect main air supply.

WARNING	General Warning
	<p>Turn air pressure to zero and disconnect the main air supply. Failure to do this leave the welder under potentially dangerous air pressure.</p>

3. Open the left side cover. See [5.3 Opening and Removing the Left Side Cover \(EDP 100-032-338\)](#).
4. Remove the Trigger Guard (Section [5.5.9.1 Removing the Trigger Guard](#)).
5. Use a 3/8 in. nutdriver to loosen - *but not remove* - the nut on the bottom of the eyebolt ([Figure 5.30 Removing the Carriage Return Spring](#)).
6. Remove the spring guard ([Figure 5.30 Removing the Carriage Return Spring](#)). (If you need more room to free the spring guard, lower the carriage).
7. Grasp the middle of the spring and pull down on it while unhooking the spring from the eyebolt.
8. Unhook the top of the spring from the Clevis pin coming through the top of the main support ([Figure 5.30 Removing the Carriage Return Spring](#)).

### 5.5.12.5 Replacing the Carriage Return Spring

1. Insert the Clevis pin through the top of the main support ([Figure 5.30 Removing the Carriage Return Spring](#)).
2. Hook the top of the spring through the hole in the Clevis pin.
3. Hook the bottom of the spring through the eyebolt ([Figure 5.30 Removing the Carriage Return Spring](#)).
4. Install the spring guard.
5. Hold the spring guard in place and tighten the lower nut on the eyebolt ([Figure 5.30 Removing the Carriage Return Spring](#)).
6. Tighten the eyebolt until the distance between the bottom of the support and the end of the eyebolt equals 0.55 in. ([Figure 5.30 Removing the Carriage Return Spring](#)).
7. Install the Trigger Guard (Section [5.5.9.2 Replacing the Trigger Guard](#)).
8. Connect the main air supply.
9. Close the left side cover. See [5.3 Opening and Removing the Left Side Cover \(EDP 100-032-338\)](#).

### 5.5.13 Upper Limit Switch (EDP 200-099-190R)

WARNING	General Warning
	<p>Before servicing the welder, make sure to do the following:</p> <ol style="list-style-type: none"> <li>1. Turn off the welder and unplug main power.</li> <li>2. Turn air pressure to zero and disconnect your main air line connection. Failure to do this leaves the welder under potentially dangerous air pressure.</li> <li>3. Wait approximately 5 minutes after unplugging the welder before touching internal electrical components.</li> </ol>

**Figure 5.31** Removing the Upper Limit Switch (ULS)

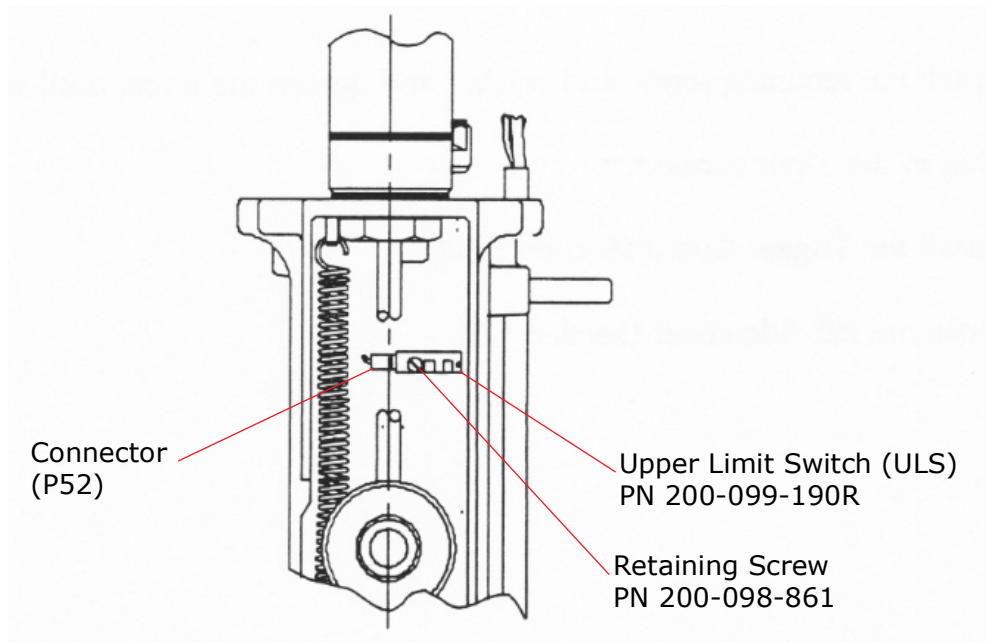

## 5.5.14 Removing the Upper Limit Switch (ULS)

1. Turn off the welder and unplug main power.
2. Turn air pressure to zero, then disconnect main air supply.

WARNING	General Warning
	<p>Turn air pressure to zero and disconnect the main air supply. Failure to do this leave the welder under potentially dangerous air pressure.</p>

3. Open the left side cover. See [5.3 Opening and Removing the Left Side Cover \(EDP 100-032-338\)](#).
4. Remove the Trigger Guard (Section [5.5.9.1 Removing the Trigger Guard](#)).
5. Unplug the 3-pin connector ([Figure 5.31 Removing the Upper Limit Switch \(ULS\)](#)).
6. Hold the ULS in place and remove the retaining screw ([Figure 5.31 Removing the Upper Limit Switch \(ULS\)](#)). Remove the ULS from the welder.

### 5.5.14.1 Replacing the Upper Limit Switch

1. Line the tab on the back of the ULS with the hole in the Main Support; insert the ULS onto the Main Support so the tab fits into the hole.

CAUTION	General Warning
	<p>The ULS is fragile - do not overtighten the ULS retaining screw.</p>

2. Apply one or two drops of Loctite® 242 to the retaining screw.
3. Install the retaining screw and tighten the screw until snug.
4. Plug in the 3-pin connector.
5. Install the Trigger Guard ([5.5.9.2 Replacing the Trigger Guard](#)).
6. Connect the main air supply.
7. Close the left side cover. See [5.3 Opening and Removing the Left Side Cover \(EDP 100-032-338\)](#).

## 5.5.15 Trigger Switch (TRS)

WARNING	General Warning
	<p>Before servicing the welder, make sure to do the following:</p> <ol style="list-style-type: none"> <li>1. Turn off the welder and unplug main power.</li> <li>2. Turn air pressure to zero and disconnect your main air line connection. Failure to do this leaves the welder under potentially dangerous air pressure.</li> <li>3. Wait approximately 5 minutes after unplugging the welder before touching internal electrical components.</li> </ol>

**Figure 5.32** Removing the Trigger Switch (TRS)

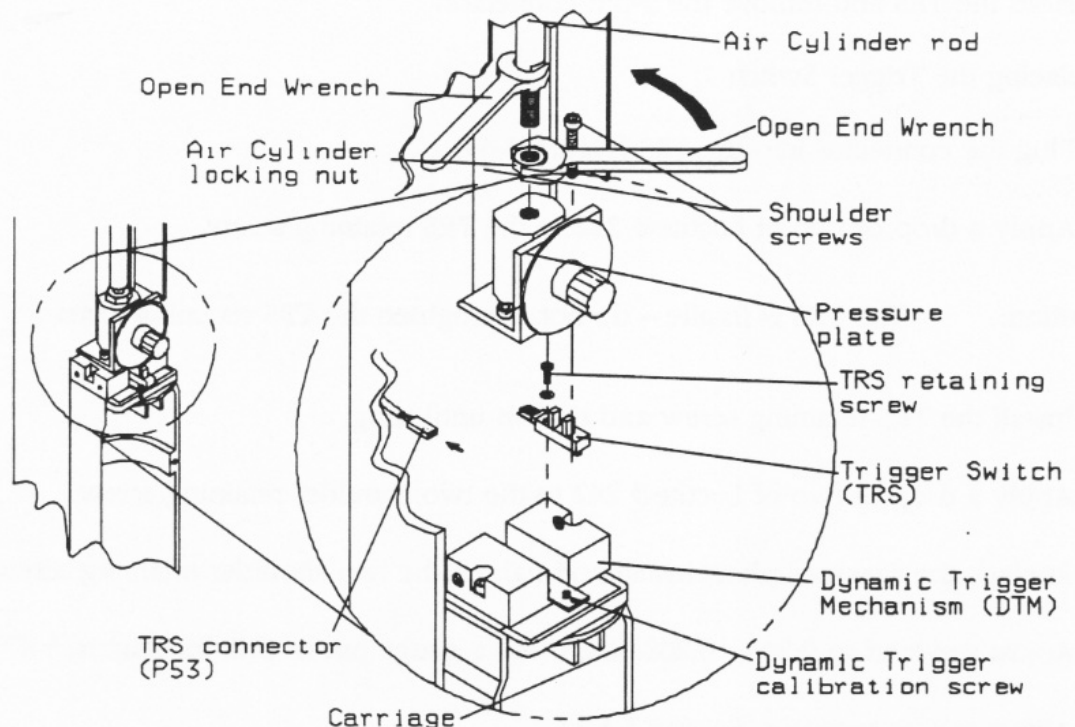

### 5.5.15.1 Removing the Trigger Switch (TRS)

1. Turn off the welder and unplug main power.
2. Turn air pressure to zero, then disconnect main air supply.

WARNING	General Warning
	<p>Turn air pressure to zero and disconnect the main air supply. Failure to do this leave the welder under potentially dangerous air pressure.</p>

3. Open the left side cover. See [5.3 Opening and Removing the Left Side Cover \(EDP 100-032-338\)](#).
4. Remove the Trigger Guard (Section [5.5.9.1 Removing the Trigger Guard](#)).
5. Remove the two shoulder retaining screws holding the pressure plate to the Dynamic Trigger Mechanism lower housing ([Figure 5.32 Removing the Trigger Switch \(TRS\)](#)).
6. Raise the pressure plate on the end of the Air Cylinder rod ([Figure 5.32 Removing the Trigger Switch \(TRS\)](#)).
7. Remove the TRS retaining screw ([Figure 5.32 Removing the Trigger Switch \(TRS\)](#)).
8. Hold the TRS and remove the 3-pin connector.

### 5.5.15.2 Replacing the Trigger Switch

1. Plug the connector into the TRS ([Figure 5.32 Removing the Trigger Switch \(TRS\)](#)).
2. Apply a drop or two of Loctite® 242 to the TRS retaining screw.

CAUTION	General Warning
	<p>The TRS is fragile - do not overtighten the retaining screw.</p>

3. Install the TRS retaining screw and tighten until snug.
4. Apply a drop or two of Loctite® to the two shoulder retaining screws.
5. Replace the pressure plate; install and tighten the two shoulder retaining screws.
6. Adjust pre-load to 0.203 - 0.208 lbs. using a gauge pin or drill bit.
7. Calibrate the TRIGGER PRESSURE. (For instructions on doing this, contact Branson Product Support.)
8. Install the Trigger Guard (Section [5.5.9.2 Replacing the Trigger Guard](#)).
9. Connect the main air supply.
10. Close the left side cover. See [5.3 Opening and Removing the Left Side Cover \(EDP 100-032-338\)](#).

### 5.5.16 Linear Optical Encoder (EDP 100-143-052, IW+ only)

WARNING	General Warning
	<p>Before servicing the welder, make sure to do the following:</p> <ol style="list-style-type: none"> <li>1. Turn off the welder and unplug main power.</li> <li>2. Turn air pressure to zero and disconnect your main air line connection. Failure to do this leaves the welder under potentially dangerous air pressure.</li> <li>3. Wait approximately 5 minutes after unplugging the welder before touching internal electrical components.</li> </ol>

**Figure 5.33** Removing the Linear Optical Encoder (IW+ Only)

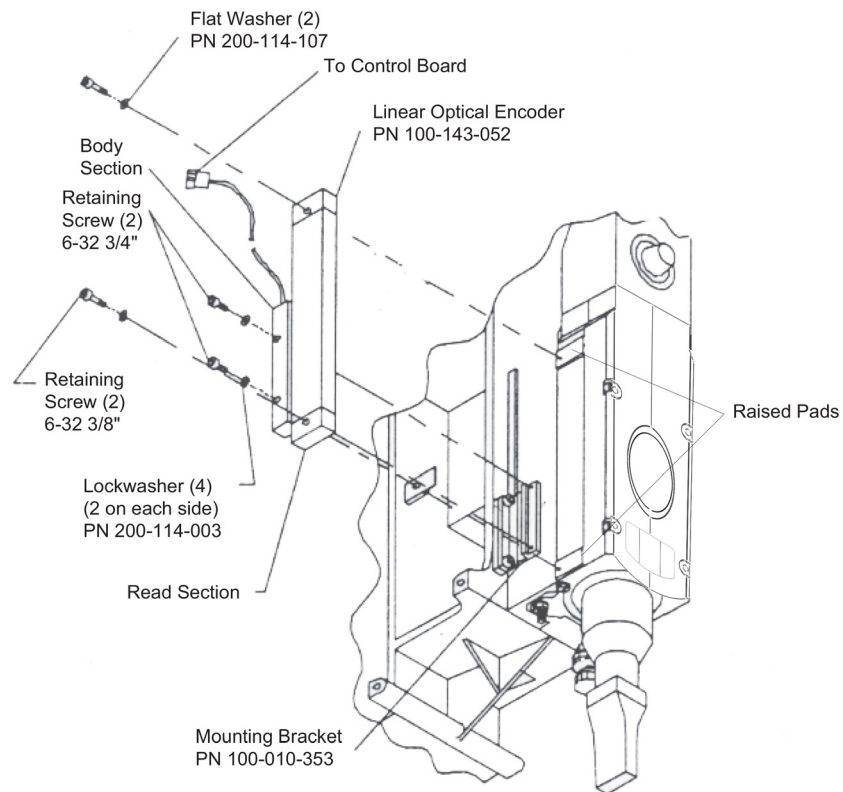

### 5.5.16.1 Removing the Linear Optical Encoder

1. Turn off the welder and unplug main power.
2. Turn air pressure to zero, then disconnect main air supply.

WARNING	General Warning
	<p>Turn air pressure to zero and disconnect the main air supply. Failure to do this leave the welder under potentially dangerous air pressure.</p>

3. Open the left side cover. See [5.3 Opening and Removing the Left Side Cover \(EDP 100-032-338\)](#).
4. Carefully cut the tie wraps attaching the encoder cable to the Main Harness.

CAUTION	General Warning
	<p>Note the number and location of the tie wraps.</p>

Unplug the encoder connector from the Controller Board. (When unplugging, hold the plug - not the cable.)

Hold the encoder in place; then remove the four retaining screws and washers ([Figure 5.33 Removing the Linear Optical Encoder \(IW+ Only\)](#)).

NOTICE	
	<p>Keep track of the retaining screws: short screws for the Read section; long screws for the Body section.</p>

## 5.5.17 Replacing the Linear Optical Encoder

To install the replacements encoder you need the following:

- Loctite® 222 (or equivalent); apply one or two drops to all four retaining screws.
  - An accurate torque wrench
1. Mount the replacement encoder onto the carriage:
  - install the two long screws through the Body section ([Figure 5.33 Removing the Linear Optical Encoder \(IW+ Only\)](#)); and tighten the screws a few turns
  2. Insert the top retaining screw and washer; tighten the screw a few turns
  3. Hold the encoder against the mounting bracket ([Figure 5.33 Removing the Linear Optical Encoder \(IW+ Only\)](#)) and insert the retaining screw and washer. Tighten the screw a few turns
  4. Use a torque wrench to tighten all four retaining screws to a force of 18 in-lbs. Do not overtighten the screws

**Figure 5.34** Shipping Spacers

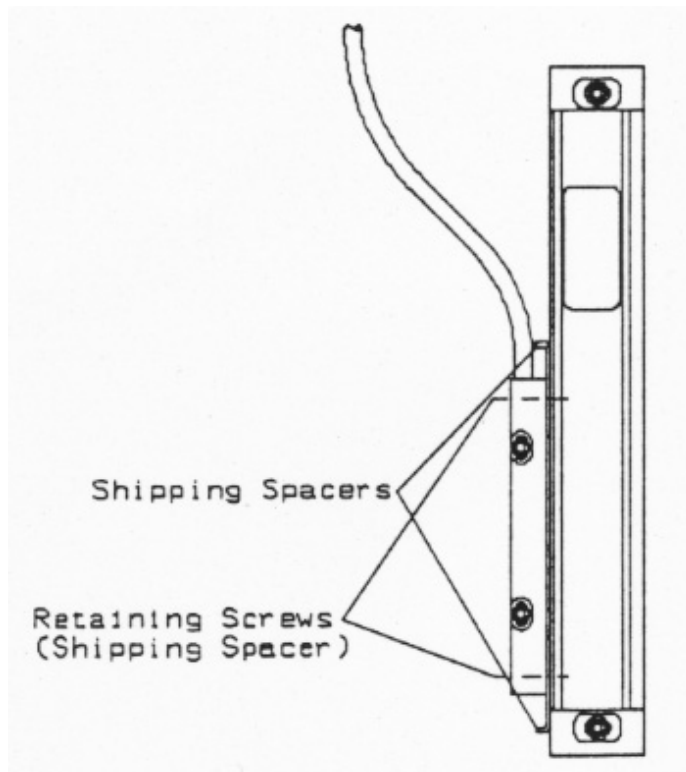

5. Use an Allen wrench to remove the two shipping spacer retaining screws ([Figure 5.34 Shipping Spacers](#))
6. Plug the encoder cable connector into socket J42 on the Control Module
7. Install tie wraps to attach the encoder cable to the Main Harness

CAUTION	General Warning
	<p>Make sure you install enough tie wraps so the encoder cable does not get pinched by carriage movement.</p>

8. Close the left side cover. See [5.3 Opening and Removing the Left Side Cover \(EDP 100-032-338\)](#).
9. Install the two shipping spacers on the faulty encoder. Install each shipping spacer as follows:
  - Insert a retaining screw through the Body section ([Figure 5.34 Shipping Spacers](#))
  - Insert the shipping spacer between the sections ([Figure 5.34 Shipping Spacers](#))
  - While pushing down on the screw; slide the Read section until the screw catches in the shipping spacer hole; and tighten the screw
10. Return the failed encoder to Branson's repair department



---

## **Chapter 6: Repair**

---

**6.1 Periodic Maintenance Procedures ..... 120**

## 6.1 Periodic Maintenance Procedures

The following procedures help assure long term operation of your Branson 2000 Series equipment.

WARNING	General Warning
	<p>Use LOTO (Lock Out Tag Out) lockable plug cover over line cord plug during any maintenance.</p>

Periodic maintenance for the welder involves:

- Inspecting the mating surfaces of the Converter-Booster-Horn Stack. If these surfaces become corroded, recondition the surfaces by following the instructions in Section [6.1.1 Reconditioning the Stack \(Converter, Booster and Horn\)](#)
- Inspecting and cleaning Air Filter components
- External covers may be cleaned with a damp sponge or cloth using a solution of mild soap and water. Do not allow cleaning solution to enter the unit
- Manually tuning the welder after removing or replacing stack components: Converter, Booster, or Stack

### 6.1.1 Reconditioning the Stack (Converter, Booster and Horn)

Welding system components work most efficiently when the Converter-Booster-Horn Stack mating surfaces are flat, in solid contact, and free from fretting corrosion. Poor contact between mating surfaces wastes power output, makes tuning difficult, increases noise and heat, and may cause damage to the converter.

For standard 20 kHz products, a Branson Mylar® washer should be installed between the horn and booster, and horn and converter. Replace the washer if torn or perforated. Stacks using Mylar washers should be inspected every three months.

CAUTION	General Warning
	<p>Never clean the Converter-Booster-Horn Stack mating surfaces by using a buffing wheel or by filing.</p>

WARNING	General Warning
	<p>When performing maintenance on the welder, make sure that no other automated systems are active.</p>

### 6.1.1.1 Stack Reconditioning Procedure

To recondition stack mating surfaces, take the following steps:

**Table 6.1** Stack Reconditioning Procedure

Step	Action
1	Disassemble the Converter-Booster-Horn Stack and wipe the mating surfaces with a clean cloth or paper towel.
2	Examine all mating surfaces. If any mating surface shows corrosion or a hard, dark deposit, recondition it.
3	If necessary, remove the threaded stud from the part.
4	Tape a clean sheet of #400 (or finer) grit emery cloth to a clean, smooth, flat surface (such as a sheet of plate glass), as in <a href="#">Figure 6.1 Reconditioning Stack Surfaces</a> .
5	Place the interface surface on the emery cloth. Grasp the part at the lower end, with your thumb over the spanner-wrench hole, and lap the part in a straight line across the emery cloth. Do not apply downward pressure - the weight of the part alone provides sufficient pressure.
<p><b>CAUTION</b></p> <p>Use extreme care to avoid tilting the part and losing flatness of the surface. Doing so may make the system inoperable - due to improper mating surfaces.</p>	
6	Lap the part, two or three times, in the same direction against the emery cloth. See <a href="#">Figure 6.1 Reconditioning Stack Surfaces</a> .
7	Rotate the part 120 degrees, placing your thumb over the spanner-wrench hole, and repeat the lapping procedure in step 6.
8	Rotate the part another 120 degrees to the next spanner-wrench hole, and repeat the lapping procedure in step 6.
9	Re-examine the mating surface. If necessary, repeat steps 2-5 until you remove most of the contaminant. Remember, this should not require more than two or three complete rotations for an aluminum horn or booster, a titanium component may require more rotations.
10	<p>Before re-inserting a threaded stud in an aluminum booster or horn:</p> <ul style="list-style-type: none"> <li>• Using a file card or wire brush, clean any aluminum bits from the knurled end of the stud</li> <li>• Using a clean cloth or towel, clean the threaded hole</li> <li>• Examine the knurled end of the stud. If worn, replace the stud. Also, examine the stud and threaded hole for stripped threads</li> </ul>
<p><b>CAUTION</b></p> <p>Threaded studs cannot be reused in titanium horns or boosters. Replace all studs in these components.</p>	
11	Assemble and install the stack, referring to Chapter 4 of your 2000IW/IW+ Operating Manual.

**Figure 6.1** Reconditioning Stack Surfaces

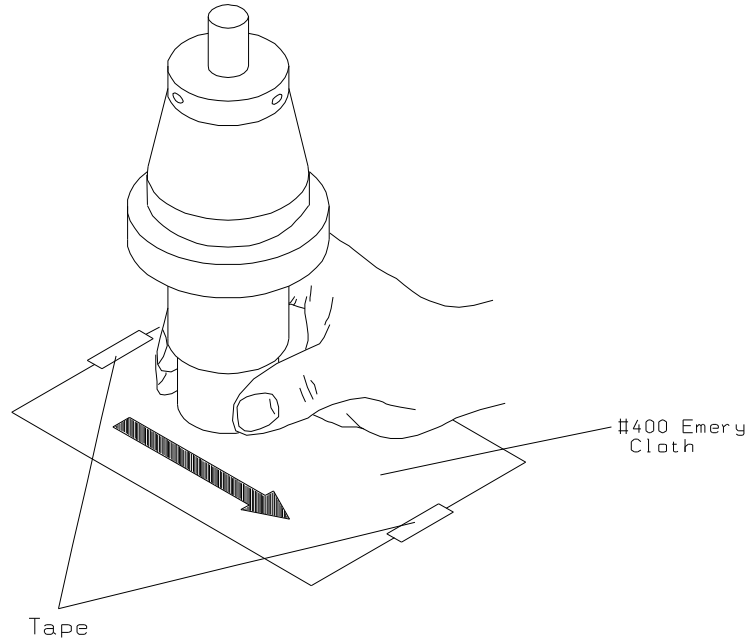

**Table 6.2** Stud Torque Specifications

Frequency	Stud Size	Torque	Part Number
20 kHz	3/8-24 x 1 in.	290 in lbs/33 Nm	100-098-120
20 kHz	3/8-24 x 1-1/4 in.	290 in lbs/33 Nm	100-098-121
20 kHz	1/2-20 x 1-1/4 in.	450 in lbs/47 Nm	100-098-370
20 kHz	1/2-20 x 1-1/2 in.	450 in lbs/47 Nm	100-098-123

**Table 6.3** Booster Interface Torque Specifications

Booster Application	Torque
20 kHz	220 in lbs/25 Nm

**Table 6.4** Tip Interface Specifications

Tip Thread	Torque
1/4-28	110 in lbs/12.42 Nm
3/8-24	180 in lbs/20.33 Nm

## 6.1.2 Routine Component Replacement

The lifetime of certain parts is based on the number of cycles the unit has completed, or on hours of operation. [Table 6.5](#) lists the average number of hours or cycles one should use in determining when components should be replaced. Ambient operating temperature also affects lifetime. Higher temperatures reduce the number of cycles and hours before replacement is suggested. The charts below are for equipment operating at a temperature of 72 to 75° F (22 - 24° C).

The lifetime of system pneumatic components is influenced by the quality of the compressed air provided. All Branson systems require clean, dry, (normal) factory

compressed air. When oil or moisture is present in the compressed air, the lifetime of the pneumatic components will be reduced. This table lists pneumatic parts with an average factory compressed air condition.

**Table 6.5** Component Replacements Based on Cycles Run

Number of Cycles	Component
At 10 Million Cycles	Air Cylinder
At 20 Million Cycles	Base Palm Buttons
	Solenoid Valves
At 40 Million Cycles	Pressure Regulator
	Air Filter
	Encoder Assembly
	Linear Bearing (2" stroke or greater)

**For Reference Purposes:**

1. A system operating at 60 welds per minute, 8 hours per day, 5 days per week, 50 weeks per year completes approximately 7.2 million cycles in 2000 hours.
2. The same system at 24 hours per day, 5 days per week, in 50 weeks completes 21.6 million cycles in 6000 hours.
3. 24 hours per day, 365 days per year produces 31.5 million cycles in 8760 hours.

Please note that parts replaced during preventive maintenance constitute normal wear and tear. They are not covered by warranty.

NOTICE	
	<p>Integrated Welders cycling with less than a 2" stroke can increase the life by exercising the Integrated Welder for 20 or more cycles at full stroke. This should be done every 10 thousand cycles of operation.</p>

### 6.1.3 Servicing the Air Filter (Part No. 200-163-009)

The Air Filter is self-draining. If contaminants build up inside the Air Filter, you can bleed the filter by turning the brass nut on the bottom. If your Air Filter leaks or gets dirty, follow the instructions below.

**Figure 6.2** Disassembly of Air Filter Components

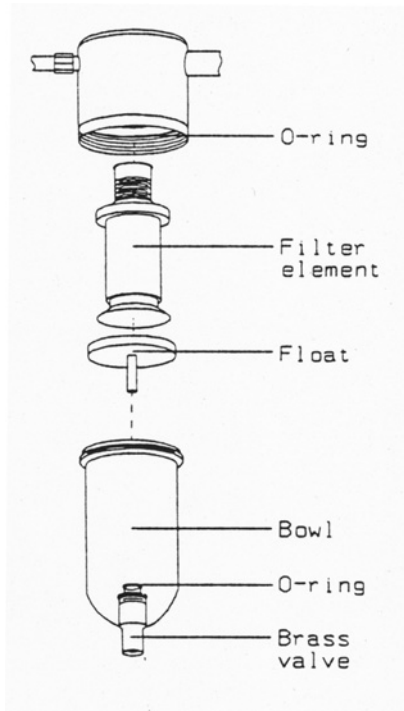

1. Turn air pressure to zero and disconnect the main air supply.

WARNING	General Warning
	<p>Turn air pressure to zero and disconnect the air line connection. Failure to do this leaves the welder under potentially dangerous air pressure.</p>

2. Unscrew the bowl from the housing
3. Unscrew the filter element from the housing
4. Remove the float from the bowl

WARNING	General Warning
	<p>Clean the bowl with household soap only. Never clean the bowl with a solvent.</p>

5. Clean the inside of the bowl with household soap
6. Inspect the O-rings. If the Air Filter leaks, check both O-rings. If one or both of the O-rings is bad, replace the Air Filter
7. Clean the float and filter element
8. Reassemble the Air Filter as follows:

- Place the float into the bowl ([Figure 6.2 Disassembly of Air Filter Components](#))
- Screw the filter element into the housing until finger-tight
- Screw the bowl into the housing

#### 6.1.4 Manual Tuning

NOTICE	
	<p>This should NOT be a regularly performed procedure, but should be used only as a last resort.</p>

If there is an instance where Autotune does not provide proper tuning, using the following procedure.

Remove the Autotune label from the Front Panel.

CAUTION	General Warning
	<p>Do not force the potentiometer beyond its stop limits. The total rotation from full cw to full ccw is only 270°.</p>

**Figure 6.3** Manual Adjustment Procedure Flowchart

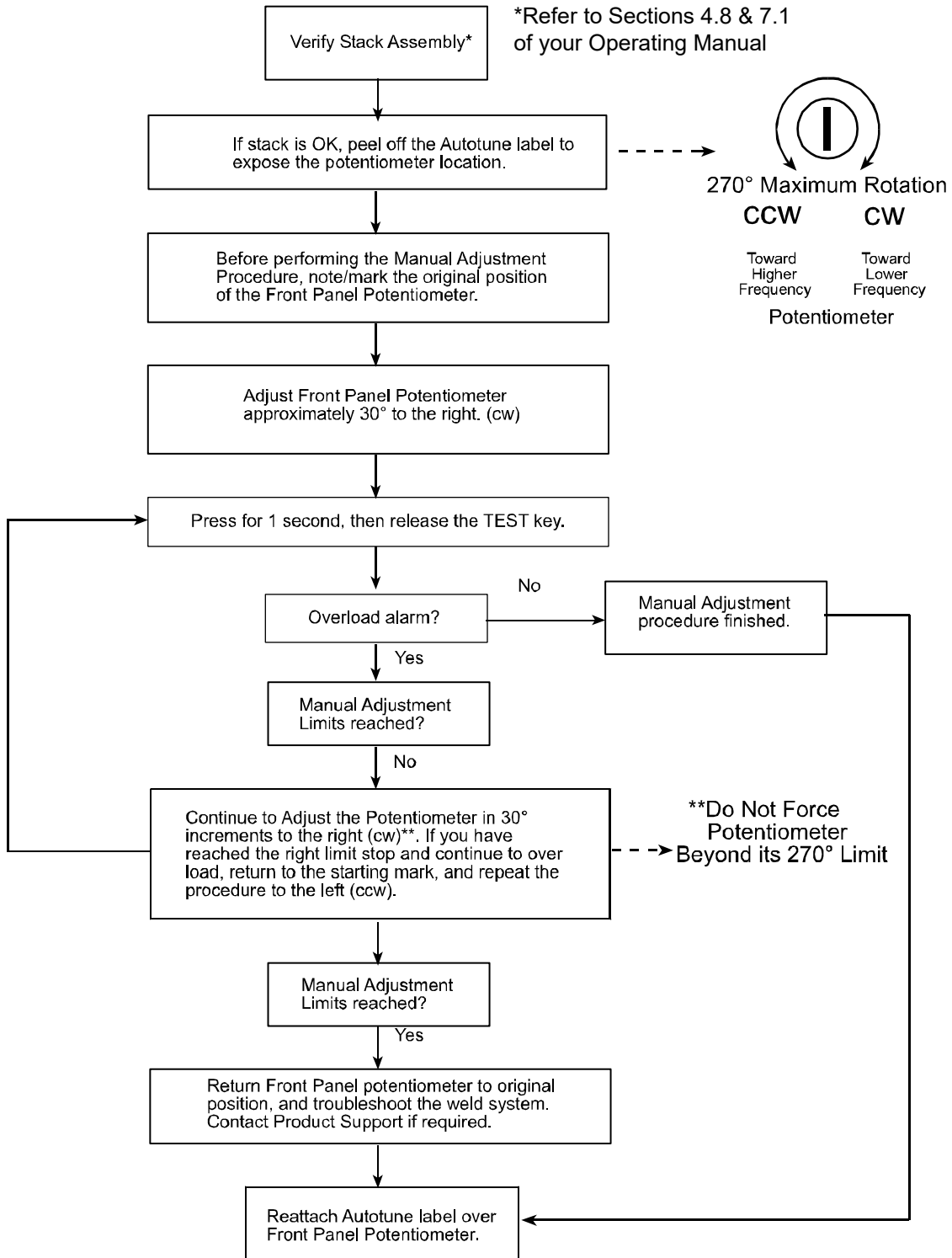

---

## **Chapter 7: Master Parts List**

---

**7.1 Parts Lists. . . . . 128**

## 7.1 Parts Lists

For specific assembly parts, refer to the respective Remove/Replace assembly in [Chapter 5: Assembly/Disassembly](#).

**Table 7.1** Replacement Parts

Description	Part Number
Fuse, 3/4 Amp	200-049-089R
Circuit Breaker, 8 A	200-167-014R
Circuit Breaker, 17A	200-167-015R
Membrane Keypad 2000 IW	100-242-560
Membrane Keypad 2000 IW+	100-242-561
AC/DC Universal Supply	200-132-777R
PC BD Line IW UPS	100-242-546R
PC BD Display IW	100-242-1201R
PC BD Display IW+	100-242-1202R
2000 IW/IW+ Operating Manual	1019568
2000 IW/IW+ Maintenance Manual	1019567
Kit, Accessory Input/Output Connection	101-063-721
Kit, Controller 2000 IW and IW+	101-063-718
Kit, Fan	101-063-722
Kit, Linear Encoder with Installation Instructions	101-063-553
Kit, Power Module 2.2 kW, 2000 IW	101-063-720
Kit, Power Module 1.1 kW, 2000 IW	101-063-719
IW+ 3.3kW Spare Part Kit	BU-1038596
IW+ 1.1kW@110V / 2.2kW @220V Spare Part Kit	BU-1038597
IW+ 1.1kW@220V Spare Part Kit	BU-1038598

---

# Index

---

## **Numerics**

2000IW/IW+ Boosters 46

## **A**

Adjusting the Mechanical Stop 103  
Air Cylinder 104  
Air Cylinder Part Numbers 104  
Air filter 43  
Air Lines, Connecting and Disconnecting 66  
Alarm Codes and Error Messages 57  
Assembly/Disassembly 64

## **B**

Box Fan 74  
Branson  
    how to contact 8

## **C**

Carriage and Slide System 16  
Carriage Return Spring 109  
Circuit Breaker, On Off Switch 76  
Circuit Descriptions 36  
Column Clamps and Elevator Knob 81  
Compatibility with Branson Products 18  
Control Module 87  
Controller 16  
Controller board 87  
Converter-Booster-Horn Stack 100  
Converters and Boosters 46

## **D**

DC Power Module 41  
Disclaimer of Warranty 7  
Display board 87  
Down Speed Control Valve 96  
Dynamic Trigger Mechanism 106  
Dynamic Triggering and Follow-Through 17

## **E**

Emissions 6  
EXTERNAL RESET - ALARM Connector 29

## **F**

Factory Air Supply  
    clean Specs 43  
    maximum pressure 43  
Features 19

Front Panel Controls 20

## **G**

GENERAL ALARM - Alarm Connector 29  
Glossary 31

## **H**

How to contact Branson 8

## **I**

In-line air filter 43

## **K**

Keypad 90  
Kit 47

## **L**

Line Board 36, 78  
Linear Optical Encoder 16  
Linear Optical Encoder, IW+ only 114

## **M**

Main Assembly 69  
Main Assembly Components 64  
Main Assembly Components (Left Side View) 70  
Main Assembly Components (Right Side View) 71  
Main Support Assembly 64, 97  
Main Support Assembly, Front View 98  
Main Support Assembly, Side View 99  
Mylar® Washers 47

## **N**

Nose Assembly 64, 84

## **O**

Other items used with the 2000IW/IW+ 47  
Output Circuit 39  
Overview of these Models 15

## **P**

Parts Lists 128  
Periodic and Preventive Maintenance  
  Routine Component Replacement 122  
Physical Description 34  
Pneumatic Requirements 43  
Pneumatic System 16  
Power Supply 16  
Power Supply, AC/DC Universal, 24V In, 5V Out 74  
Pressure Gauge 94  
Pressure Regulator 92  
PVC Materials 6

**R**

READY Signal - ALARM Connector 29  
Rear Panel 27  
Regulatory Compliance 6  
Remove 24/5 Volt Power Supply and Box Fan 75  
Remove and Replace Circuit Breaker, On Off Switch 76  
Removing a Column Clamp 82  
Removing the Air Cylinder 105  
Removing the Carriage Return Spring 110  
Removing the Controller Board 88  
Removing the Converter-Booster-Horn Stack 100  
Removing the Down Speed Control Valve 96  
Removing the Dynamic Trigger Mechanism 107  
Removing the Elevator Knob 83  
Removing the Keypad 90  
Removing the Left Side Cover 67  
Removing the Line Board 78  
Removing the Linear Optical Encoder 115  
Removing the Pressure Gauge 95  
Removing the Pressure Regulator 92  
Removing the RF Contact Block 108  
Removing the Trigger Guard 102  
Removing the Trigger Switch (TRS) 113  
Removing the Ultrasonic Power Supply Module 73  
Removing the Upper Limit Switch (ULS) 112  
Replacing a Column Clamp 82  
Replacing the Air Cylinder 106  
Replacing the Carriage Return Spring 111  
Replacing the Converter-Booster-Horn Stack 101  
Replacing the Down Speed Control Valve 97  
Replacing the Dynamic Trigger Mechanism 108  
Replacing the Elevator Knob 83  
Replacing the Keypad 91  
Replacing the Left Side Cover 68  
Replacing the Line Board 79  
Replacing the Linear Optical Encoder 116  
Replacing the Nose Assembly 86  
Replacing the Pressure Gauge 95  
Replacing the Pressure Regulator 93  
Replacing the Programmer Module 89  
Replacing the RF Contact Block 109  
Replacing the Trigger Guard 103  
Replacing the Trigger Switch 114  
Replacing the Ultrasonic Power Supply Module 73  
Replacing the Upper Limit Switch 112  
Returning Equipment for Repair 9  
RF Contact Block 108

**S**

Safety  
PVC Materials 6  
Shipping and Handling 34  
Shipping Spacers 116  
Solenoid Valve (SV) 79  
START SWITCHES/START Signal - START Connector 29  
Studs 47

System Control Board 37  
System Inputs/Outputs 29

## **T**

Trigger Guard 101  
Trigger Switch (TRS) 113

## **U**

Ultrasonic Power Module  
  Main Circuits 39  
Ultrasonic Power Supply Module 71  
Upper Limit Switch 17, 111  
User I/O 29, 41  
User I/O Connector 17

## **W**

Warranty 7  
WELD ON Signal - Alarm Connector 30