

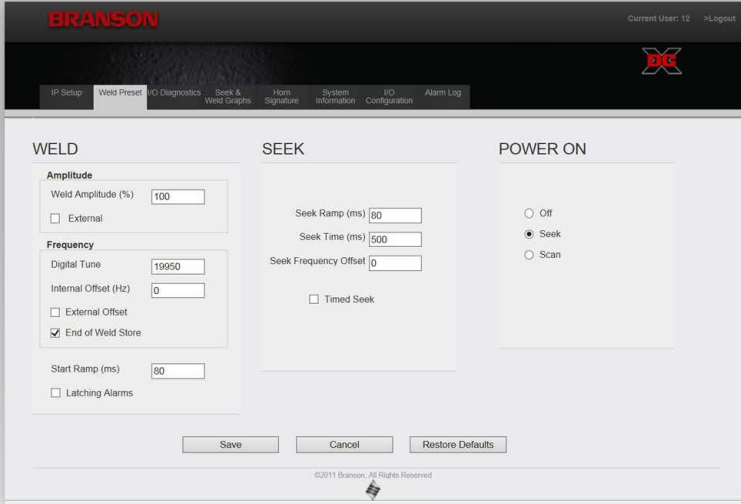

EMERSONTM

**Original Instructions
4000843 - REV. 03**



DCX Power Supply

Web Page Interface

Operating Manual

Branson Ultrasonics Corp.
120 Park Ridge Road
Brookfield, CT 06804
(203) 796-0400
<http://www.bransonultrasonics.com>

BRANSON

Manual Change Information

At Branson, we strive to maintain our position as the leader in ultrasonics plastics joining, metal welding, cleaning and related technologies by continually improving our circuits and components in our equipment. These improvements are incorporated as soon as they are developed and thoroughly tested.

Information concerning any improvements will be added to the appropriate technical documentation at its next revision and printing. Therefore, when requesting service assistance for specific units, note the Revision information found on this document, and refer to the printing date which appears on this page.

Copyright and Trademark Notice

Copyright © 2026 Branson Ultrasonics Corporation.

All rights reserved.

Contents of this publication may not be reproduced in any form without the written permission of Branson Ultrasonics Corporation.

This product incorporates lwIP TCP IP Stack software under the following Copyright and License:

Copyright © 2001-2004 Swedish Institute of Computer Science.

All rights reserved.

Redistribution and use in source and binary forms, with or without modification, are permitted provided that the following conditions are met:

1. Redistributions of source code must retain the above copyright notice, this list of conditions and the following disclaimer.
2. Redistributions in binary form must reproduce the above copyright notice, this list of conditions and the following disclaimer in the documentation and/or other materials provided with the distribution.
3. The name of the author may not be used to endorse or promote products derived from this software without specific prior written permission.

THIS SOFTWARE IS PROVIDED BY THE AUTHOR "AS IS" AND ANY EXPRESS OR IMPLIED WARRANTIES, INCLUDING, BUT NOT LIMITED TO, THE IMPLIED WARRANTIES OF MERCHANTABILITY AND FITNESS FOR A PARTICULAR PURPOSE ARE DISCLAIMED. IN NO EVENT SHALL THE AUTHOR BE LIABLE FOR ANY DIRECT, INDIRECT, INCIDENTAL, SPECIAL, EXEMPLARY, OR CONSEQUENTIAL DAMAGES (INCLUDING, BUT NOT LIMITED TO, PROCUREMENT OF SUBSTITUTE GOODS OR SERVICES; LOSS OF USE, DATA, OR PROFITS; OR BUSINESS INTERRUPTION) HOWEVER CAUSED AND ON ANY THEORY OF LIABILITY, WHETHER IN CONTRACT, STRICT LIABILITY, OR TORT (INCLUDING NEGLIGENCE OR OTHERWISE) ARISING IN ANY WAY OUT OF THE USE OF THIS SOFTWARE, EVEN IF ADVISED OF THE POSSIBILITY OF SUCH DAMAGE.

Excel, Windows 10, Windows 11, and Microsoft Edge are registered trademarks of Microsoft Corporation.

Google Chrome is a trademark of Google LLC.

Other trademarks and service marks mentioned herein are held by their respective owners.

Foreword

Congratulations on your choice of a Branson Ultrasonics Corporation system!

The Branson DCX Series systems are process equipment for the joining of plastic parts using ultrasonic energy. They are the newest generation of products using this sophisticated technology for a variety of customer applications. This Operating Manual is part of the documentation set for these systems, and should be kept with your equipment.

Thank you for choosing Branson!

Introduction

This manual is arranged into several structured chapters which will help you find the information you may need to know to use the DCX Web Page Interface. Please refer to the [Table Of Contents](#) and/or the [Index](#) of this manual to find the information you may be looking for. In the event you require additional information, please refer to your power supply manual. For additional assistance, contact our Product Support department (see [1.3 How to Contact Branson](#) for information on how to contact them) or your local Branson representative.



Table Of Contents

Chapter 1: Safety and Support

1.1	Safety Requirements and Warnings	2
1.2	General Precautions	3
1.3	How to Contact Branson	6

Chapter 2: The Web Page Interface

2.1	Introduction	8
2.2	Models Covered	9

Chapter 3: Connecting to the Web Page Interface

3.1	Locating the Ethernet Port	12
3.2	System Requirements	13
3.3	Point to Point Connection (Windows 10 or Windows 11)	14

Chapter 4: Using the Web Page Interface

4.1	Web Page Interface Overview	18
4.2	Login	19
4.3	IP Setup	20
4.4	Weld Preset	22
4.5	I/O Diagnostics	24
4.6	Seek & Weld Graphs	26
4.7	Horn Signature	29
4.8	System Information	31
4.9	I/O Configuration	32
4.10	Alarm Log	35

Appendix A: Information on Ultrasonic Welding

A.1	Introduction	40
A.2	Resonance	41
A.3	The Principle and the Components of Ultrasonic Welding	42
A.4	Resonance Analysis	45
A.5	Graphics of a Weld	49
A.6	DCX Alarms Table	54

Appendix B: Manual's Revisions

B.1	Manual's Revisions	58
-----	------------------------------	----



List Of Figures

Chapter 1: Safety and Support

Chapter 2: The Web Page Interface

Chapter 3: Connecting to the Web Page Interface

Figure 3.1	Ethernet Port Location (DCX S)	12
Figure 3.2	Ethernet Port Location (DCX V)	12

Chapter 4: Using the Web Page Interface

Figure 4.1	Web Page Interface Overview	18
Figure 4.2	Login	19
Figure 4.3	IP Setup Menu	20
Figure 4.4	Weld Preset Menu	22
Figure 4.5	I/O Diagnostics Menu.	24
Figure 4.6	Seek & Weld Graphs Menu	26
Figure 4.7	Horn Signature Menu.	29
Figure 4.8	System Information Menu	31
Figure 4.9	I/O Configuration Menu	32
Figure 4.10	Alarm Log Menu	35

Appendix A: Information on Ultrasonic Welding

Figure A.1	The Components of an US Welding System	42
Figure A.2	Amplitude Transformation Via the Booster	43
Figure A.3	Commonly Used Horn Shapes	44
Figure A.4	Getting Scan Data	45
Figure A.5	Graphics of a scan	46
Figure A.6	Horn Scan, Possible Defective Converter	47
Figure A.7	Horn Scan, Open RF Cable	48
Figure A.8	Getting Weld Data	49
Figure A.9	Graphical Display of the Weld Curves.	50
Figure A.10	Weld Graph, Defective Horn	51
Figure A.11	Weld Graph, Defective Converter	52
Figure A.12	Weld Graph, Open RF Cable	53

Appendix B: Manual's Revisions

Figure B.1	Manufacturing date on the Information label.	58
Figure B.2	Location of the Information label on the back of the DCX V Power Supply Horizontal	59
Figure B.3	Location of the Information label on the top of the DCX V Power Supply Vertical.	59

List Of Tables

Chapter 1: Safety and Support

Chapter 2: The Web Page Interface

Chapter 3: Connecting to the Web Page Interface

Chapter 4: Using the Web Page Interface

Table 4.1	Web Page Interface Overview	18
Table 4.2	IP Setup Menu Options.	20
Table 4.3	Weld Preset Menu Options	22
Table 4.4	I/O Diagnostics Menu Options.	25
Table 4.5	Seek and Weld Graphs Menu Options.	27
Table 4.6	Horn Signature Menu Options	30
Table 4.7	System Information Menu Display	31
Table 4.8	Available Digital Input Functions	33
Table 4.9	Available Digital Output Functions	33
Table 4.10	Available Analog Input Functions.	34
Table 4.11	Available Analog Output Functions.	34
Table 4.12	Alarm Log Menu Display.	36

Appendix A: Information on Ultrasonic Welding

Table A.1	Components of an US Welding System.	42
Table A.2	Commonly Used Horn Shapes	44
Table A.3	DCX Alarms	54

Appendix B: Manual's Revisions

Table B.1	Manual's Revisions	58
-----------	------------------------------	----



Chapter 1: Safety and Support





1.1 Safety Requirements and Warnings 2
1.2 General Precautions 4
1.3 How to Contact Branson 7



1.1 Safety Requirements and Warnings

This chapter contains an explanation of the different safety notice symbols and icons found in this manual and provides additional safety information for ultrasonic welding. This chapter also describes how to contact Branson for assistance.

1.1.1 Symbols Found in this Manual

These symbols used throughout this manual warrant special attention:

WARNING	Indicates a possible danger
	If these risks are not avoided, death or severe injury might result.
WARNING	High Voltage Hazard
	High voltage. Turn power off before servicing.
WARNING	Corrosive Material Hazard
	Corrosive material. Avoid contact with eyes and skin. Wear proper protection.
CAUTION	Indicates a possible danger
	If these risks are not avoided, slight or minor injury might result.

CAUTION	Loud Noise Hazard
	<p>Loud noise hazard. Ear protection must be worn.</p>
CAUTION	Heavy Object
	<p>Heavy object. To avoid muscle strain or back injury, use lifting aids and proper lifting techniques.</p>
NOTICE	Indicates a possible damaging situation
	<p>If this situation is not avoided, the system or something in its vicinity might get damaged.</p> <p>Application types and other important or useful information are emphasized.</p>

1.2 General Precautions

Take the following precautions before servicing the power supply:

- Be sure the power switch is in the Off position before making any electrical connections
- To prevent the possibility of an electrical shock, always plug the power supply into a grounded power source
- Power supplies produce high voltage. Before working on the power supply assembly, do the following:
 - Turn off the power supply;
 - Unplug main power; and
 - Allow at least 5 minutes for capacitors to discharge
- High voltage is present in the power supply. Do not operate with the cover removed
- High line voltages exist in the ultrasonic power supply assembly. Common points are tied to circuit reference, not chassis ground. Therefore, use only non-grounded, battery-powered multimeters when testing the power supply assembly. Using other types of test equipment can present a shock hazard
- Keep hands from under the horn. Down force (pressure) and ultrasonic vibrations can cause injury
- Do not cycle the welding system if either the RF cable or converter is disconnected
- When using larger horns, avoid situations where fingers could be pinched between the horn and the fixture

CAUTION	Loud Noise Hazard
	<p>Sound level and frequency of the noise emitted during the ultrasonic assembly process may depend upon a. type of application, b. size, shape and composition of the material being assembled, c. shape and material of the holding fixture, d. welder setup parameters and e. tool design. Some parts vibrate at an audible frequency during the process. Some or all of these factors may result in an uncomfortable noise being emitted during the process.</p> <p>In such cases operators may need to be provided with personal protective equipment. See 29 CFR (Code of Federal Regulations) 1910.95 Occupational Noise Exposure.</p>

NOTICE	
	<p>When the battery is worn out, dispose it under the ordinance of each local government.</p>

WARNING	Corrosive Material Hazard
	<p>First aid measures (in case of electrolyte leakage from the battery):</p> <p>Eye Contact: Flush the eyes with plenty of clean water for at least 15 minutes immediately, without rubbing. Get immediate medical treatment.</p> <p>If appropriate procedures are not taken, this may cause eye injury.</p> <p>Skin Contact: Wash the affected area under tepid running water using a mild soap. If appropriate procedures are not taken, this may cause sores on the skin. Get medical attention if irritation develops or persists.</p> <p>Inhalation: Remove to fresh air immediately. Get medical treatment immediately.</p>

1.2.1 Intended Use of the System

The DCX Power Supply and components are designed to be used as part of an ultrasonic welding system. These are designed for a wide variety of welding or processing applications.

The system can be used to perform ultrasonic welding, inserting, staking, spot welding, swaging, degating, and continuous ultrasonic operations. It is designed for automated, semi-automated and/or manual production operations.

1.2.2 Emissions

When being processed, certain plastic materials can emit toxic fumes, gases or other emissions that can be hazardous to the operator's health. Where such materials are processed, proper ventilation of the workstation is required. Check your materials suppliers for recommended protection when processing their materials.

WARNING	Corrosive Material Hazard
	Processing of many materials, such as PVC, can be hazardous to an operator's health and could cause corrosion/damage to the equipment. Use proper ventilation and take protective measures.

1.3 How to Contact Branson

For additional assistance, please refer to the DCX Series Power Supply Instruction Manual.



Chapter 2: The Web Page Interface

2.1	Introduction	8
2.2	Models Covered	9

2.1 Introduction

The DCX Power Supply Web Page Interface provides access, via Ethernet connection, to web pages containing power supply information, diagnostics tools, and configuration options. Communication can be established point-to-point or through a local area network. On the web page interface you can access:

- [4.1 Web Page Interface Overview](#)
- [4.2 Login](#)
- [4.3 IP Setup](#)
- [4.4 Weld Preset](#)
- [4.5 I/O Diagnostics](#)
- [4.6 Seek & Weld Graphs](#)
- [4.7 Horn Signature](#)
- [4.8 System Information](#)
- [4.9 I/O Configuration](#)
- [4.10 Alarm Log](#)

2.2 Models Covered

This manual applies to the web page interface of DCX S-Series and V-Series power supplies.

2.2.1 DCX S-Series and V-Series Manual Set

The following documentation is available in electronic format for the Branson DCX S-Series and V-Series power supplies.

- DCX S-Series Power Supply Instruction Manual
- DCX S-Series Power Supply Quick Start Guide
- DCX V-Series Power Supply Instruction Manual
- DCX V-Series Power Supply Quick Start Guide
- DCX Series Web Page Interface Instruction Manual



Chapter 3: Connecting to the Web Page Interface

3.1	Locating the Ethernet Port	12
3.2	System Requirements	13
3.3	Point to Point Connection (Windows 10 or Windows 11)	14

3.1 Locating the Ethernet Port

Figure 3.1 Ethernet Port Location (DCX S)





Figure 3.2 Ethernet Port Location (DCX V)



3.2 System Requirements

To connect to the DCX Web Page Interface you will need a PC running a Windows^{®1} operating system with an Edge^{®1} or Chrome^{™2} web browser software.

NOTICE	
	The DCX Power Supply is not compatible with network scanning software. If your local network uses these types of programs, the DCX Power Supply IP address must be placed in an exclusion list.

NOTICE	
	A shielded Ethernet cable should be used to connect to the DCX Power Supply Web Page Interface to prevent possible EMI (Electromagnetic Interference) issues.

1. Windows, and Microsoft Edge are registered trademarks of Microsoft Corporation.
2. Google Chrome is a trademark of Google LLC.

3.3 Point to Point Connection (Windows 10[®] or Windows 11[®])

To connect directly to the DCX Power Supply Web Page Interface using a PC with Windows 10[®] or Windows 11[®] operating system, complete the following steps:

1. Connect the power supply to a computer via the Ethernet port
2. Turn on the power supply
3. On your PC, click the Start button on the taskbar and search for the **Control Panel**
4. Select **View Large Icons** on the top right corner
5. Select **Network and Sharing Center**
6. Select **Change adapter settings**

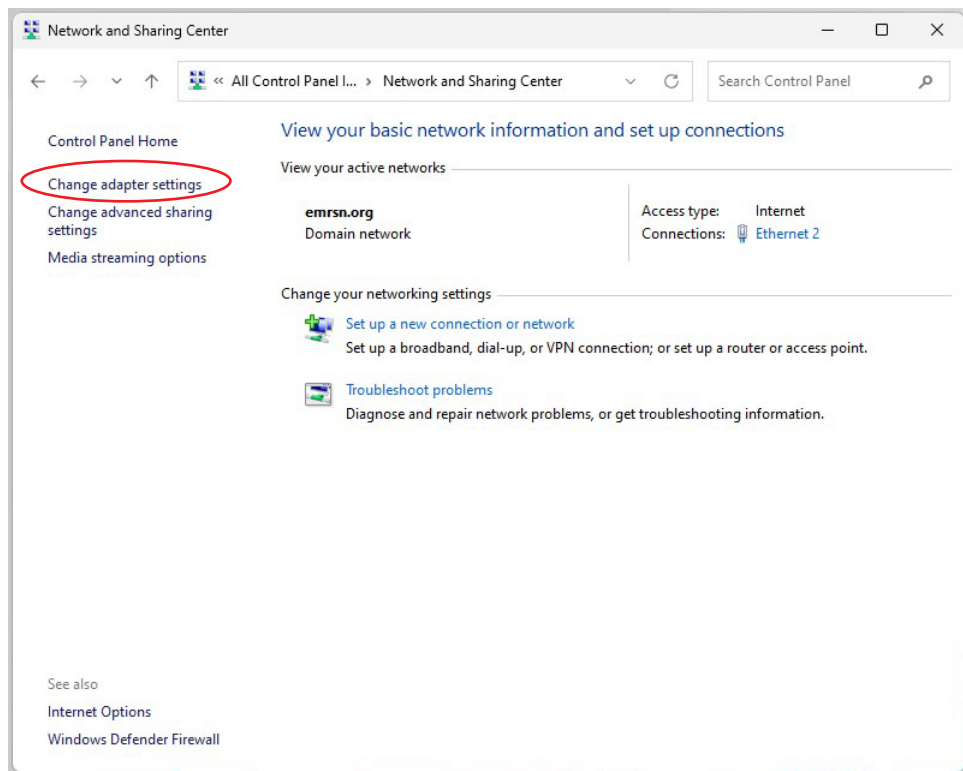

1. Windows 10, and Windows11 are registered trademarks of Microsoft Corporation.

7. Right click on **Ethernet 2** and select **Properties** to bring up the **Networking** tab. You might be prompted to elevate rights to do this change.

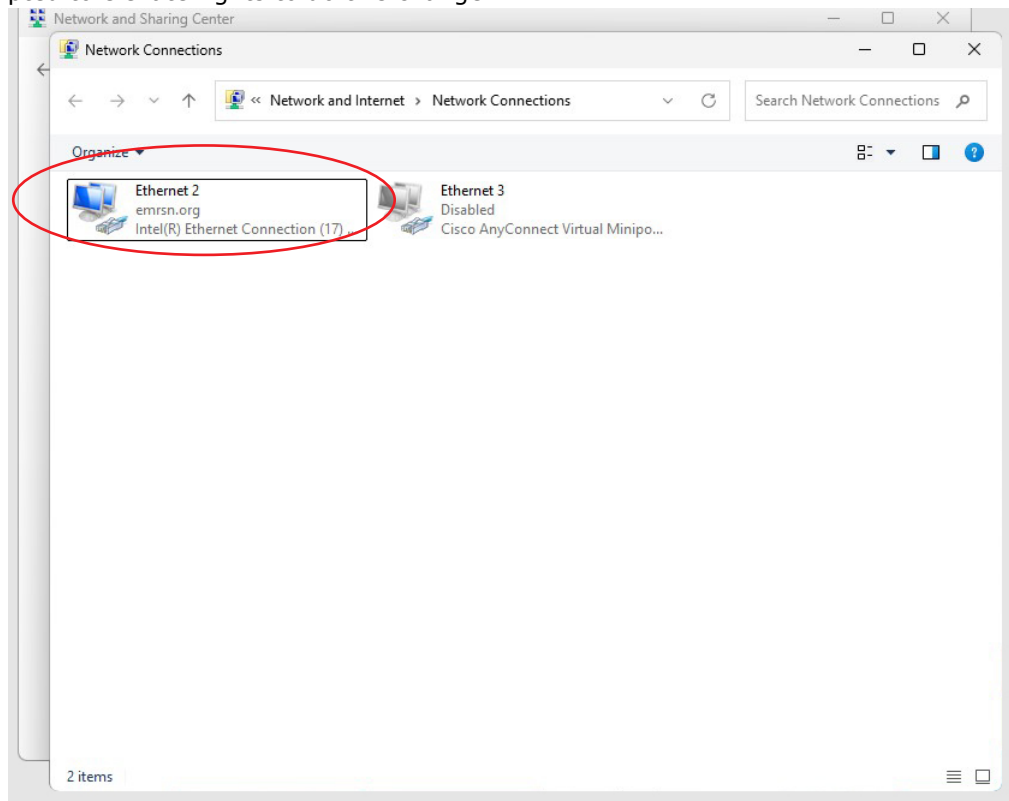

8. Highlight **Internet Protocol Version 4 (TCP/IPv4)** from the list and click on **Properties**.

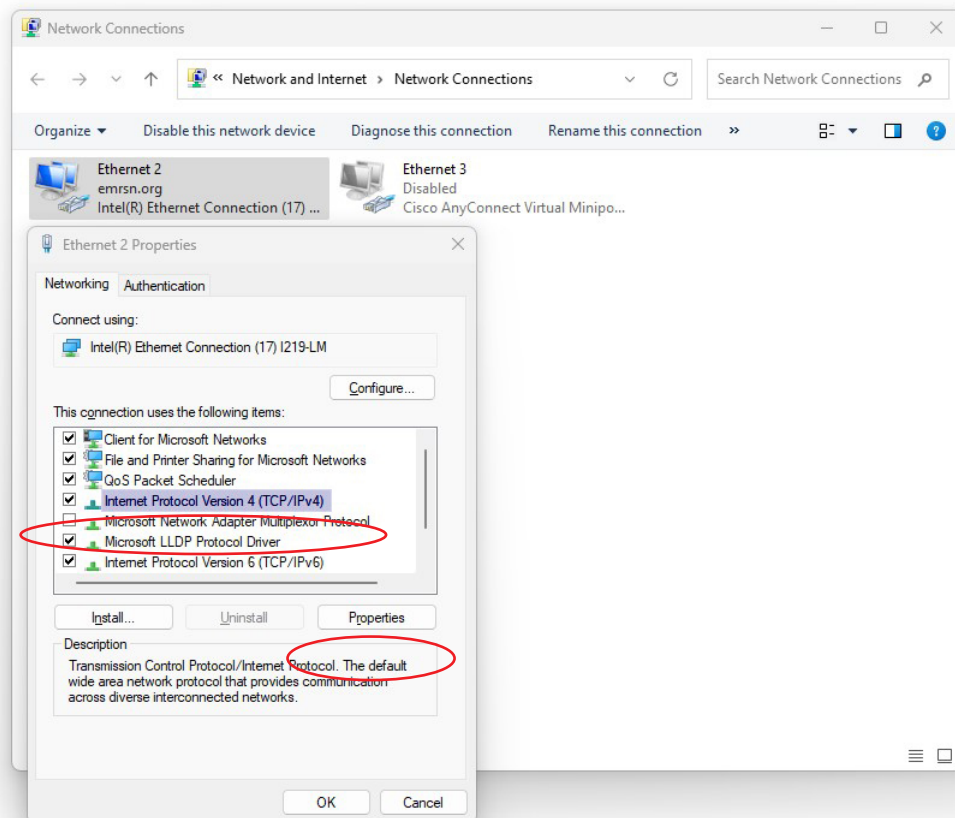

9. Use the following IP address:

IP address: 192.168.10.101

Subnet mask: 255.255.255.0

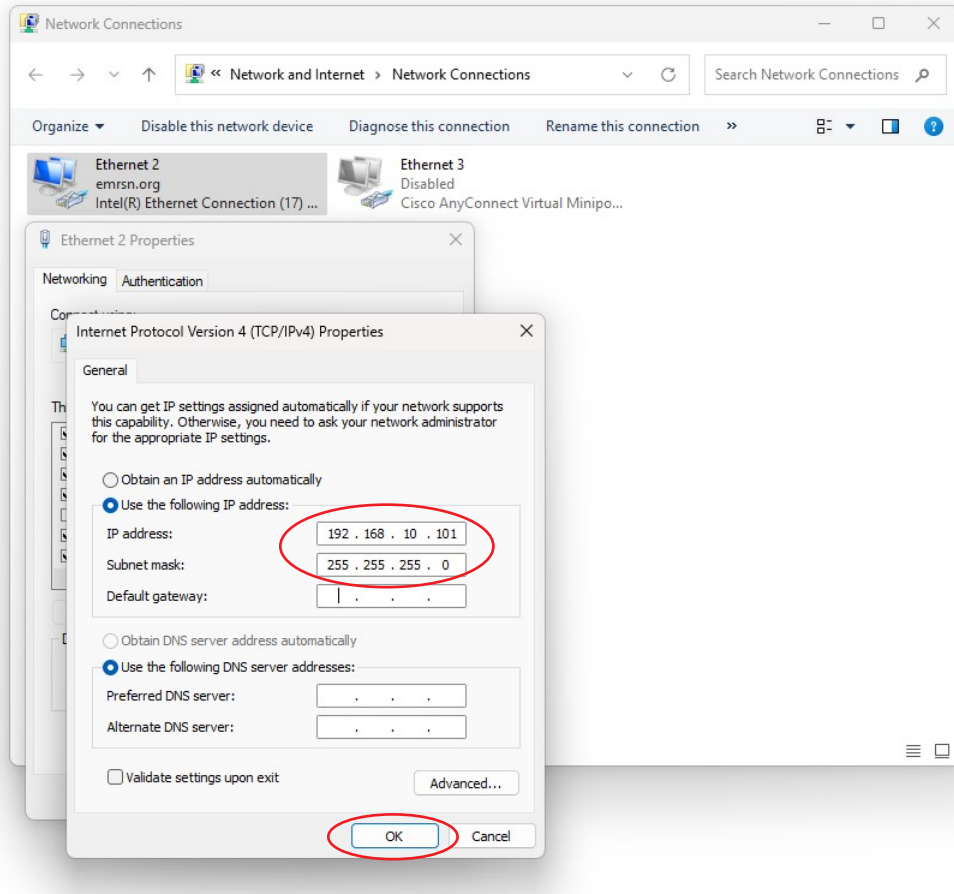

10. Click OK. Close the rest of the dialog boxes

11. Open the Chrome™ or Edge® web browser

12. In the address bar type the following address: <http://192.168.10.100>. Press Enter

13. This will bring up the DCX Web Page Interface

14. Enter an user ID number (any number up to 9 digits long).

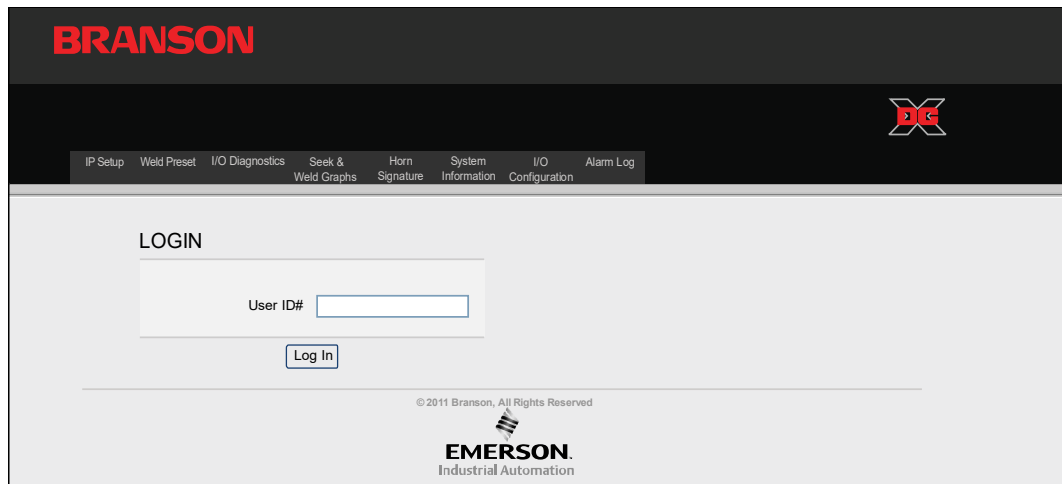

Chapter 4: Using the Web Page Interface

4.1	Web Page Interface Overview	18
4.2	Login	19
4.3	IP Setup	20
4.4	Weld Preset	22
4.5	I/O Diagnostics	24
4.6	Seek & Weld Graphs	26
4.7	Horn Signature	29
4.8	System Information	31
4.9	I/O Configuration	32
4.10	Alarm Log	35

4.1 Web Page Interface Overview

The DCX Power Supply Web Page Interface allows you to set a weld preset, diagnose and configure the power supply I/O, perform horn scans and tests, view system information, and to view and download the system alarm log.

Figure 4.1 Web Page Interface Overview

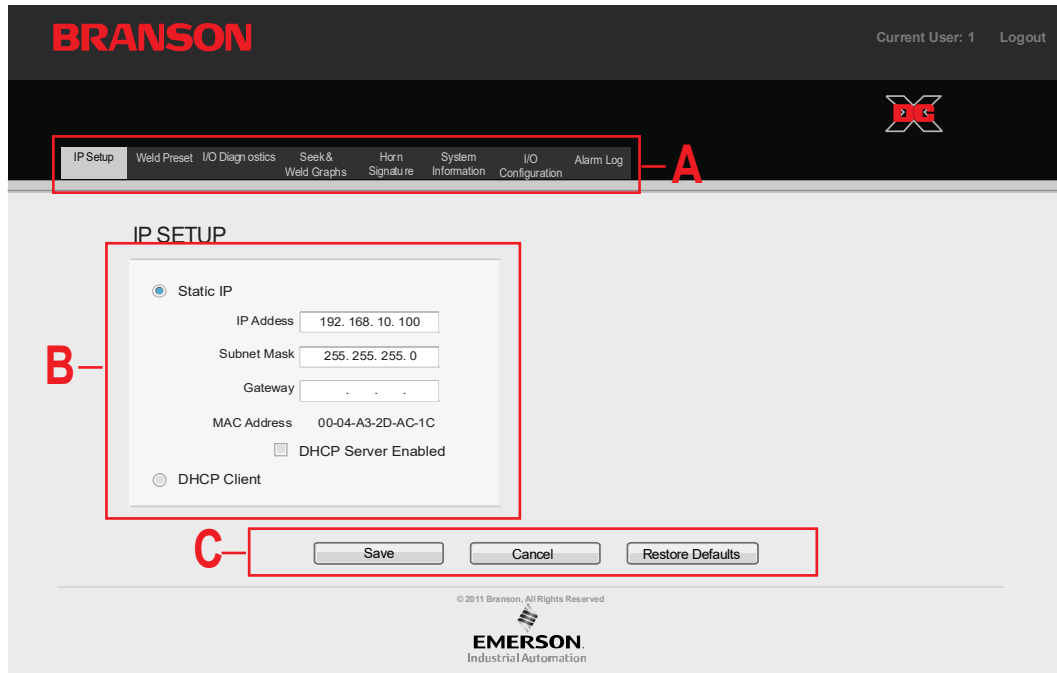

Table 4.1 Web Page Interface Overview

Item	Name	Description
A	Menu Navigation Tabs	The menu navigation tabs are always displayed on the upper section of the web pages. They provide access to the following menu options: <ul style="list-style-type: none"> • 4.3 IP Setup • 4.4 Weld Preset • 4.5 I/O Diagnostics • 4.6 Seek & Weld Graphs • 4.7 Horn Signature • 4.8 System Information • 4.9 I/O Configuration • 4.10 Alarm Log
B	Menu Display	Displays the contents of the currently selected menu option.
C	Command Buttons	Different command buttons allow to save settings, cancel changes, restore default settings, and to perform other functions specific to each menu.

4.2 Login

When connection is established with the DCX Web Page Interface, the Login page will display. Enter a unique user ID number. The user ID is numeric only and up to 9 digits long. This number allows for keeping track of user access.

Figure 4.2 Login

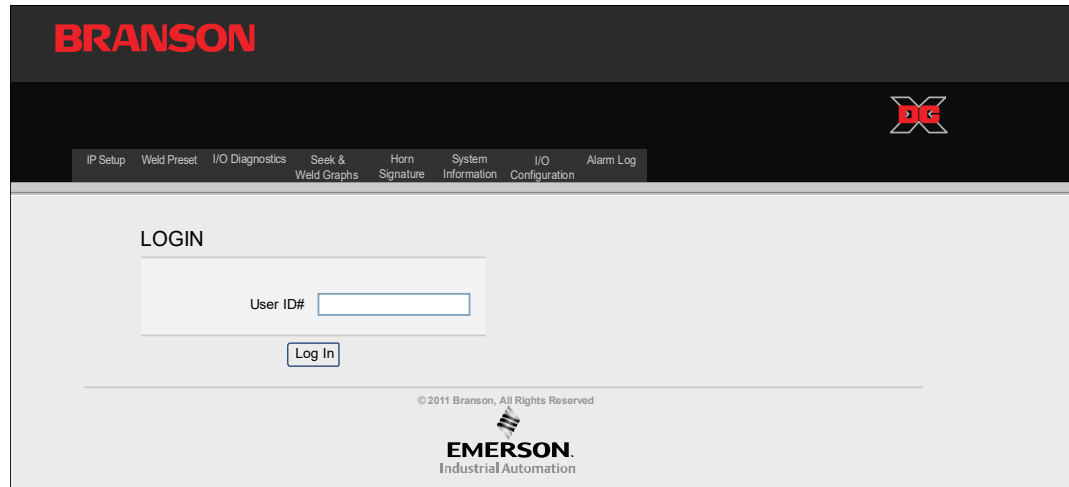

The screenshot shows the login page of the Branson DCX Web Page Interface. The page has a dark header with the "BRANSON" logo in red on the left and the "DCX" logo in red on the right. Below the header is a navigation menu with the following items: IP Setup, Weld Preset, I/O Diagnostics, Seek & Weld Graphs, Horn Signature, System Information, I/O Configuration, and Alarm Log. The main content area is light gray and contains the word "LOGIN" in bold. Below "LOGIN" is a text input field labeled "User ID#" with a small blue border. Below the input field is a "Log In" button. At the bottom of the page, there is a copyright notice: "© 2011 Branson. All Rights Reserved" and the Emerson Industrial Automation logo.

4.3 IP Setup

Use this menu to setup the DCX Power Supply's network settings. The DCX Power Supply's default IP setting is Static IP with the address shown in the figure below.

Figure 4.3 IP Setup Menu

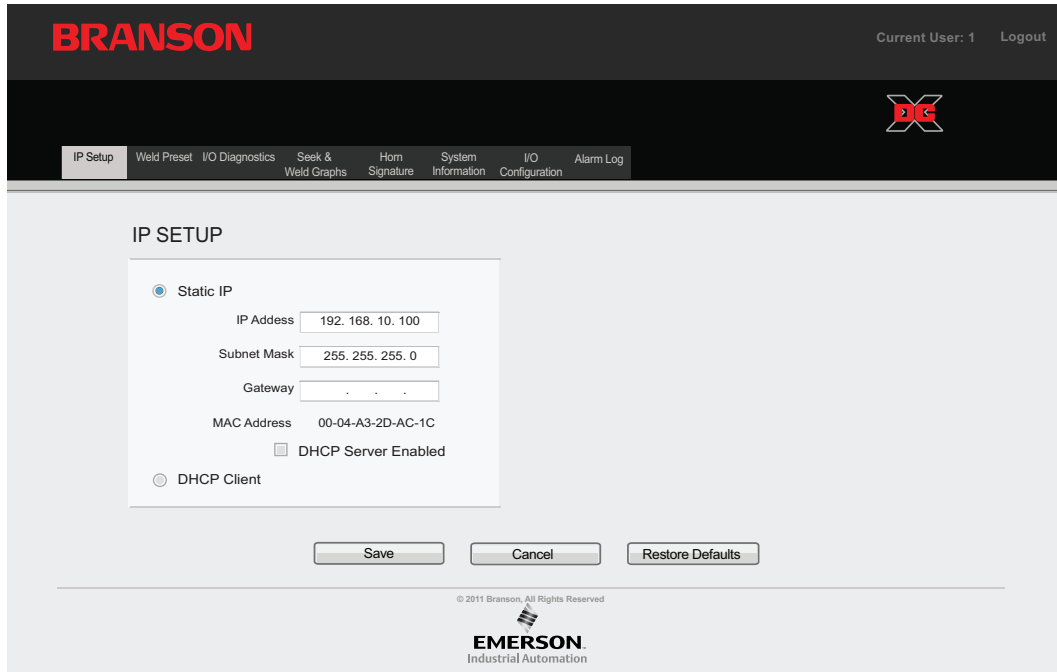



Table 4.2 IP Setup Menu Options

Name	Description
IP SETUP	
Static IP	Select this option to manually assign an IP address to the DCX Power Supply. The DCX Power Supply will alert if an invalid IP address setting is entered.
IP Address	The IP address assigned to the DCX Power Supply.
Subnet Mask	The mask used to determine to what subnet the DCX Power Supply's address belongs to.
Gateway	The gateway address assigned to the network for communication with other computers or networks.
MAC Address	Displays the MAC address assigned to the DCX Power Supply.
DHCP Server Enabled	Select this option to have DCX Power Supply assign IP addresses to any devices connected to it. This facilitates connecting a computer or laptop point to point (P2P) with the DCX Power Supply. NOTICE Connecting a DCX Power Supply with DHCP server enabled to a network which already has a device working as a DHCP server will cause connectivity problems.

Table 4.2 IP Setup Menu Options

Name	Description
DHCP Client	Select this option to have the DCX Power Supply automatically request an IP address from a DHCP Server. The IP address will be grayed out.

NOTICE	
	All changes on this menu take effect on the next power-up.

At any time you may determine the DCX Power Supply's IP address by going through the associated registers using the front panel LCD (for DCX S units). A Cold Start can also be performed to take your power supply back to its factory default IP address. For details on navigating the DCX registers or performing a Cold Start, consult your power supply manual.

NOTICE	
	Beware that other settings will also be reset to their defaults when a Cold Start is executed.

4.4 Weld Preset

Use this menu to set weld parameters, seek options, and power-up actions. Use the command buttons on the bottom to save settings, cancel changes, or to restore to factory default settings.

Figure 4.4 Weld Preset Menu

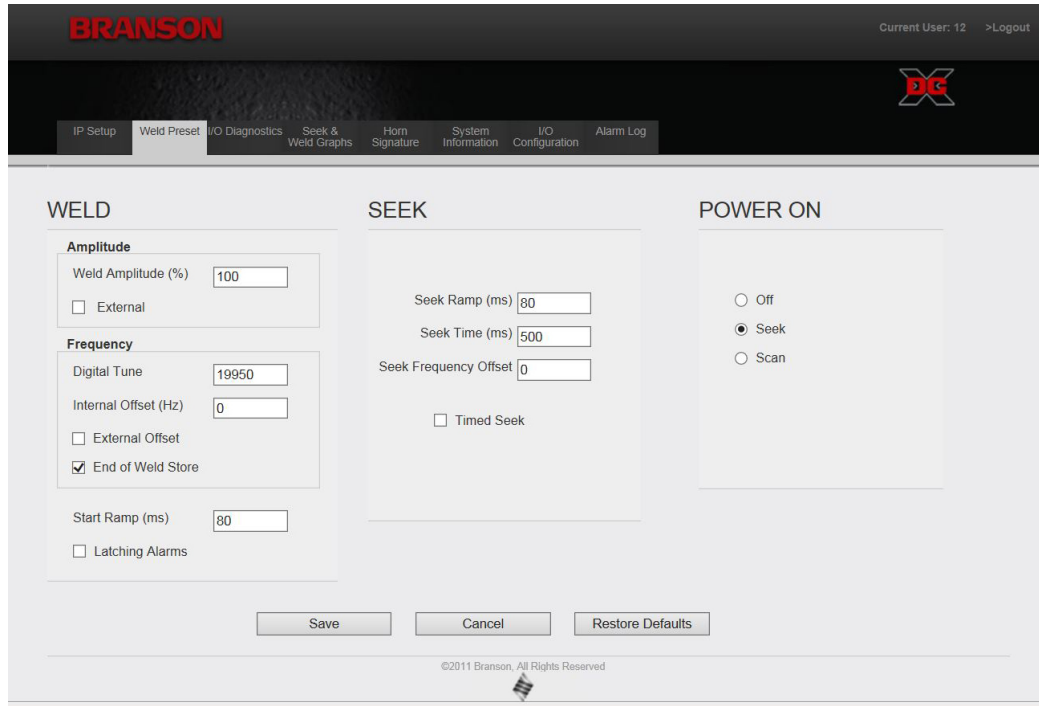

Table 4.3 Weld Preset Menu Options

Function	Description	
WELD		
Amplitude	The amplitude of ultrasonic energy that will be delivered by the DCX Power Supply. Valid range is between 10 to 100 (10% to 100% amplitude). Select the External check box to control the amplitude using an analog input from the user I/O connector (J3). (See 4.9 I/O Configuration .)	
Frequency Offset	The frequency offset applied to the power supply operating frequency. Select the External check box to control the frequency offset using an analog input from the user I/O connector (J3). (See 4.9 I/O Configuration .)	
	Frequency	Offset Range
	20 kHz	+/- 500 Hz
	30 kHz	+/- 750 Hz
	40 kHz	+/- 1000 Hz
Digital Tune	Starting frequency set from horn signature or manually entered.	

Table 4.3 Weld Preset Menu Options

Function	Description
Start Ramp (ms)	The time it takes for the amplitude to ramp up to 100% when the External Start signal is applied. If amplitude setting is lower than 100%, ramp time will be adjusted accordingly. Valid range is 1 to 999.
End of Weld Store	Select this check box to have the DCX Power Supply update the horn operating frequency at the end of each weld.
Latching Alarms	Select this check box to have the DCX Power Supply wait for a reset after an alarm condition. The Reset signal can be applied via the user I/O digital input or using front panel Reset key (DCX S units only). Clear this option to have the DCX Power Supply wait for only a toggle of the Start signal.
SEEK	
Seek Ramp (ms)	The time it will take the power supply to ramp-up when performing a seek. Valid range is 1 to 999.
Seek Time (ms)	The duration of a seek. Valid range is 1 to 999.
Timed Seek	Select this check box to have the power supply perform a seek every 60 seconds. Seeks will be timed from the moment sonics was last activated.
POWER ON	
Off	Select this option to disable power-on actions.
Seek	Select this option to have the power supply perform a seek on power-up.
Scan	Select this option to have the power supply perform a horn scan* on power-up.

* For a definition of Seek and Horn Scan, consult the DCX Instruction Manual.

4.5 I/O Diagnostics

Use this menu to monitor and control the DCX Power Supply digital and analog I/O. For user I/O configuration instructions see [4.9 I/O Configuration](#).



NOTICE	
	<p>The assigned power supply functions will not be performed by the power supply, only the signals levels can be controlled and monitored while in this menu.</p>
NOTICE	
	<p>Pin designation will reflect the current user I/O assignment.</p>

Figure 4.5 I/O Diagnostics Menu



BRANSON Current User: 1 Logout

IP Setup Weld Preset **I/O Diagnostics** Seek & Weld Graphs Horn Signature System Information I/O Configuration Alarm Log

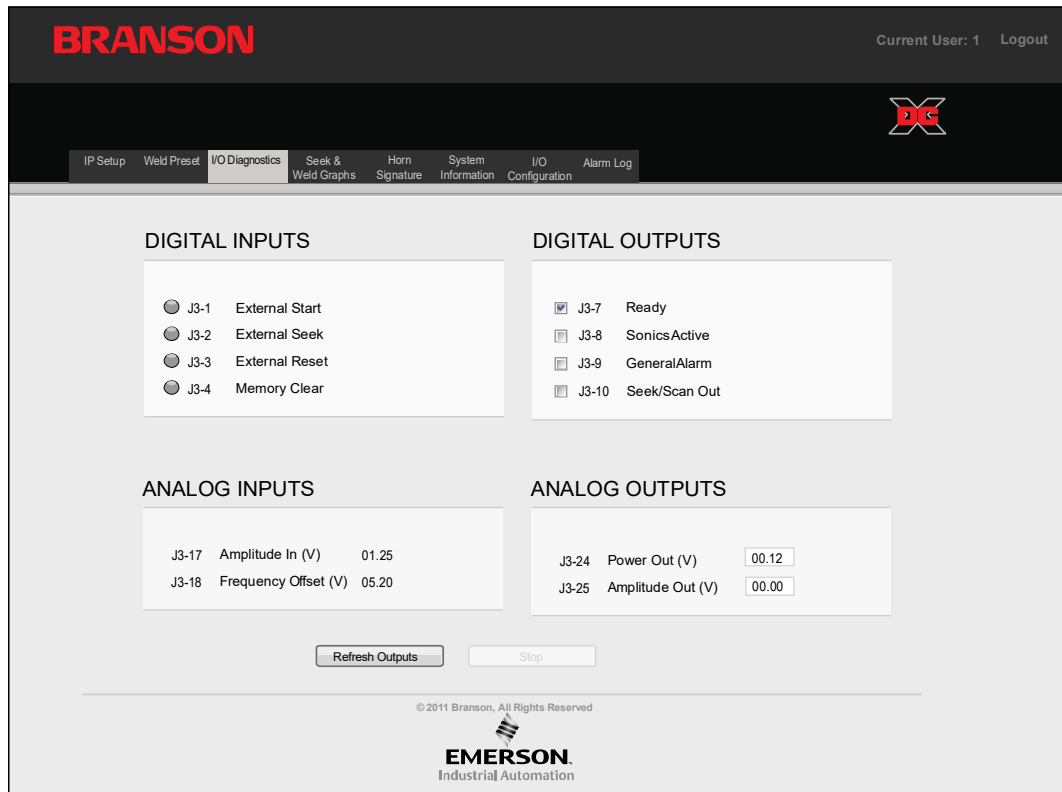
DIGITAL INPUTS

- J3-1 External Start
- J3-2 External Seek
- J3-3 External Reset
- J3-4 Memory Clear

DIGITAL OUTPUTS

- J3-7 Ready
- J3-8 SonicsActive
- J3-9 GeneralAlarm
- J3-10 Seek/Scan Out

ANALOG INPUTS

J3-17	Amplitude In (V)	01.25
J3-18	Frequency Offset (V)	05.20

ANALOG OUTPUTS

J3-24	Power Out (V)	<input type="text" value="00.12"/>
J3-25	Amplitude Out (V)	<input type="text" value="00.00"/>

© 2011 Branson, All Rights Reserved

EMERSON
Industrial Automation

Table 4.4 I/O Diagnostics Menu Options

Name	Description
DIGITAL INPUTS	
J3-1 to J3-4	Indicate if the digital inputs are active*. Function names will be displayed depending on the current I/O assignment: <ul style="list-style-type: none"> • Cable Detect • Display Lock (DCX S only) • External Horn Scan • External Reset • External Seek • External Start • External Test • Memory Clear
DIGITAL OUTPUTS	
J3-7 to J3-10	Select/clear check boxes to toggle available digital outputs on/off*. Function names will be displayed depending on the current I/O assignment: <ul style="list-style-type: none"> • General Alarm • Overload Alarm • Ready • Seek/Scan Out • Sonics Active
ANALOG INPUTS	
J3-17 and J3-18	Displays the current analog input values: Function names will be displayed depending on the current I/O assignment: <ul style="list-style-type: none"> • Amplitude In (V): Valid range is 1 to +10 V (10% to 100%**) • Frequency Offset (V): Valid range is 1 to 9 V (5 V is zero offset**)
ANALOG OUTPUTS	
J3-24 and J3-25	Allows control of analog output values: Function names will be displayed depending on the current I/O assignment: <ul style="list-style-type: none"> • Amplitude Out (V): Valid range is 0 to 10 V • Frequency Out (V): Valid range is 0 to 10 V • Power Out (V): Valid range is 0 to 10 V
COMMAND BUTTONS	
Refresh Outputs	Click on this button to update digital and analog outputs.
Stop	Click on this button to stop controlling the digital and analog outputs.

* Digital I/O functions can be configured to either active-high (positive logic) or active-low (negative logic).
 For more information see [4.9 I/O Configuration](#).

** If the input signals are not within their valid range, or if left unconnected, the power supply will use 50% amplitude and zero frequency offset, respectively.

4.6 Seek & Weld Graphs

Use this menu to test your system. This feature allows you to capture 5 seconds of welding data which you can both view and export. The Weld Data Graph is provided with 6 available parameters: Phase, Current, Amplitude, Power, PWM Amplitude, and Frequency. Each parameter has a checkbox to the left of its name. Only checked parameters will be displayed. While in this menu, if the Weld is being run from external I/O or the custom LCD, the graph can be also displayed on the screen by using the "Update Graph" button.

Figure 4.6 Seek & Weld Graphs Menu

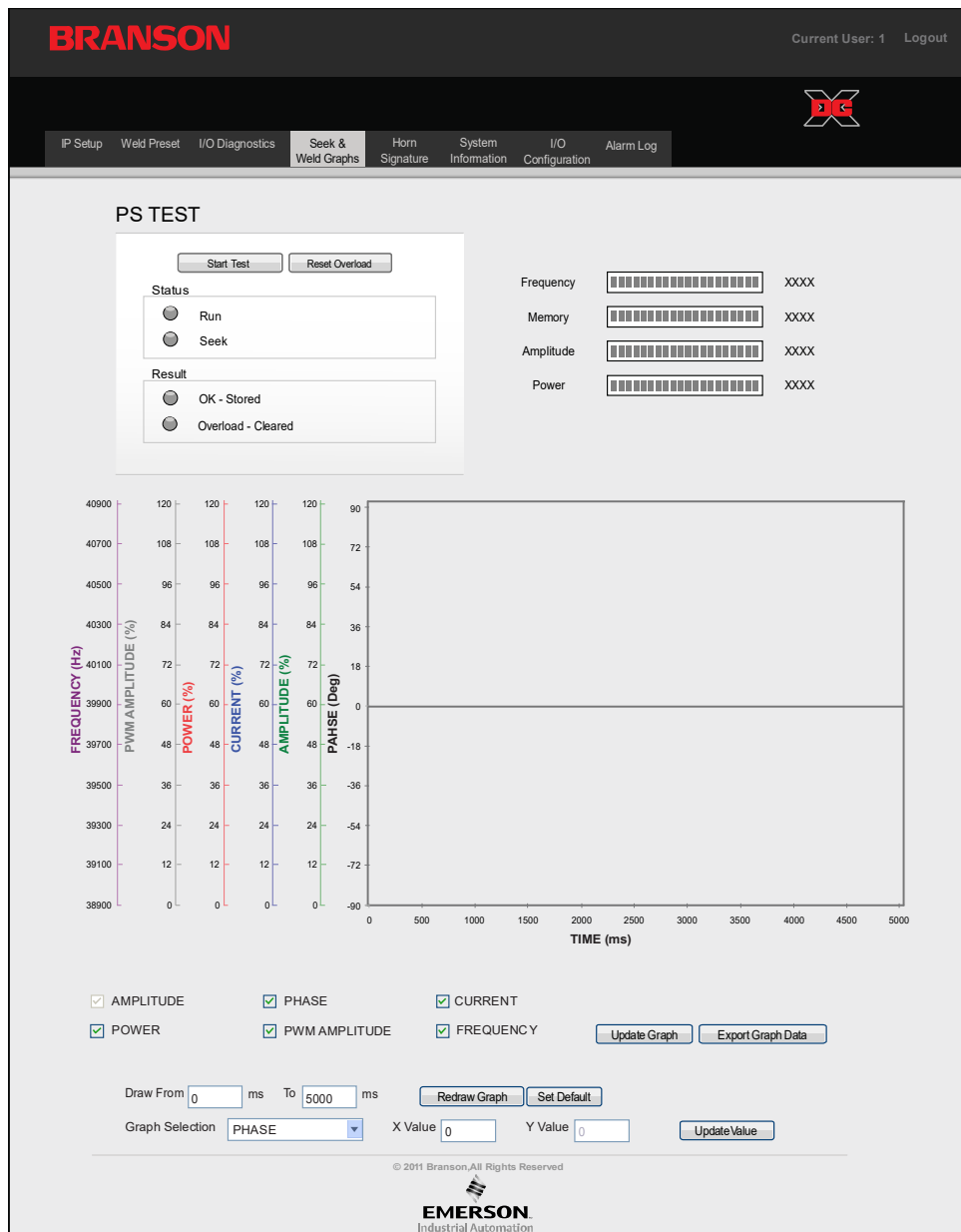



Table 4.5 Seek and Weld Graphs Menu Options

Name	Description
P/S TEST	
Start Test	Click to perform a test cycle.
Reset Overload	Click to reset an overload condition.
Run	Indicates that ultrasonic energy is on.
Seek	Indicates that power supply is running at 10% amplitude for the purpose of finding the ultrasonic stack resonant frequency.
OK - Memory Stored	Indicates that the horn operating frequency was stored in the DCX Power Supply memory.
Overload - Memory Cleared	Indicates that test resulted in an overload and the memory has been cleared.
Frequency	Monitors the horn operating frequency.
Memory	Displays the frequency stored in the DCX Power Supply memory.
Amplitude	Displays the percentage of converter amplitude.
Power	Displays the percentage of power output.
Update Graph	Click to get the value of all the parameter and draw the graph for Phase, Current, Amplitude, Power, and Frequency parameters vs Time on the Y axis.
Export Graph Data	Click to export the Weld Graph data with Weld Preset settings to CSV file.
Redraw Graph	Click to redraw the same graph with those parameters which are checked with the Time parameter on Y axis.
Draw from... to...	Select the "from" and "to" time values to zoom into the desired graph region.
Graph Selection	Select a parameter and enter a particular X time value to obtain the corresponding Y value at that particular time.
Update Value	Click to update the Y value.
Set Default	Click to return the same rate, start time, end time and graph selection to default settings.
User Comment Box	Enter comments to be added at the top of exported file in CSV file.

NOTICE	
	Always clean your Internet browsing history before getting a Weld Graph data.

Refer to [Appendix A](#) for information on Ultrasonic Welding.

4.7 Horn Signature

Use this menu to diagnose your ultrasonic horn. When performing a horn scan, ideally, there will be only one resonant frequency. The Horn Signature graph is provided with 3 available parameters: Phase, Current, and Amplitude. The horn Signature Graph can be both viewed and exported.

Each parameter has a checkbox to the left of its name. Only checked parameters will be displayed.

Figure 4.7 Horn Signature Menu

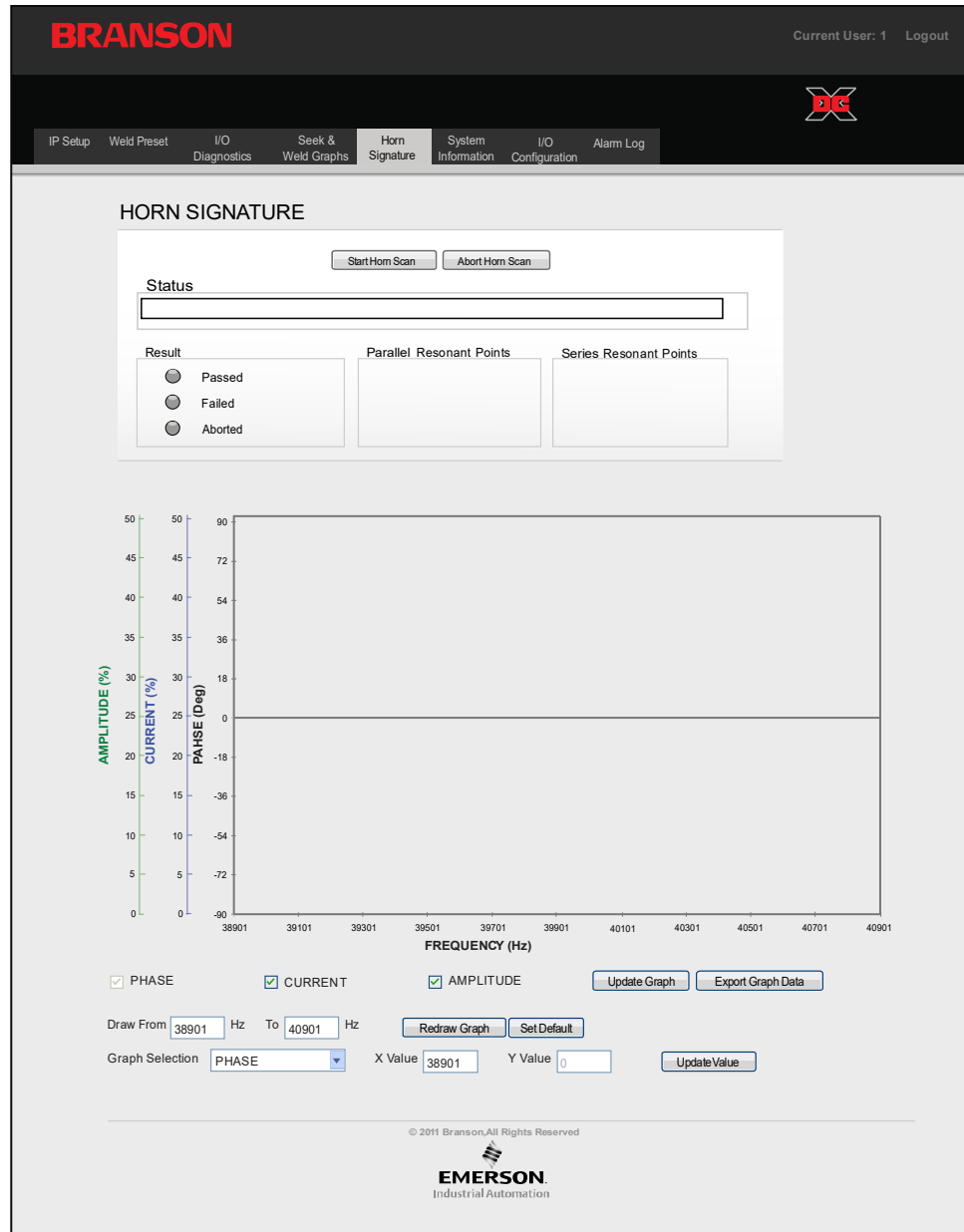



Table 4.6 Horn Signature Menu Options

Name	Description
HORN SIGNATURE	
Start Horn Scan	Click to initiate the horn scan.
Abort Horn Scan	Click to abort the horn scan.
Status	Indicates the horn scan progress.
Result	Indicates if the horn scan passed, failed or if the operation was aborted.
Parallel Resonant Points	<p>Displays the parallel resonant frequencies of the ultrasonic horn. The parallel resonant frequency is the operating frequency of the ultrasonic stack.</p> <p>NOTICE If multiple parallel frequencies are found, they will all be listed. The frequency at which the ultrasonic stack is running will be displayed in blue.</p>
Series Resonant Points	Displays the series resonant frequencies of the ultrasonic horn.
Update Graph	Click to draw the graph of the last horn scan.
Export Graph Data	Click to export the scan graph data with scan settings to CSV file.
Redraw Graph	Click to redraw the same graph with those parameters which are checked with the Time parameter on Y axis.
Draw from... To...	Select the "from" and "to" time values to zoom into the desired graph region.
Graph Selection	Select a parameter and enter a particular X time value to obtain the corresponding Y value at that particular time.
Update Value	Click to update the Y value.
Set Default	Click to return the sample rate, start time, end time and graph selection to default settings.
User Comment Box	Enter comments to be added at the top of exported data in CSV file.

NOTICE	
	<p>Always clean your Internet browsing history before getting a Scan Graph data.</p>

Refer to [A.4 Resonance Analysis](#) and [A.4.2 Scan Horn Error Analysis](#) for Horn Scan Analysis.

4.8 System Information

Use this menu to view information about your DCX Power Supply. Have the information on this screen available when calling Branson for troubleshooting help.

Figure 4.8 System Information Menu

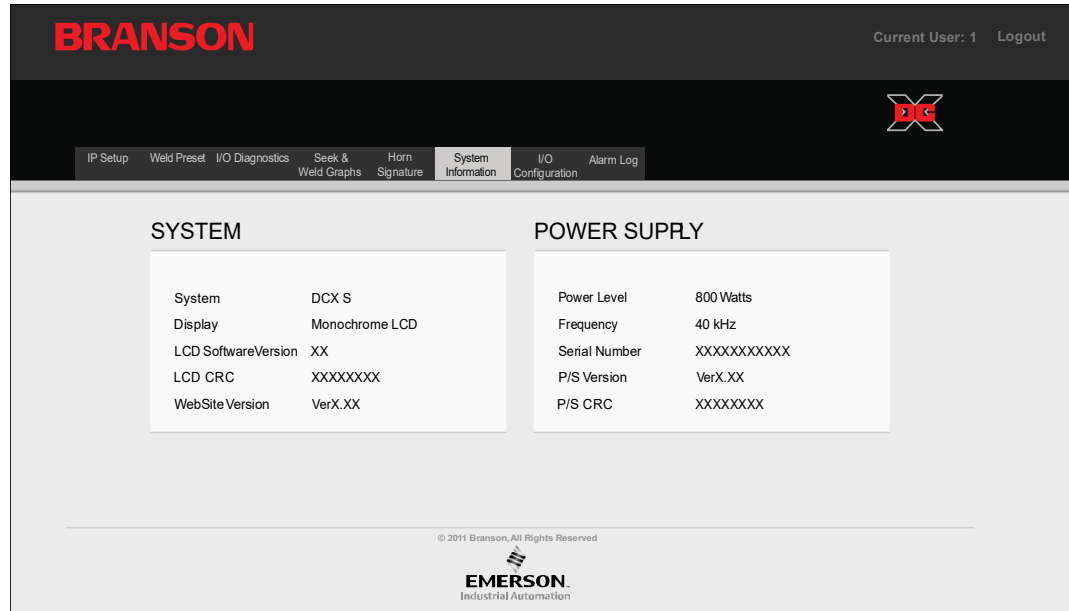

Table 4.7 System Information Menu Display

Name	Display
SYSTEM	
System	Display the DCX Power Supply model name.
Display	Displays the type of front panel user interface on the DCX Power Supply.
LCD Software Version	Displays the LCD software version number.
LCD CRC	Shows the CRC code of the LCD software.
WebSite Version	Displays the Web Page version number.
POWER SUPPLY	
Power Level	Displays the power supply wattage.
Frequency	Displays the power supply operating frequency.
Serial Number	Displays the power supply serial number.
P/S Version	Displays the power supply software version number.
CRC	Shows the CRC code of the power supply controller software.

4.9 I/O Configuration

Use this menu to configure the DCX Power Supply I/O according to your specific interfacing needs. Use the command buttons on the bottom to save settings, cancel changes, or to restore to factory default settings.

WARNING	
	<p>General Warning</p> <p>When using 0 V to activate ultrasonics (External Start signal), it is recommended to assign one input as Cable Detect to prevent sonics from activating if 24 V is lost by accident.</p>

Figure 4.9 I/O Configuration Menu



The screenshot displays the Branson I/O Configuration web interface. At the top, the Branson logo is on the left, and 'Current User: 1 Logout' is on the right. A navigation menu below the logo includes 'IP Setup', 'Weld Preset', 'I/O Diagnostics', 'Seek & Weld Graphs', 'Horn Signature', 'System Information', 'I/O Configuration' (highlighted), and 'Alarm Log'. A red 'DC' logo is also present in the top right.

The main content area is divided into four quadrants:

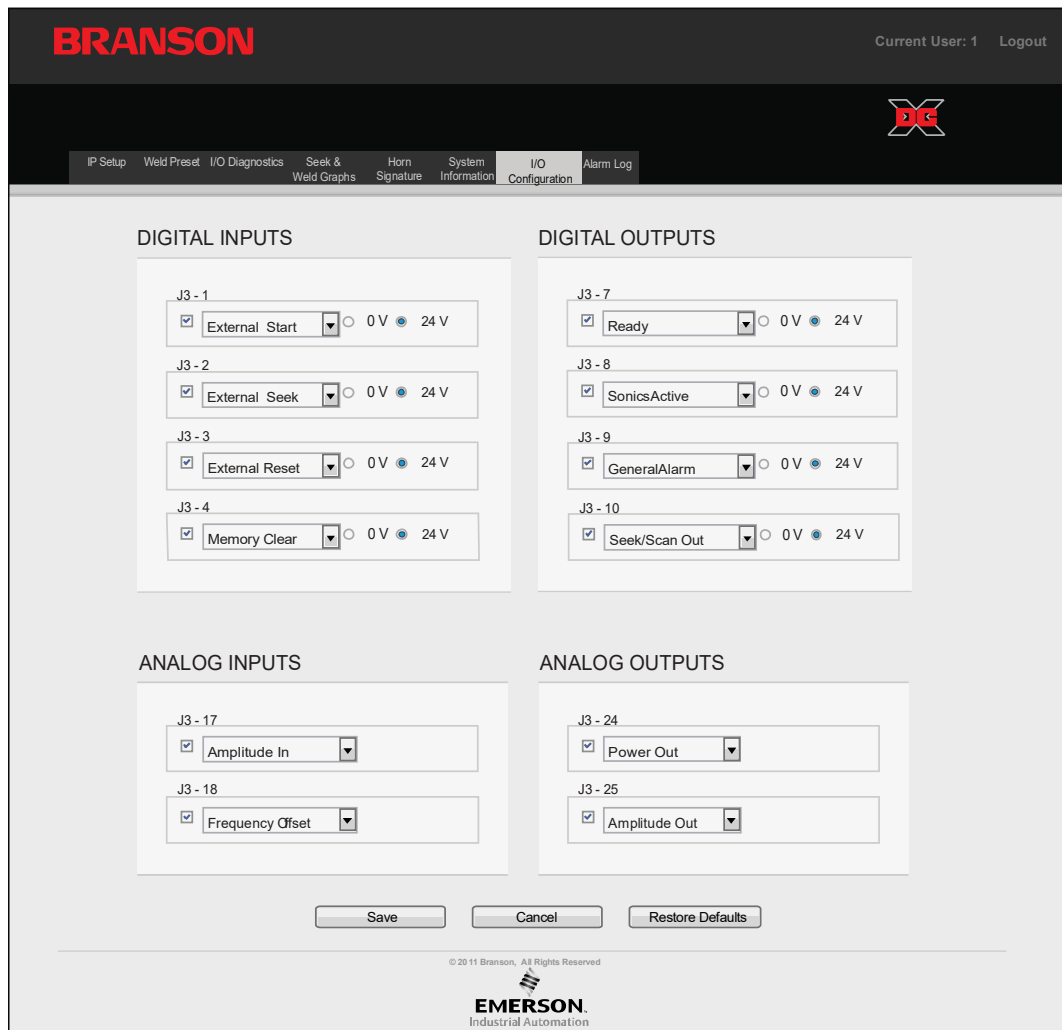
- DIGITAL INPUTS:**
 - J3 - 1: External Start, 0 V (radio), 24 V (radio)
 - J3 - 2: External Seek, 0 V (radio), 24 V (radio)
 - J3 - 3: External Reset, 0 V (radio), 24 V (radio)
 - J3 - 4: Memory Clear, 0 V (radio), 24 V (radio)
- DIGITAL OUTPUTS:**
 - J3 - 7: Ready, 0 V (radio), 24 V (radio)
 - J3 - 8: SonicsActive, 0 V (radio), 24 V (radio)
 - J3 - 9: GeneralAlarm, 0 V (radio), 24 V (radio)
 - J3 - 10: Seek/Scan Out, 0 V (radio), 24 V (radio)
- ANALOG INPUTS:**
 - J3 - 17: Amplitude In
 - J3 - 18: Frequency Offset
- ANALOG OUTPUTS:**
 - J3 - 24: Power Out
 - J3 - 25: Amplitude Out

At the bottom of the configuration area are three buttons: 'Save', 'Cancel', and 'Restore Defaults'. The footer contains the copyright notice '© 2011 Branson, All Rights Reserved' and the Emerson Industrial Automation logo.

4.9.1 Available Digital Input Functions

Table 4.8 Available Digital Input Functions

Function	Description
Cable Detect	Disables ultrasonics if 24 V signal is removed when using 0 V negative logic (active low) for the external Start input. Used to prevent ultrasonics from coming on if a cable is removed.
Display Lock	Locks the front panel display controls.
External Horn Scan	Starts horn scan sequence.
External Reset	Resets alarm conditions.
External Seek	Activates ultrasonic energy at 10 % amplitude for the purpose of finding the ultrasonic stack resonant frequency.
External Start	Activates ultrasonic energy at the currently set amplitude. WARNING When using 0 V to activate ultrasonics (External Start signal), it is recommended to assign one input as Cable Detect to prevent sonics from activating if 24 V is lost by accident.
External Test	Performs a test cycle.
Memory Clear	Centers the power supply start frequency.

4.9.2 Available Digital Output Functions

Table 4.9 Available Digital Output Functions

Function	Description
General Alarm	Indicates an alarm occurred.
Overload Alarm	Indicates an overload alarm has occurred.
Ready	Indicates the system is ready.
Seek/Scan Out	Indicates either a seek or a horn scan is in progress.
Sonics Active	Indicates sonics are active.

4.9.3 Available Analog Input Functions

Table 4.10 Available Analog Input Functions

Function	Description	
Amplitude In	Controls the amplitude of ultrasonic energy that will be delivered by the power supply.	
Frequency Offset	Controls the frequency offset to the power supply operating frequency. Actual offset depends on the power supply operating frequency:	
	Frequency	Offset Range
	20 kHz	±400 Hz
	30 kHz	±600 Hz
40 kHz	±800 Hz	

4.9.4 Available Analog Output Functions

Table 4.11 Available Analog Output Functions

Function	Description		
Amplitude Out	Provides a 0 V to 10 V output signal proportional to amplitude (0% to 100%).		
Power Out	Provides a 0 V to 10 V output signal proportional to ultrasonic power output (0% to 100%).		
Frequency Out	Provides a 0 V to 10 V output signal that indicates relative frequency in memory. Actual frequency depends on the power supply operating frequency:		
	Frequency	Lower Limit (0 V)	Upper Limit (10 V)
	20 kHz	19,450 Hz	20,450 Hz
	30 kHz	29,250 Hz	30,750 Hz
40 kHz	38,900 Hz	40,900 Hz	

4.10 Alarm Log

Use this screen to view the DCX Power Supply alarm history. The alarms can be sorted by alarm number or alarm type. Alarms can be exported to an Excel[®]* file.

NOTICE	
	Only the last 100 alarms are stored in memory.

Figure 4.10 Alarm Log Menu



The screenshot displays the Branson DCX Alarm Log interface. At the top, the 'BRANSON' logo is on the left, and 'Current User: 1 Logout' is on the right. Below the logo is a red 'DCX' icon. A navigation menu includes 'IP Setup', 'Weld Preset', 'I/O Diagnostics', 'Seek & Weld Graphs', 'Horn Signature', 'System Information', 'I/O Configuration', and 'Alarm Log' (which is highlighted). The main content area features a table with the following columns: 'Alarm # ▲', 'Date', 'Time', 'Alarm •', 'UserID', 'Data1', and 'Data2'. The table body is currently empty. Below the table are two buttons: 'Clear Log' and 'Export to Excel'. At the bottom, there is a copyright notice: '© 2011 Branson, All Rights Reserved' and the 'EMERSON Industrial Automation' logo.

Table 4.12 Alarm Log Menu Display

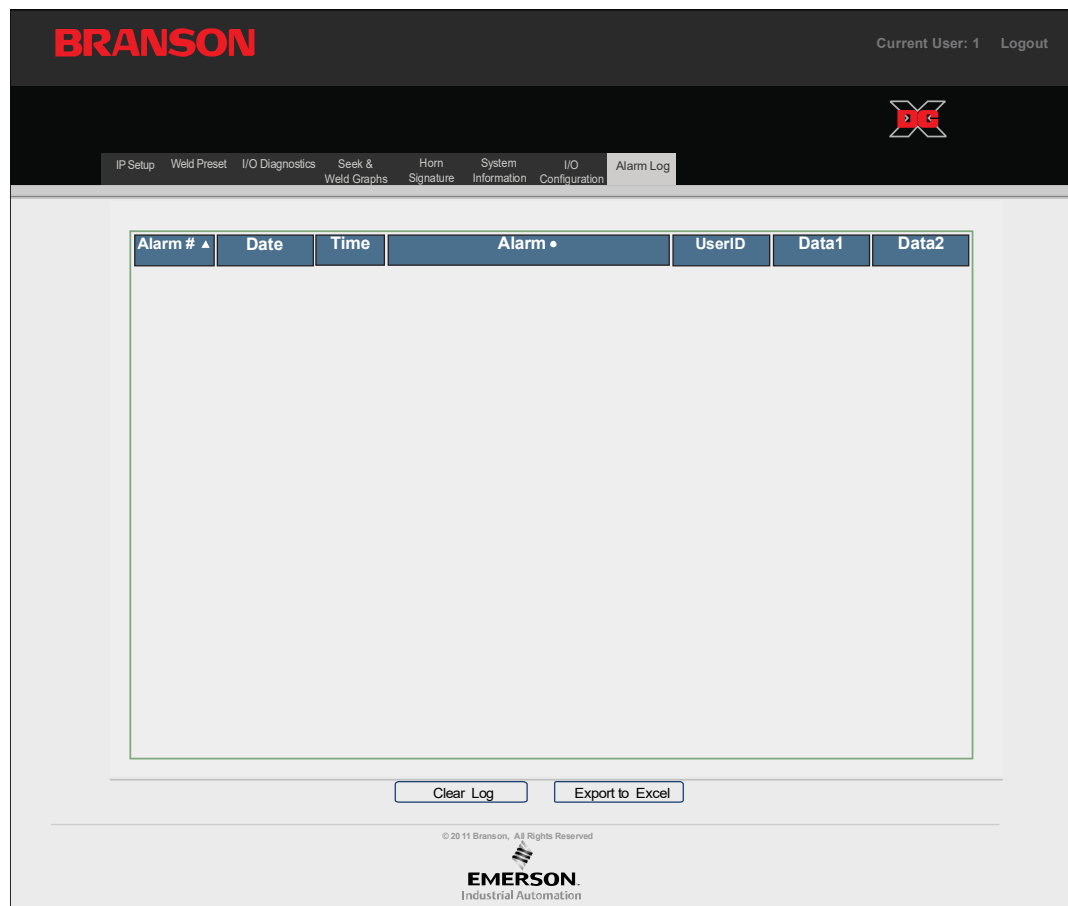
Name	Description
Alarm #	A unique alarm identification number. This number will reset to zero if the alarm log is cleared.
Date / Time	The DCX S and DCX V units do not feature an integrated real time clock. Alarm date and time account for the power-on hours from the moment the DCX Power Supply was first turned on.
UserID	The ID number of the user logged in at when the alarm occurred. Will display zero if the alarm occurs from an external weld.
Data1 / Data2	For future use.
ALARM DESCRIPTIONS	
Frequency - High Seek Limit	Frequency reached high end limit: 20 kHz 20.450 kHz 30 kHz 30.750 kHz 40 kHz 40.900 kHz.
Frequency - Low Seek Limit	Frequency reached low end limit: 20 kHz 19.450 kHz 30 kHz 29.250 kHz 40 kHz 38.900 kHz
Frequency - High Weld Limit	Frequency reached high end limit: 20 kHz 20.450 kHz 30 kHz 30.750 kHz 40 kHz 40.900 kHz
Frequency - Low Weld Limit	Frequency reached low end limit: 20 kHz 19.450 kHz 30 kHz 29.250 kHz 40 kHz 38.900 kHz
Overload - Current	RF current peak limit reached.
Overload - Frequency	Frequency reached high or low end limit. Frequency number are same as above depending on the system (20 kHz, 30 kHz, 40 kHz).
Overload - Power Limit	Power supply reached 115% rated power.
Overload - Temperature	IGBT heat sink temperature limit is reached.
Overload - Voltage	RF voltage peak limit reached.
Phase Limit Time Error	When power supply out of tune phase limit error is reached after 500ms (default time).
COMMAND BUTTONS	

Table 4.12 Alarm Log Menu Display

Name	Description
Clear Log	Click to clear the alarm log.
Export to Excel	Click to download an Excel [®] * spreadsheet file of the alarm log.

*Excel is a registered trademark of Microsoft Corporation.

Refer to [A.6 DCX Alarms Table](#) for more detailed information about the condition that led to the alarm and the corrective action you should take.



Appendix A: Information on Ultrasonic Welding

A.1	Introduction	40
A.2	Resonance	41
A.3	The Principle and the Components of Ultrasonic Welding	42
A.4	Resonance Analysis	45
A.5	Graphics of a Weld	49
A.6	DCX Alarms Table	54

A.1 Introduction

This section provides details on ultrasonic welding. Among other, these details are important in order to be able to understand the graphics. In section [A.4.2 Scan Horn Error Analysis](#) you will also find information on error analysis.

A.2 Resonance

Every solid body has its natural resonance. This is determined by the material it is made of and its total mass.

If, for example, a spanner falls on the ground, the typical metallic sound is generated. If we would measure the tone pitch, we would have determined the natural resonance of the spanner. Another classic example is the tuning fork. It is designed in a manner that it exactly vibrates at 440 Hz (philharmonic pitch A).

These are examples for resonance in the audible range (approx. 40 Hz to 16 kHz). Starting from a frequency of 20 kHz this is referred to as ultrasonics. Also, any combination of converter, booster, and horn has its natural resonance.

The aim is to utilize this resonance in order to achieve a maximum effect at lowest possible energy consumption. This is the case if - to ease the explanation - the vibrating frequency feed in corresponds to the resonant frequency of the acoustic stack. In this respect, it is important that an acoustic stack has two resonance points: a serial and a parallel one. The parallel resonance point is the decisive one.

A.3 The Principle and the Components of Ultrasonic Welding

A.3.1 The Principle

The tool vibrating at ultrasonic frequency is pressed onto the plastic parts to be welded. As the plastic material has the property extensively to absorb the vibrations fed in, this results in heating up of the joints up to the melting point. The mechanical pressure exerted generates a flow of the plasticized material between the two parts.

After cooling down, a virtually homogeneous joint is the result.

A.3.2 The Components

Figure A.1 The Components of an US Welding System

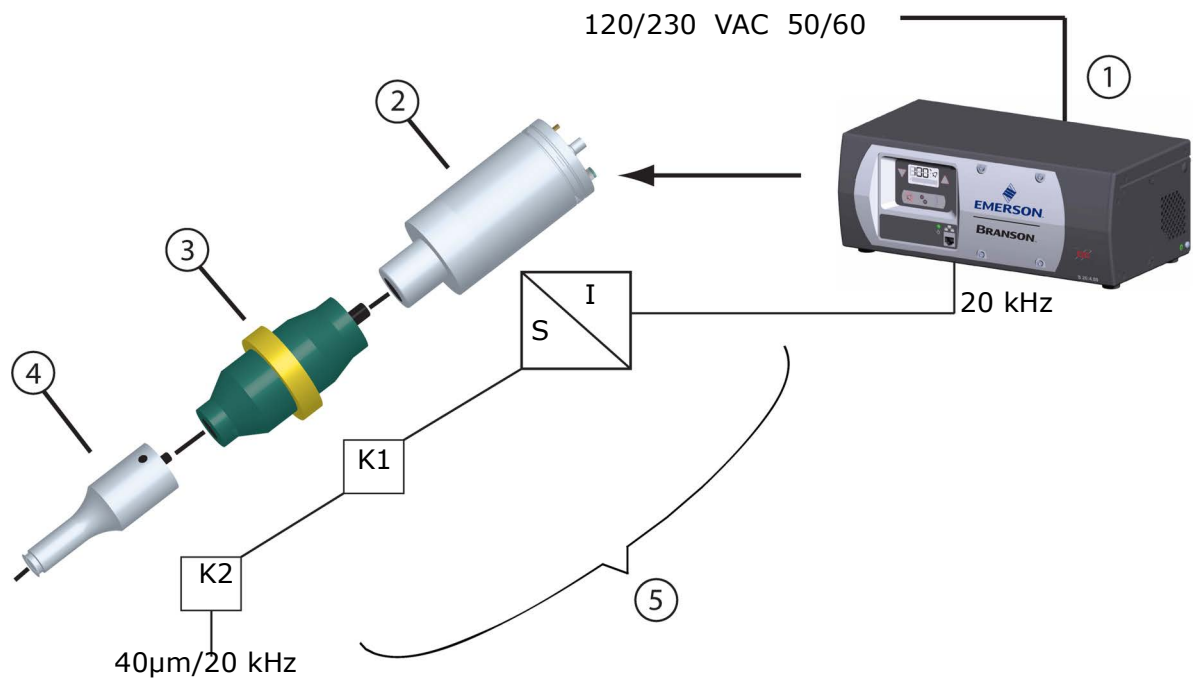

Table A.1 Components of an US Welding System

Item	Description
1	US Power Supply
2	Converter
3	Booster
4	Horn
5	Acoustic Stack

The power supply (1) transforms the energy supplied at 50/60 Hz from the mains to an ultrasonic frequency of 20 kHz.

The high-frequency electrical oscillations of the power supply are transformed by the converter (2) via a piezoelectric oscillator into mechanical vibrations of the same frequency, i. e. into mechanical vibrations at 20 kHz.

The mechanical vibrations must be transferred to the plastic part to be welded via an acoustic tool combination of booster (3) and horn (4). The booster amplifies the amplitude of the mechanical vibration (amplification factor K1).

The Booster

Not for all applications, a booster is required. The amplitude is amplified according to the energy conservation law. To amplify the amplitude of the vibration the cross-sectional area of the booster is varied. As the vibratory energy must remain constant over the whole length of the booster (energy conservation law) the amplitude is amplified proportional to the area ratio. This process can be illustrated by an undamped spring-mass system. When the spring-mass system is excited it will emerge that the short thick spring has a shorter elongation compared to the thin long spring although both spring oscillate at the same frequency. For the ratio the following formula applies:

$$F = \frac{A_e}{A_a} = \frac{V_e}{V_a} = \frac{M_e}{M_a}$$

Where:

- A_e = Input Amplitude
- A_a = Output Amplitude
- V_e = Input Oscillating Velocity
- V_a = Output Oscillating Velocity
- M_e = Input Mass
- M_a = Output Mass

Figure A.2 Amplitude Transformation Via the Booster

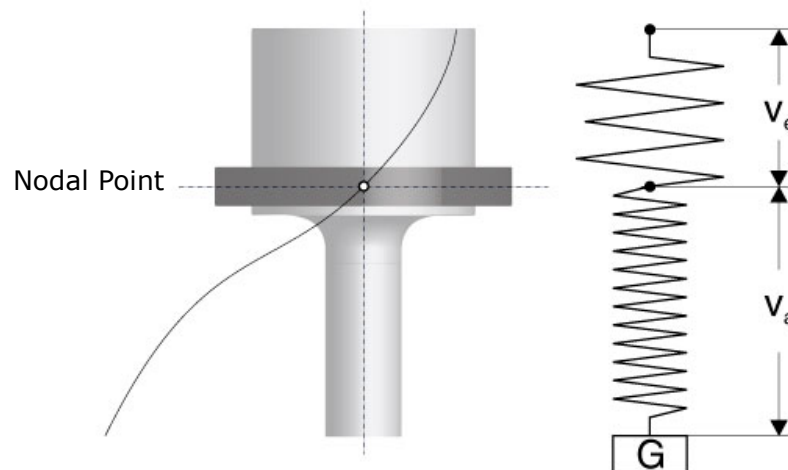

The Horn

The horn (also: welding tool) transmits the mechanical vibrations transformed by the converter and amplified by the booster to the plastic part.

Not only the booster but also the horn can amplify the amplitude (amplification factor K_2). For calculation of the amplitude ratios almost the same approach applies as for boosters.

Figure A.3 Commonly Used Horn Shapes

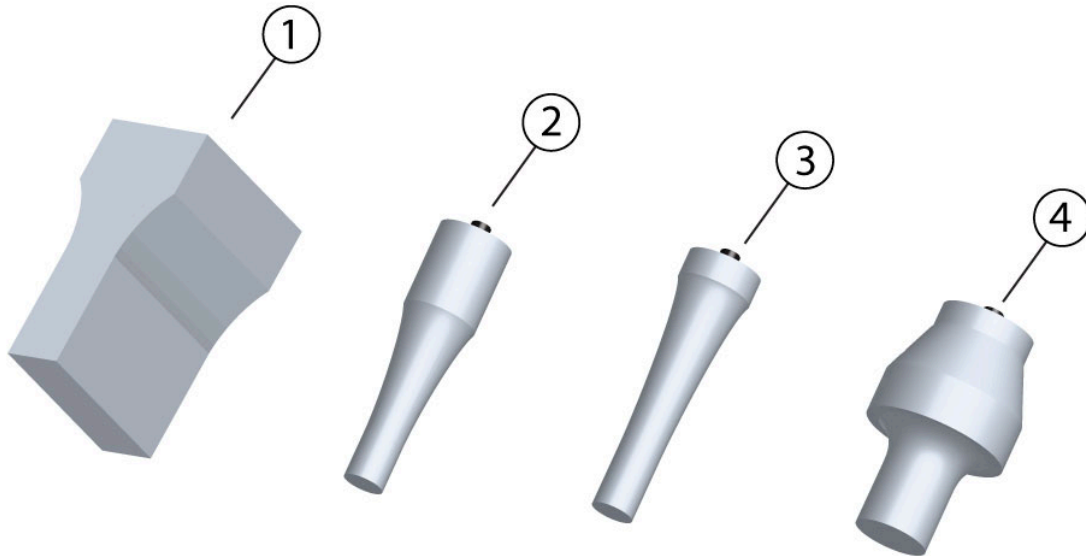

Table A.2 Commonly Used Horn Shapes

Item	Description
1	Rectangular Horn
2	Catenoidal Horn
3	Exponential Horn
4	Step Horn

The combination of converter, booster and horn is referred to as **acoustic stack**.

The prerequisite for a transfer of ultrasonic vibrations to the workpiece without losses is a transfer of acoustic energy between the individual components of acoustic stack with the lowest possible amount of reflection. The quality of the transfer essentially depends on the assembly of the individual components.

A.4 Resonance Analysis

The acoustic stack is an acoustic precision tool that, like any other tool, is subject to wear.

Depending on load, maintenance, and conditioning of this tool, defects may occur: the threaded joints between the components may become loose, deposit may build up at the mating surfaces, or cracks may be generated in the horn. The result: the resonant properties of the acoustic stack are impaired. The quality of the weld is reduced, and the power supply frequently switches to overload state.

For this reason, the DCX Web Page Interface provides the possibility to “scan” the acoustic stack. This means that ultrasonics is applied, with the ultrasonics frequency going through a preset frequency range, e. g. 19500 Hz to 20500 Hz. In the course of this, taking preset values, e. g. for amplitude and step width, into account, important characteristics like output current and phase are recorded and shown graphically on the display.

The curves of phase, amplitude, and current over the frequency indicate the points of serial resonance and parallel resonance of the acoustic stack. The parallel resonance relevant for operation lies at the point at which the algebraic sign of the phase changes the second time.

A.4.1 Getting a Horn Scan Data

Click the Start Horn Scan button to initiate the horn scan, the progress of the Scan is displayed on progress bar. When the Scan is completed, the Scan data is imported. During import a message appears as shown below. Message is automatically cleared when all data is received for graph.

Figure A.4 Getting Scan Data

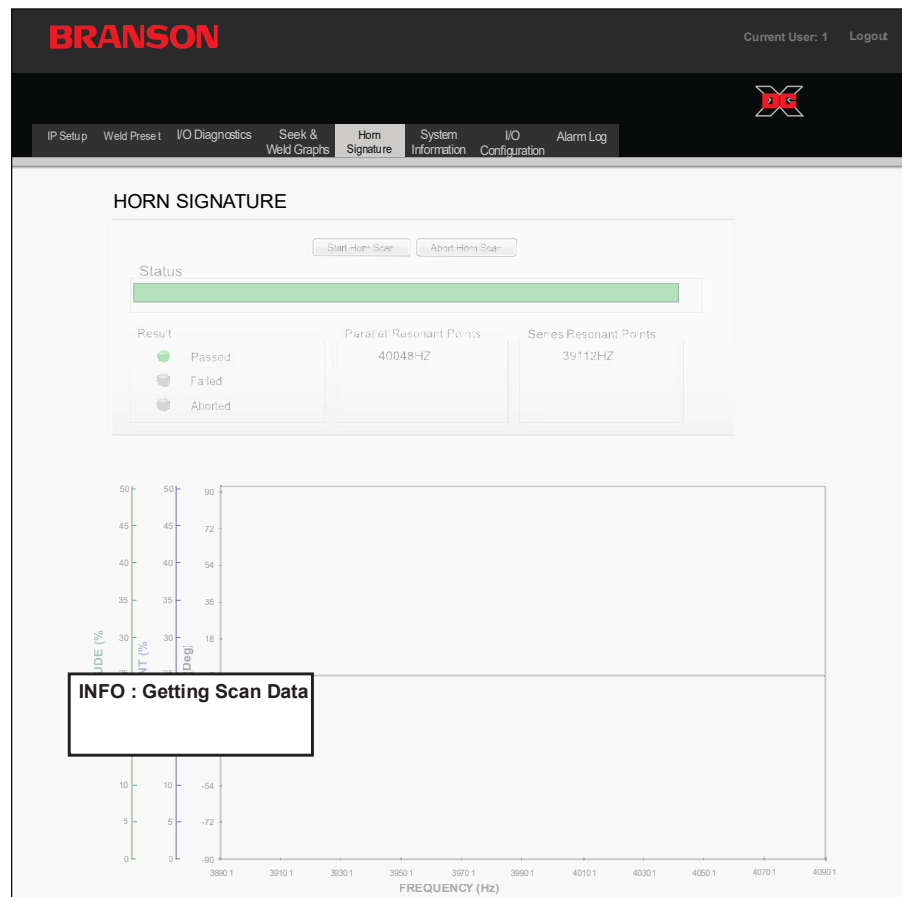

A scan is an automatic frequency seek. The values determined are stored and graphically displayed. The values inform about the resonance properties of the system. When you compare the curve with other curves you can draw conclusions with respect to the functioning and the acoustic properties of the acoustic stack.

In the course of the scan, ultrasonics are applied to the acoustic stack (converter/booster/horn) without load. The stack freely vibrates in the air, starting with a start frequency that is continually increased up to the adjusted end frequency.

Figure A.5 Graphics of a scan

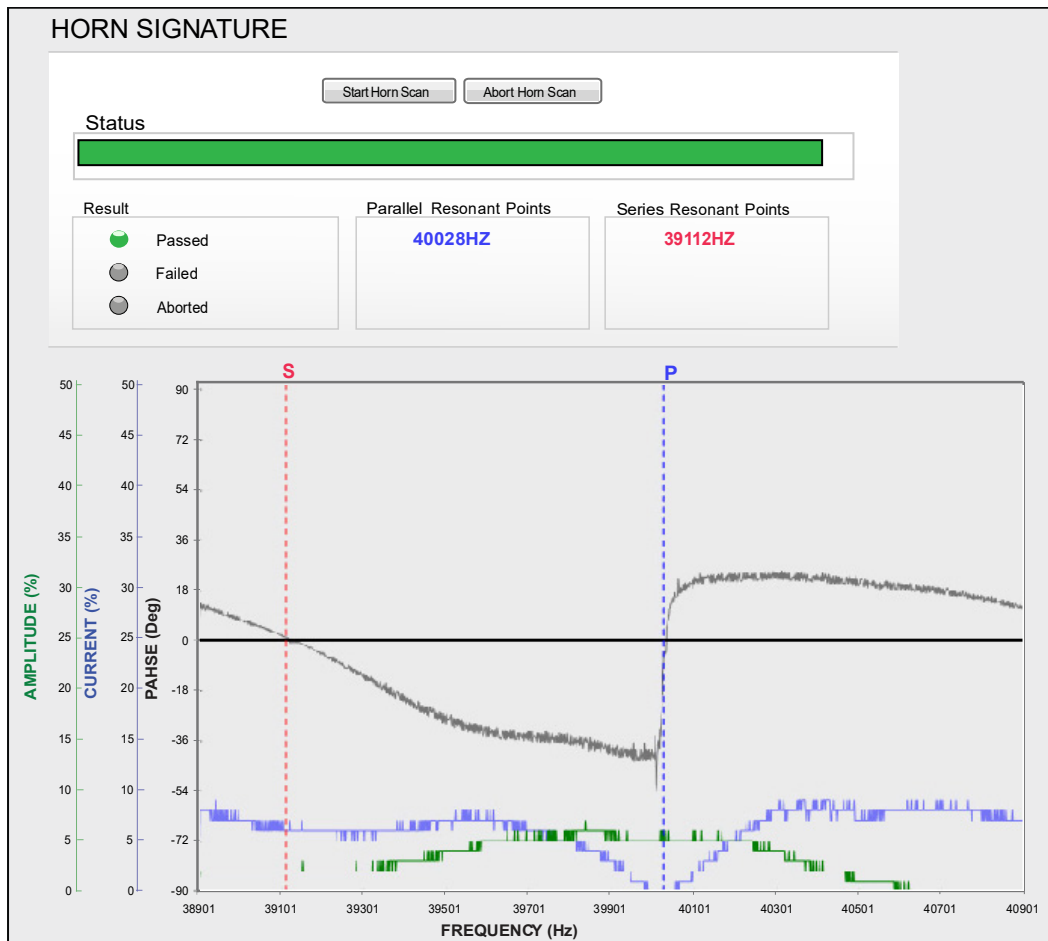

At the point of resonance, the current falls, the amplitude is at the maximum value, and the phase changes its sign.

NOTICE	
	<p>If multiple parallel frequencies are found, they will all be listed under Parallel Resonant Points. The frequency at which the acoustic stack is running will be shown in blue.</p>

A.4.2 Scan Horn Error Analysis

On the following pages, typical sources of error are shown.

Compare your system's curves with these examples to identify some of the possible problems you may encounter.

Figure A.6 Horn Scan, Possible Defective Converter

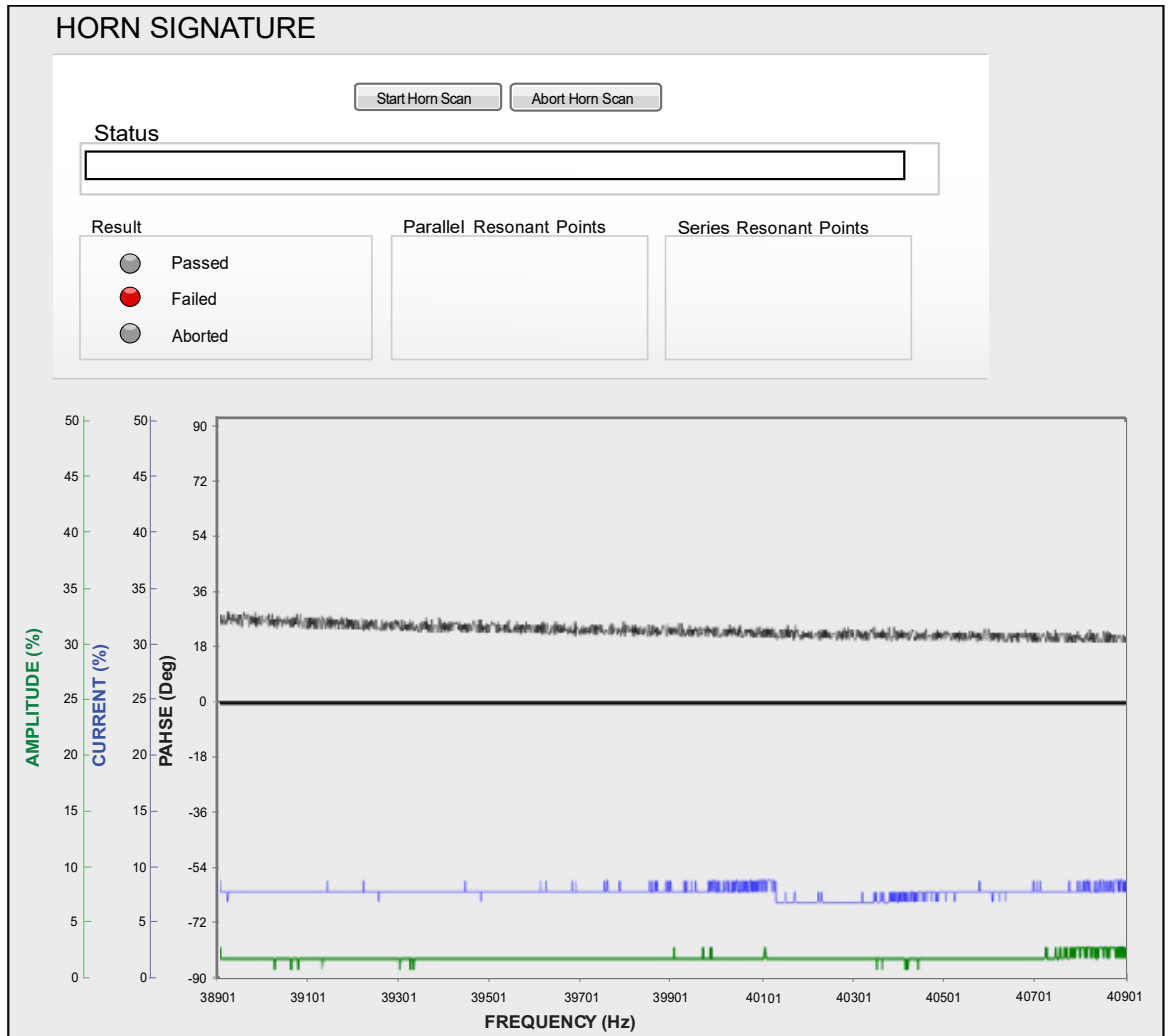
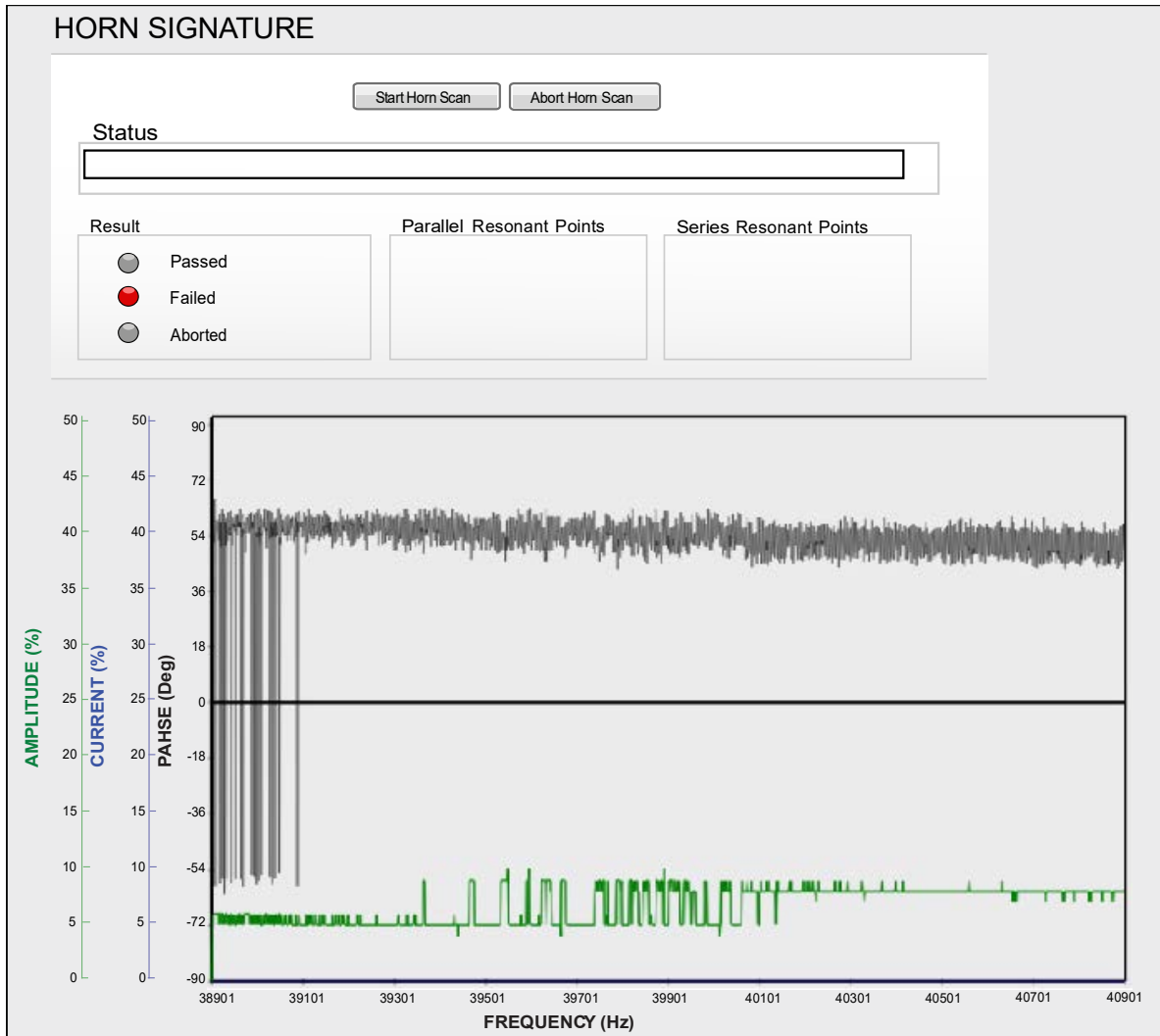

Figure A.7 Horn Scan, Open RF Cable



A.5 Graphics of a Weld

Weld Values can also be displayed as curves.

When you click on the Update Graph button, the Weld data is imported. While data is being transferred a message is appears, as shown below. Message is automatically cleared when all data is received for graph.

Figure A.8 Getting Weld Data

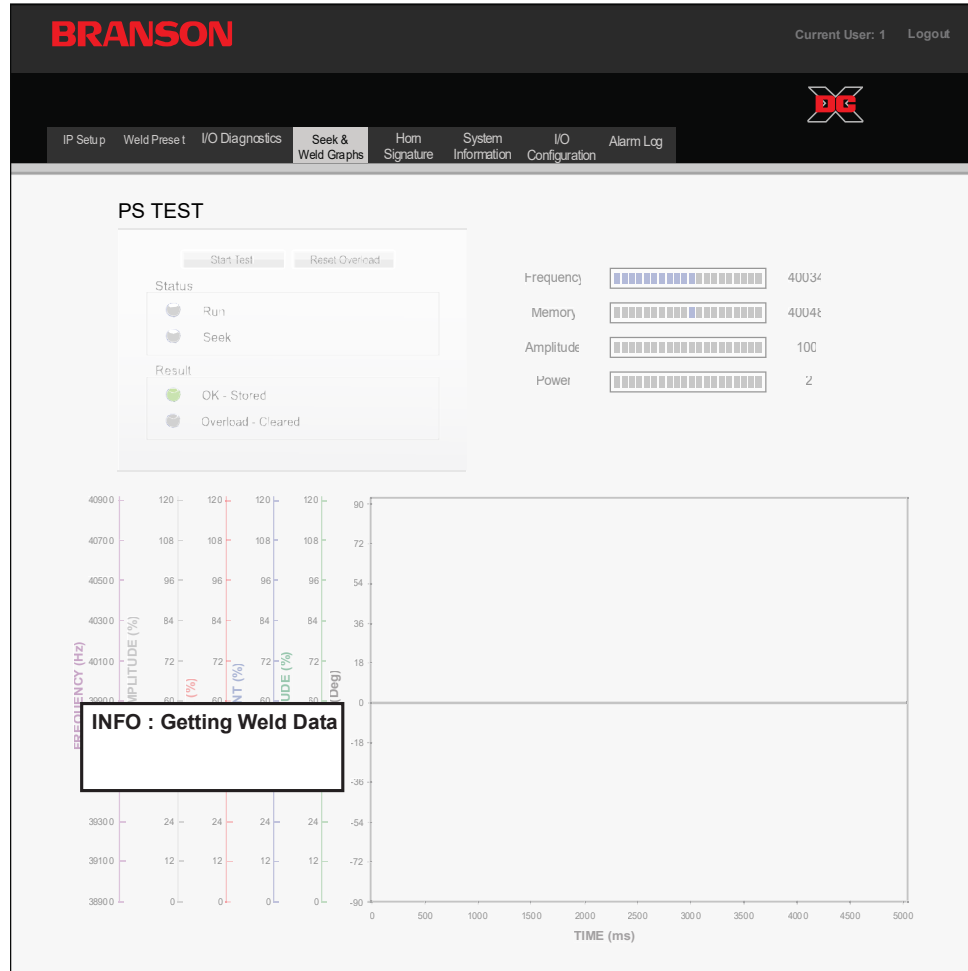
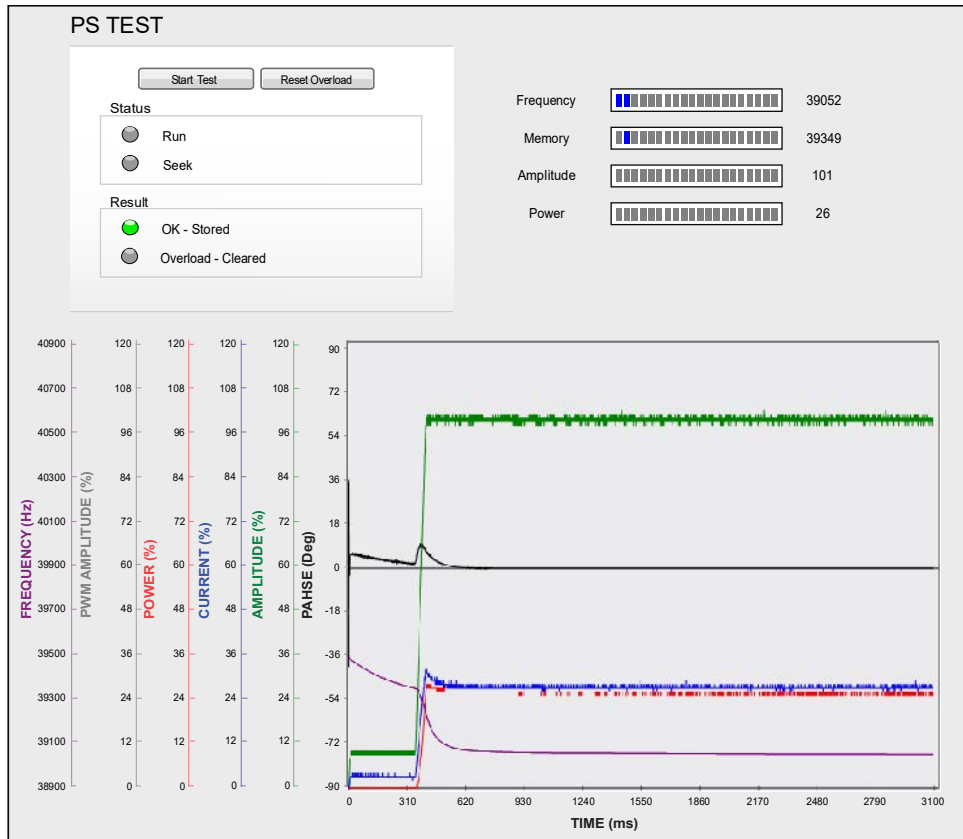

Figure A.9 Graphical Display of the Weld Curves



At the beginning of the process, the frequency is increased until resonance is reached.

At the point of parallel resonance the weld starts. The following happens:

- The amplitude is controlled to the maximum value, and it remains virtually constant
- The phase changes the polarity
- The current increases to the maximum value and then decreases down to a relatively low constant value
- The power output increases and then quickly decreases down to a constant value
- The PWM (Pulse Width Modulation) increases and remains constant

A.5.1 Weld Graph Error Analysis

On the following pages, typical sources of error are shown.

Compare your system's curves with these examples to identify some of the possible problems you may encounter.

Figure A.10 Weld Graph, Defective Horn



This figure resulted in a Overload-Current Alarm.

Figure A.11 Weld Graph, Defective Converter



This figure resulted in a Overload-Current Alarm.

Figure A.12 Weld Graph, Open RF Cable

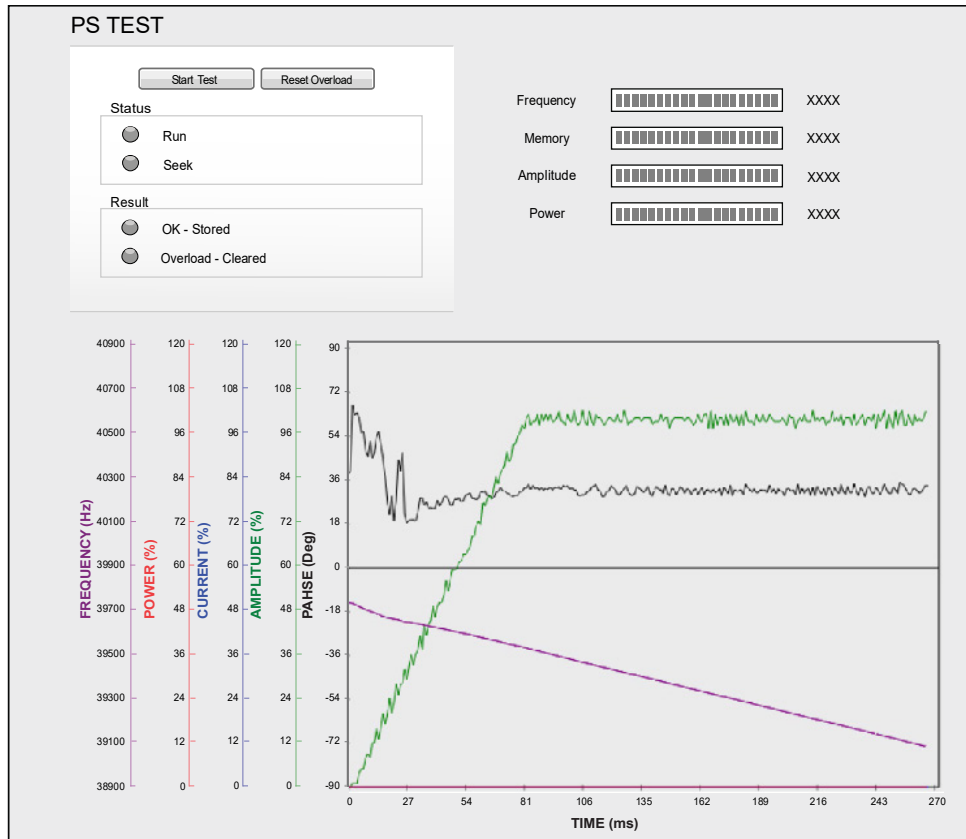

This figure resulted in a Overload-Frequency Alarm.

A.6 DCX Alarms Table

The following table details alarms that you can encounter on the DCX S & V Power Supply. These can be seen in the DCX Web Page Alarm Log Tab.

The message on the Alarm Log Tab is shown on the first column. The second column indicates the condition that led to the alarm. The third and fourth columns indicate the possible cause and the corrective action you should take.

Table A.3 DCX Alarms

Alarm Description	Alarm Condition	Possible Cause	Corrective Action
Overload - Current	During the weld cycle the current exceeded the limit of the Insulated Gate Bipolar Transistor (IGBT) or power semi-conductor device located in the power supply.	Applications that result in High Impact force or that couple at or during the start of the weld are the normal cause of this overload.	<ul style="list-style-type: none"> • Reduce the impact or collision force of the ultrasonic tooling to part. • Reduce the force applied at the start of welding. • Reduce Amplitude. • Increase the power level of the power supply.
Overload - Power Limit	During the weld cycle the safe operation power limit was exceeded causing the power supply to shut down.	The safe power limit was exceeded. By design the power supply will shut down once a limit of 105% of Peak Power is exceeded.	<ul style="list-style-type: none"> • Reduce the force being applied during welding. • Reduce Amplitude. • Increase available power level of the power supply being used. (If available).
Overload - Start Frequency Outside Bandwidth	The starting or resonant frequency of the stack (Converter, Booster, Horn) or combination thereof is outside the safe operating band of the frequency of the power supply.	This can range from a crack in any of the acoustic stack components, to poor interface surfaces of the components. The acoustic tooling has a primary resonant frequency outside the range as defined for operation: 20 kHz (19475 to 20474) 30 kHz (29278 to 30797) 40 kHz (38950 to 40949)	<ul style="list-style-type: none"> • Perform standard stack maintenance by cleaning the interfaces and reassembling the stack. • Remove Horn and test. • Remove and replace booster and test. • Remove and replace converter and test. • If problem persists contact Branson product support and service dept.

Table A.3 DCX Alarms

Alarm Description	Alarm Condition	Possible Cause	Corrective Action
Overload - Temperature	The power supply is operating outside of the recommended safe operating temperature as designed.	The ambient operating temperature of the DCX power supply is + 41° F to + 104° F (+5° C to + 40° C)	<ul style="list-style-type: none">• Be sure the power supply is operating in the stated ambient operating range. It may require additional temperature control to regulate the working environment.

Appendix B: Manual's Revisions

B.1 Manual's Revisions 58

B.1 Manual's Revisions

Refer to the table below for the appropriate manual revision depending on your Power Supply's manufacturing date.

Table B.1 Manual's Revisions

Manual's Revisions	Power Supply's Manufacturing Date	
	From	To
00	April 2022	July 2022
01	August 2022	April 2023
02	May 2023	March 2026
03	April 2026	To date

Figure B.1 Manufacturing date on the Information label



MODEL: 4.00DCXv20HOR
EDP NO.: 101-132-1838
 SERIAL NO.: DJD21064185F

INPUT1:200-240VAC~25A, 50/60Hz 1Ø
 INPUT 2:24VDC 2.5A
 MAX PWR: 4000W

MFG. DATE
June 2021

MADE IN MEXICO

SERIAL NUMBER: XXXXYMM#####



1. Prefix
2. Year of Manufacture
3. Month of Manufacture
4. Incremental Serial Number



Index

A

alarm
DCX alarm table 54
log 35

B

Branson
how to contact 6

C

corrosion 5

E

emissions 5
Ethernet port location 12

H

high voltage 3
how to contact Branson 6

I

inputs
analog 33
digital 33
IP setup 20

M

manual set 9

N

noise 3

O

outputs
analog 34
digital 33

P

pinched 3
Point to Point Connection 14
power supply
default settings (cold start) 21
intended use 5
IP address 20, 21
manual set 9
models 9

- system information 31
- power switch 3
- protective measures 5

R

- resonance 41

S

- safety
 - cable detect 32, 33
 - general precautions 3
 - symbols, meaning 2
- system requirements 13

T

- toxic fumes 5

W

- warranty 6
- web page interface 8, 18
 - Ethernet port location 12
 - IP setup 20
 - login 19
 - setting the weld preset 22
 - system requirements 13
- weld preset, setting 22
- Windows 10 or Windows 11 14