



EMERSONTM

Original Instructions
4000871 - REV. 02



DCX F-EIP Power Supply

Rack Mount Version

Operating Manual

Branson Ultrasonics Corp.
120 Park Ridge Road
Brookfield, CT 06804
(203) 796-0400
<http://www.bransonultrasonics.com>

BRANSON

Manual Change Information

At Branson, we strive to maintain our position as the leader in ultrasonics plastics joining, metal welding, cleaning and related technologies by continually improving our circuits and components in our equipment. These improvements are incorporated as soon as they are developed and thoroughly tested.

Information concerning any improvements will be added to the appropriate technical documentation at its next revision and printing. Therefore, when requesting service assistance for specific units, note the Revision information found on this document, and refer to the printing date which appears on this page.

Copyright and Trademark Notice

Copyright © 2026 Branson Ultrasonics Corporation. All rights reserved. Contents of this publication may not be reproduced in any form without the written permission of Branson Ultrasonics Corporation.

Mylar is a registered trademark of DuPont Teijin Films.

WD-40 is a registered trademark of WD-40 Company.

Windows 10, Windows 11, and Microsoft Edge are registered trademarks of Microsoft Corporation.

Google Chrome is a trademark of Google LLC.

Other trademarks and service marks mentioned herein are held by their respective owners.

Foreword

Congratulations on your choice of a Branson Ultrasonics Corporation system!

The Branson DCX F-EIP Power Supply system is process equipment for the joining of plastic parts using ultrasonic energy. It is the newest generation of product using this sophisticated technology for a variety of customer applications. This Operating Manual is part of the documentation set for this system, and should be kept with the equipment.

Thank you for choosing Branson!

Introduction

This manual is arranged into several structured chapters which will help you find the information you may need to know to safely handle, install, set up, program, operate, and/or maintain this product. Please refer to the [Table Of Contents](#) and/or the [Index](#) of this manual to find the information you may be looking for. In the event you require additional assistance or information, please contact our Product Support department (see [1.3 How to Contact Branson](#) for information on how to contact them) or your local Branson representative.



Table Of Contents

Chapter 1: Safety and Support

1.1	Safety Requirements and Warnings	2
1.2	General Precautions	6
1.3	How to Contact Branson	8
1.4	Returning Equipment for Repair	9
1.5	Obtaining Replacement Parts	12

Chapter 2: Introduction

2.1	Models Covered	14
2.2	Compatibility with other Branson Products	16
2.3	Features	17
2.4	Controls and Indicators	20
2.5	Welding Systems	26
2.6	Glossary	27

Chapter 3: Delivery and Handling

3.1	Shipping and Handling	32
3.2	Receiving	33
3.3	Unpacking the Power Supply	34
3.4	Take Inventory of Small Parts	35
3.5	Returning Equipment	36

Chapter 4: Technical Specifications

4.1	Technical Specifications	38
4.2	Physical Description	41
4.3	EU Declaration of Conformity	42
4.4	UK Declaration of Conformity	43
4.5	Declaration of Conformity to the EtherNet/IP Specification	44

Chapter 5: Installation and Setup

5.1	About Installation	48
5.2	Installation Requirements	49
5.3	Installation Steps	55
5.4	User I/O	58
5.5	Power Supply Setup	74
5.6	Assembling the Acoustic Stack	75
5.7	Converter Cooling	80
5.8	Testing the Installation	82
5.9	Still Need Help?	83

Chapter 6: Converters and Boosters

6.1	Converters and Boosters	86
-----	-----------------------------------	----

Chapter 7: Operation

7.1	Setting Primary Parameters	98
7.2	Setting Limits	109
7.3	Setting the Amplitude	122
7.4	Resetting the Power Supply Alarms	124
7.5	Configuring the Power Supply Registers	125

7.6	Save/Recall Presets	130
7.7	LCD Bar-Graph.	133
7.8	Ultrasonics Test Procedure.	136
7.9	Using the I/O Connections.	138

Chapter 8: EtherNet/IP Operation

8.1	EtherNet/IP	140
8.2	EtherNet/IP Overview	143
8.3	Message Type Definitions	144
8.4	Communication to the CompactLogix Via EtherNet/IP	145
8.5	Implicit Messaging	149
8.6	Explicit Messaging	161
8.7	Implicit Messaging - Control/Status Word	168
8.8	Implicit Messaging Live Channel.	178

Chapter 9: Maintenance

9.1	General Maintenance Considerations.	184
9.2	DCX F-EIP Power Supply Preventive Maintenance.	186
9.3	Recommended Spare Stock	192
9.4	Circuit Diagram	198
9.5	Troubleshooting	199
9.6	Cold Start Procedure.	202

Appendix A: Alarms

A.1	Overload Alarms (Group 0)	204
A.2	Cutoff Alarms (Group 1)	206
A.3	Setup Alarms (Group 2)	207
A.4	Cycle Modified Alarms (Group 3)	208
A.5	Warning Alarms (Group 4).	209
A.6	Limit Alarms (Group 5)	210
A.7	Equipment Failure Alarms (Group 6).	211
A.8	No Cycle Alarms (Group 7)	213
A.9	Communication Failure Alarms (Group 8)	214
A.10	Hardware Alarms (Group A).	215
A.11	Non-Cycle Overload Alarms (Group B)	216
A.12	EIP Standard Error Codes	218

Appendix B: EtherNet/IP Commands

B.1	Parameter Set Class 100 (32 Instances)	220
B.2	Weld Data Class 101 (32 Instances).	223
B.3	Stack Parameter Class 102 (16 Instances)	225
B.4	Common Stack Parameters (16 instances)	226
B.5	Stack Status Class 103 (16 Instances)	227
B.6	Alarm Data Class 104 (1 Instances)	229
B.7	System Information Class 105 (1 Instances)	230
B.8	Other Information Class 112 (1 Instances)	231
B.9	Identity Class 1 (1 Instance)	232

Appendix C: Timing Diagrams

C.1	Timing Diagrams	234
-----	---------------------------	-----

Appendix D: Signal Diagrams

D.1	Signal Diagrams.	246
-----	--------------------------	-----

Appendix E: Manual's Revisions

E.1	Manual's Revisions	250
-----	------------------------------	-----

List Of Figures

Chapter 1: Safety and Support

Figure 1.1	Safety-related Labels found on the DCX F-EIP Power Supply	4
Figure 1.2	Safety-related Labels found on the DCX F-EIP Power Supply	5

Chapter 2: Introduction

Figure 2.1	The DCX F-EIP Power Supply	15
Figure 2.2	DCX F-EIP Power Supply Front Panel Controls and Indicators	20
Figure 2.3	LCD Description	22
Figure 2.4	DCX F-EIP Power Supply Back Panel	25

Chapter 3: Delivery and Handling

Chapter 4: Technical Specifications

Figure 4.1	EU Declaration of Conformity	42
Figure 4.2	UK Declaration of Conformity	43
Figure 4.3	Declaration of Conformity to the EtherNet/IP Specification Page 01	44
Figure 4.4	Declaration of Conformity to the EtherNet/IP Specification Page 02	45

Chapter 5: Installation and Setup

Figure 5.1	DCX F-EIP Power Supply Dimensional Drawing (Small)	50
Figure 5.2	DCX F-EIP Power Supply Dimensional Drawing (Medium)	51
Figure 5.3	DCX F-EIP Power Supply Dimensional Drawing (Large)	52
Figure 5.4	LCD Viewing Angle	56
Figure 5.5	DCX F-EIP Power Supply Connections	57
Figure 5.6	User I/O Cable Identification and Wire Color Diagram	59
Figure 5.7	Typical Digital I/O Wiring Examples	70
Figure 5.8	Typical Analog I/O Wiring Examples	70
Figure 5.9	RF Cable Connection	71
Figure 5.10	Assembling the Acoustic Stack	76
Figure 5.11	Connecting Tip to Horn	79

Chapter 6: Converters and Boosters

Figure 6.1	20 kHz typical Converter Dimensions	86
Figure 6.2	20 kHz Booster Dimensions	87
Figure 6.3	20 kHz Converter/Booster/Horn, Typical Dimensions	88
Figure 6.4	30 kHz Converter Dimensions	89
Figure 6.5	30 kHz Booster Dimensions	90
Figure 6.6	30 kHz Converter/Booster/Horn, Typical Dimensions	91
Figure 6.7	40 kHz Booster Dimensions	92
Figure 6.8	40 kHz Converter/Booster/Horn, Typical Dimensions	93

Chapter 7: Operation

Figure 7.1	Power Window Limits	117
Figure 7.2	LCD at Power Up	122
Figure 7.3	LCD when in External Amplitude Control Mode	123
Figure 7.4	Test Connections	138

Chapter 8: EtherNet/IP Operation

Figure 8.1	LED Status Indicator	140
------------	----------------------	-----

Figure 8.2	I/O Setup for EtherNet/IP Module With Standard Configuration	149
Figure 8.3	RSLogix 5000 Implementation of Token	162
Figure 8.4	Web Page Indication of Token Being Established	162
Figure 8.5	RSLogix 5000 Implementation of Token Release	163
Figure 8.6	Web Page Indication of Token Being Released	163
Figure 8.7	RSLogix 5000 Implementation of Get Energy Value	165
Figure 8.8	RSLogix 5000 Implementation of Set Energy Value.	167
Figure 8.9	PLC Output STW1/STW2 = 0	170
Figure 8.10	PLC Input ZSW1= 16, ZSW2=1024	170
Figure 8.11	DCX Fieldbus Diagnostic	170
Figure 8.12	DCX Weld Mode - Sending a 513 Command - Weld Time.	171
Figure 8.13	DCX Fieldbus Diagnostic Page	171
Figure 8.14	DCX Weld Mode - Sending a 513 Command - Hold Time	172
Figure 8.15	DCX Fieldbus Diagnostic	172
Figure 8.16	DCX Weld Mode - Sending a 0 Command - Changeover State	173
Figure 8.17	DCX Fieldbus Diagnostic Page	173
Figure 8.18	DCX Weld Mode - Sending a 513 Command and Holding It to Create a "Start Input is Active" Alarm	174
Figure 8.19	DCX Fieldbus Diagnostics.	174
Figure 8.20	DCX Weld Mode - Alarm Reset	175
Figure 8.21	DCX Weld Mode - Alarm Reset (Cont)	176
Figure 8.22	DCX Fieldbus Diagnostic	176
Figure 8.23	DCX Weld Mode - Alarm Reset (Cont)	177
Figure 8.24	DCX Fieldbus Diagnostic	177
Figure 8.25	Implicit Messaging	178
Figure 8.26	Data Going to the DCX (Control)	179
Figure 8.27	Data Coming from the DCX (Status)	179
Figure 8.28	DCX Status Word	180
Figure 8.29	Status Word (Web Page Interface)	180
Figure 8.30	DCX Control Word.	181
Figure 8.31	DCX Control Word (Web Page Interface)	181

Chapter 9: Maintenance

Figure 9.1	Reconditioning Stack Mating Surfaces	188
------------	--	-----

Appendix A: Alarms

Appendix B: EtherNet/IP Commands

Appendix C: Timing Diagrams

Figure C.1	Weld Cycle.	234
Figure C.2	Weld Cycle With Overload Alarm and External Reset.	235
Figure C.3	Weld Cycle With Cutoff Alarms and External Reset	236
Figure C.4	Weld Cycle Using Presets.	237
Figure C.5	RF Switching Direct With Feedback With And Without Alarm	238
Figure C.6	RF Switching I/O Direct With Feedback With And Without Alarm.	238
Figure C.7	RF Switching I/O Direct With Feedback With And Without Alarm And Load On Start	239
Figure C.8	RF Switching I/O With Off With And Without Alarm And Load On Start	239
Figure C.9	RF Switching I/O With Off With Feedback With And Without Alarm	240
Figure C.10	RF Switching With Off With Feedback With And Without Alarm	240
Figure C.11	Timing Diagram For All Other Modes With Actuator.	241
Figure C.12	Timing Diagram For Cycle Abort With Actuator.	242
Figure C.13	Timing Diagram For Ground Detect With Actuator.	243

Appendix D: Signal Diagrams

Figure D.1	Continuous Mode	246
Figure D.2	Time Mode.	247

Figure D.3 AE Actuator 248

Appendix E: Manual's Revisions

Figure E.1 Manufacturing date on the Information label. 250

Figure E.2 Location of the Information label on the back of the DCX F-EIP Power Supply. 251



List Of Tables

Chapter 1: Safety and Support

Table 1.1	Branson Contacts	11
-----------	----------------------------	----

Chapter 2: Introduction

Table 2.1	Models Covered in this Manual	14
Table 2.2	Power Supply Compatibility with Branson Converters.	16
Table 2.3	Control Features	17
Table 2.4	DCX F-EIP Power Supply Front Panel Controls and Indicators	20
Table 2.5	LCD Description	22
Table 2.6	Connections to the DCX F-EIP Power Supply.	25
Table 2.7	Glossary.	27

Chapter 3: Delivery and Handling

Table 3.1	Shipping Specifications	32
Table 3.2	Inspect the Power Supply.	33
Table 3.3	Unpacking the Power Supply.	34
Table 3.4	Small Parts included with the Power Supply Assemblies	35
Table 3.5	DCX F-EIP Power Supply System Cables.	35

Chapter 4: Technical Specifications

Table 4.1	Environmental Specifications	38
Table 4.2	Electrical Input Operating Voltages	39
Table 4.3	Input Current and Fuse Specifications	40
Table 4.4	Continuous Duty Maximum Power	40
Table 4.5	Dimensions and Weights of DCX F-EIP Power Supply	41

Chapter 5: Installation and Setup

Table 5.1	Environmental Requirements	53
Table 5.2	Input Current and Circuit Breaker Specifications	53
Table 5.3	DCX F-EIP Power Supply Connections	57
Table 5.4	User I/O Cable Identification and Wire Color Diagram	59
Table 5.5	User I/O Cable Pin Assignments	60
Table 5.6	Default Branson User I/O Connector Pin Assignments	62
Table 5.7	Digital Input Functions.	64
Table 5.8	Digital Output Functions.	66
Table 5.9	Analog Input Functions	68
Table 5.10	Analog Output Functions	69
Table 5.11	RF Cable Connection	71
Table 5.12	Input Power Connection	72
Table 5.13	Power Supply Features.	74
Table 5.14	Acoustic Stack Description	76
Table 5.15	Stack Torque Values	77
Table 5.16	Tools	77
Table 5.17	20 kHz System	78
Table 5.18	30 kHz System	78
Table 5.19	40 kHz System	78
Table 5.20	Tip to horn torque values	79
Table 5.21	Continuous Duty Max. Power & Full Power Duty Cycle	80
Table 5.22	Converter Cooling Procedure.	81

Chapter 6: Converters and Boosters

Table 6.1	20 kHz Converter	86
Table 6.2	20 kHz Booster.	87
Table 6.3	20 kHz Converter/Booster/Horn	88
Table 6.4	30 kHz Converter	89
Table 6.5	30 kHz Booster.	90
Table 6.6	30 kHz Converter/Booster/Horn	91
Table 6.7	40 kHz Booster.	92
Table 6.8	40 kHz Converter/Booster/Horn	93

Chapter 7: Operation

Table 7.1	Summary of Weld Modes	98
Table 7.2	Continuous Mode Operational Sequence	99
Table 7.3	Time Mode Parameters	101
Table 7.4	Time Mode Operational Sequence	101
Table 7.5	Energy Mode Parameters.	103
Table 7.6	Energy Mode Operational Sequence	103
Table 7.7	Peak Power Mode Parameters	105
Table 7.8	Peak Power Mode Operational Sequence	105
Table 7.9	Ground Detect Mode Parameters	107
Table 7.10	Ground Detect Mode Operational Sequence	107
Table 7.11	Time Window Limit High Parameters	109
Table 7.12	Time Window Limit High Operational Sequence	110
Table 7.13	Time Window Limit Low Parameters	111
Table 7.14	Time Window Limit Low Operational Sequence	112
Table 7.15	Energy Window Limit High Parameters	113
Table 7.16	Energy Window Limit High Operational Sequence	114
Table 7.17	Energy Window Limit Low Parameters	115
Table 7.18	Energy Window Limit Low Operational Sequence	116
Table 7.19	Power Window Limit High Parameters	118
Table 7.20	Power Window Limit High Operational Sequence	119
Table 7.21	Power Window Limit Low Parameters	120
Table 7.22	Power Window Limit Low Operational Sequence	121
Table 7.23	Setting the Amplitude Using the Front Panel Controls	122
Table 7.24	Resetting the DCX F-EIP Power Supply	124
Table 7.25	Steps to Configure the Power Supply Registers	125
Table 7.26	Power Supply Registers	127
Table 7.27	Save Preset	130
Table 7.28	Recall Preset	131
Table 7.29	Power Bar-Graph Interpretation Examples	133
Table 7.30	Frequency Bar-Graph Interpretation - 20 kHz (50 Hz Segment)	134
Table 7.31	Frequency Bar-Graph Interpretation - 30 kHz (76 Hz Segment)	134
Table 7.32	Frequency Bar-Graph Interpretation - 40 kHz (100 Hz/Segment)	135
Table 7.33	Frequency Bar-Graph Interpretation Examples	135
Table 7.34	Power Supply Ultrasonic Test Procedure (Front Panel).	137
Table 7.35	Power Supply Ultrasonic Test Procedure (User I/O).	138

Chapter 8: EtherNet/IP Operation

Table 8.1	DCX F-EIP Power Supply LED Status Indicator	140
Table 8.2	DCX Inputs/PLC Outputs (20 words)	149
Table 8.3	Control Word (STW1)	150
Table 8.4	HFS Bit (Control Word)	151
Table 8.5	PSN Bit (Control Word)	151
Table 8.6	Control Word (STW2)	153
Table 8.7	Stack Function	154
Table 8.8	Implicit Message for Reset.	154
Table 8.9	DCX Outputs/PLC Inputs (20 words)	155

Table 8.10	Status Word (ZSW1)	156
Table 8.11	HFS Bit (Status Word)	157
Table 8.12	PSN Bit (Status Word)	157
Table 8.13	Status Word (ZSW2)	159
Table 8.14	Implicit Message for Run	159
Table 8.15	Implicit Message for Seek	160
Table 8.16	Implicit Message for Scan	160
Table 8.17	Getting Token	161
Table 8.18	Attribute ID	161
Table 8.19	Common Services	161
Table 8.20	RSLogix 5000 Implementation of Token	162
Table 8.21	RSLogix 5000 Implementation of Token Release	163
Table 8.22	Get Energy Value Example	164
Table 8.23	Attribute ID	164
Table 8.24	Common Services	164
Table 8.25	RSLogix 5000 Implementation of Get Energy Value	165
Table 8.26	Set Energy Value Example	166
Table 8.27	Attribute ID	166
Table 8.28	Common Services	166
Table 8.29	RSLogix 5000 Implementation of Set Energy Value	167
Table 8.30	Control/Status Word (Time Mode)	168
Table 8.31	DCX Outputs/PLC Inputs (20 words)	168
Table 8.32	DCX Inputs/PLC Outputs (20 words)	169

Chapter 9: Maintenance

Table 9.1	Stack Reconditioning Procedure	187
Table 9.2	Reconditioning Stack Mating Surfaces	188
Table 9.3	Stack Torque Values	189
Table 9.4	Stack Reassembly for a 20 kHz System	189
Table 9.5	Stack Reassembly for a 30 kHz System	190
Table 9.6	Stack Reassembly for a 40 kHz System	190
Table 9.7	Stud Torque Values	191
Table 9.8	DCX F-EIP Power Supply System Cables	192
Table 9.9	Suggested Spares	193
Table 9.10	Converters Compatible with the DCX F-EIP Power Supply	194
Table 9.11	DCX F-EIP Power Supply Compatible Boosters	195
Table 9.12	Other Items used with the DCX F-EIP Power Supply	197
Table 9.13	Troubleshooting	199
Table 9.14	Troubleshooting Common Electrical Problems	199
Table 9.15	Troubleshooting Ultrasonic Power Problems	200
Table 9.16	Troubleshooting Weld Cycle Problems	201
Table 9.17	Steps to Perform a Cold Start	202

Appendix A: Alarms

Table A.1	Overload Alarms (Group 0)	204
Table A.2	Cutoff Alarms (Group 1)	206
Table A.3	Setup Alarms (Group 2)	207
Table A.4	Cycle Modified Alarms (Group 3)	208
Table A.5	Warning Alarms (Group 4)	209
Table A.6	Limit Alarms (Group 5)	210
Table A.7	Equipment Failure Alarms (Group 6)	211
Table A.8	No Cycle Alarms (Group 7)	213
Table A.9	Communication Failure Alarms (Group 8)	214
Table A.10	Hardware Alarms (Group A)	215
Table A.11	Non-Cycle Overload Alarms (Group B)	216
Table A.12	EIP Standard Error Codes	218

Appendix B: EtherNet/IP Commands

Table B.1	Parameter Set Class	220
Table B.2	Common Services	222
Table B.3	Weld Data Class	223
Table B.4	Common Services	224
Table B.5	Stack Parameter Class (Seek Results)	225
Table B.6	Stack Parameter Class (Test Results)	225
Table B.7	Common Services	225
Table B.8	Common Stack Parameters	226
Table B.9	Stack Status Class (Seek)	227
Table B.10	Stack Status Class (Test)	228
Table B.11	Stack Status Class (Scan)	228
Table B.12	Common Services	228
Table B.13	Alarm Data Class	229
Table B.14	Common Services	229
Table B.15	System Information Class	230
Table B.16	Common Services	230
Table B.17	Other Information Class	231
Table B.18	System Configuration Parameters	231
Table B.19	Common Services	231
Table B.20	Identity Class	232
Table B.21	Common Services	232

Appendix C: Timing Diagrams

Appendix D: Signal Diagrams

Appendix E: Manual's Revisions

Table E.1	Manual's Revisions	250
-----------	------------------------------	-----

Chapter 1: Safety and Support





1.1	Safety Requirements and Warnings	2
1.2	General Precautions	6
1.3	How to Contact Branson	8
1.4	Returning Equipment for Repair	9
1.5	Obtaining Replacement Parts	12



1.1 Safety Requirements and Warnings

This chapter contains an explanation of the different Safety Notice symbols and icons found both in this manual and on the product itself and provides additional safety information for ultrasonic welding. This chapter also describes how to contact Branson for assistance.

1.1.1 Symbols Found in this Manual

These symbols used throughout this manual warrant special attention:

WARNING	Indicates a possible danger
	If these risks are not avoided, death or severe injury might result.
WARNING	High Voltage Hazard
	High voltage. Turn power off before servicing.
WARNING	Corrosive Material Hazard
	Corrosive material. Avoid contact with eyes and skin. Wear proper protection.
CAUTION	Indicates a possible danger
	If these risks are not avoided, slight or minor injury might result.

CAUTION	Loud Noise Hazard
	<p>Loud noise hazard. Ear protection must be worn.</p>
CAUTION	Heavy Object
	<p>Heavy object. To avoid muscle strain or back injury, use lifting aids and proper lifting techniques.</p>
NOTICE	Indicates a possible damaging situation
	<p>If this situation is not avoided, the system or something in its vicinity might get damaged.</p> <p>Application types and other important or useful information are emphasized.</p>

1.1.2 Symbols Found on the Product

The DCX F-EIP Power Supply has several safety-related labels on it to indicate the presence of hazardous voltages inside the unit.

Figure 1.1 Safety-related Labels found on the DCX F-EIP Power Supply

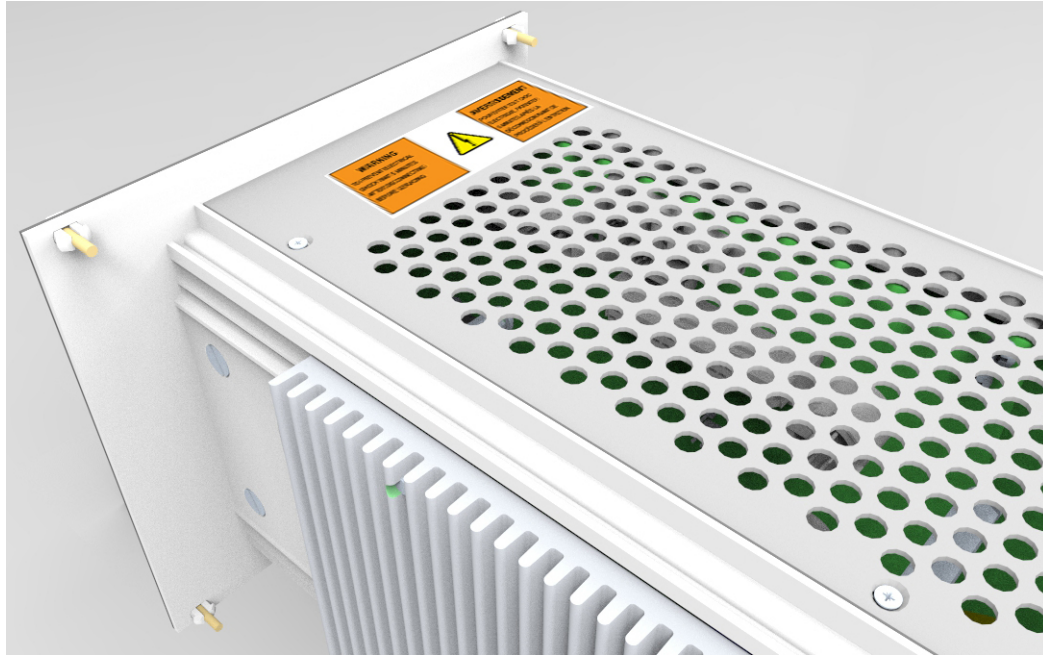

WARNING
TO PREVENT ELECTRICAL SHOCK WAIT 5 MINUTES AFTER DISCONNECTING BEFORE SERVICING



AVERTISSEMENT
POUR ÉVITER TOUT CHOC ÉLECTRIQUE, PATIENTER 5 MINUTES APRÈS LA DÉCONNEXION AVANT DE PROCÉDER À L'ENTRETIEN.

Figure 1.2 Safety-related Labels found on the DCX F-EIP Power Supply



1.2 General Precautions

Take the following precautions before servicing the power supply:

- Be sure the power is disconnected before making any electrical connections
- To prevent the possibility of an electrical shock, always plug the power supply into a grounded power source
- To prevent the possibility of an electrical shock, ground the power supply by securing an 8 gauge grounded conductor to the ground screw located next to the air outlet
- Power supplies produce high voltage. Before working on the power supply assembly, do the following:
 - Turn off the power supply
 - Unplug main power
 - Allow at least 5 minutes for capacitors to discharge
- High voltage is present in the power supply. Do not operate with the cover removed
- High line voltages exist in the ultrasonic power supply assembly. Common points are tied to circuit reference, not chassis ground. Therefore, use only non-grounded, battery-powered multimeters when testing the power supply assembly. Using other types of test equipment can present a shock hazard
- Keep hands from under the horn. Down force (pressure) and ultrasonic vibrations can cause injury
- Do not cycle the welding system if either the RF cable or converter is disconnected
- When using larger horns, avoid situations where fingers could be pinched between the horn and the fixture
- Ensure power supply installation is performed by qualified personnel and in accordance with local standards and regulations

CAUTION	Loud Noise Hazard
	<p>Sound level and frequency of the noise emitted during the ultrasonic assembly process may depend upon a. type of application, b. size, shape and composition of the material being assembled, c. shape and material of the holding fixture, d. welder setup parameters and e. tool design.</p> <p>Some parts vibrate at an audible frequency during the process. Some or all of these factors may result in an uncomfortable noise being emitted during the process.</p> <p>In such cases operators may need to be provided with personal protective equipment. See 29 CFR (Code of Federal Regulations) 1910.95 Occupational Noise Exposure.</p>

1.2.1 Intended Use of the System

The DCX F-EIP Power Supply and components are designed to be used as part of an ultrasonic welding system. These are designed for a wide variety of welding or processing applications.

If the equipment is used in a manner not specified by Branson, the protection provided by the equipment may be impaired.

Branson Ultrasonics Corporation designs and manufactures machines giving the first priority to safety precautions, to allow customers to use the machines safely and effectively. Only trained operators should run and service the equipment. Untrained operators can misuse the equipment or ignore safety instructions that can result in personal injury or equipment damage. It is most essential that all operators and service

personnel pay attention to safety instructions when operating and servicing the equipment.

1.2.2 Emissions

Because of the various types of toxic or injurious gases that may be liberated during the welding based on the material being processed, sufficient ventilation should be provided to prevent a concentration of these gases in excess of 0.1 ppm. Check with your materials suppliers for recommended protection when processing their materials.

CAUTION	Corrosive Material Hazard
	<p>Processing of many materials, such as PVC, can be hazardous to an operator's health and could cause corrosion/damage to the equipment. Use proper ventilation and take protective measures.</p>

NOTICE	
	<p>When the battery is worn out, dispose it under the ordinance of each local government.</p>

WARNING	Corrosive Material Hazard
	<p>First aid measures (in case of electrolyte leakage from the battery):</p> <p>Eye Contact: Flush the eyes with plenty of clean water for at least 15 minutes immediately, without rubbing. Get immediate medical treatment. If appropriate procedures are not taken, this may cause eye injury.</p> <p>Skin Contact: Wash the affected area under tepid running water using a mild soap. If appropriate procedures are not taken, this may cause sores on the skin. Get medical attention if irritation develops or persists.</p> <p>Inhalation: Remove to fresh air immediately. Get medical treatment immediately.</p>

1.2.3 Setting up the Workplace

Measures for setting up a workplace for safe operation of the ultrasonic welder are outlined in [Chapter 5: Installation and Setup](#).

1.2.4 Regulatory Compliance

This product meets electrical safety requirements and EMC (Electromagnetic Compliance) requirements for North America, Great Britain, and the European Union.

1.3 How to Contact Branson

Branson is here to help you. We appreciate your business and are interested in helping you successfully use our products. To contact Branson for help, use the following telephone numbers, or contact the field office nearest you (business hours from 8 a.m. to 4 p.m. Central and Eastern Time Zones):

- **North American Headquarters (all Departments):** (203) 796-0400
- **Parts Store (direct number):** (877) 330-0406
- **Repair department:** (877)-330-0405
- **For emergency after-hours service (5 p.m. – 8 a.m. EST):** (203) 796-0500 (US phone numbers only)

Tell the operator which product you have and which person or department you need ([Table 1.1 Branson Contacts](#)). If after hours, please leave a voice message with your name and return telephone number.

1.3.1 Before Calling Branson for Assistance

This manual provides information for troubleshooting and resolving problems that could occur with the equipment (see [Chapter 9: Maintenance](#)). If you still require assistance, Branson Product Support is here to help you. To help identify the problem, use the following questionnaire which lists the common questions you will be asked when you contact the Product Support department.

Before calling, determine the following information:

1. Your company name and location.
2. Your return telephone number.
3. Have your manual with you. If troubleshooting a problem, refer to [Chapter 9: Maintenance](#).
4. Know your equipment model and serial numbers (found on a gray data label on the units). Information about the horn (part number, gain, etc.) or other tooling may be etched into the tooling. Software- or firmware-based systems may provide a BOS or software version number, which may be required.
5. What tooling (horn) and booster are being used?
6. What are the setup parameters and mode?
7. Is your equipment in an automated system? If so, what is supplying the "start" signal?
8. Describe the problem; provide as much detail as possible. For example, is the problem intermittent? How often does it occur? How long before it occurs if you are just powering up? If an error is occurring, which error (give error number or name)?
9. List the steps you have already taken.
10. What is your application, including the materials being processed?
11. Have a list of service or spare parts you have on hand (tips, horns, etc.)
12. Notes:

1.4 Returning Equipment for Repair

Before sending equipment for repair, provide as much information with the equipment to help determine the problem with the system. Use the following page to record necessary information.

NOTICE	
	<p>To return equipment to Branson, you must first obtain an RGA number from a Branson representative, or the shipment may be delayed or refused.</p>

If you are returning equipment to Branson for repair, you must first call the Repair department to obtain a **Returned Goods Authorization** (RGA) number. (If you request it, the repair department will fax a Returned Goods Authorization form to fill out and return with your equipment).

Branson Repair Department, C/O Zuniga Logistics, LTD

12013 Sara Road, Killam Industrial Park

Laredo, Texas 78045 U.S.A.

Direct telephone number: (877) 330-0405

Fax number: (877) 330-0404

- Provide as much information as possible that will help identify the need for repair
- Carefully pack the equipment in original packing cartons
- Clearly label all shipping cartons with the RGA number on the outside of cartons as well as on your packing slip, along with the reason for return
- Return general repairs by any convenient method. Send priority repairs by air freight
- You must prepay the transportation charges FOB Laredo, Texas, U.S.A.

1.4.1 Get an RGA Number

RGA#

If you are returning equipment to Branson, please call the Repair Department to obtain a Returned Goods Authorization (RGA) number. (At your request, the Repair Department will fax an RGA form to fill out and return with the equipment.)

1.4.2 Record Information About the Problem

Before sending equipment for repair, record the following information and send a copy of it with the equipment. This will greatly increase Branson's ability to address the problem.

1. Describe the problem; provide as much detail as possible. For example, is the problem intermittent? How often does it occur? How long before it occurs after powering up?

2. Is your equipment in an automated system?

3. If the problem is with an external signal, which signal?

4. If known, include plug/pin # (e.g., P29, pin #3) for that signal:

5. What are the Weld Parameters?

6. What is your application? (Type of weld, plastic material, etc.):

7. Name and phone number of the person most familiar with the problem:

Contact the Branson office prior to shipping the equipment.

For equipment not covered by warranty, to avoid delay, include a Purchase Order.

Send a copy of this page with the equipment being returned for repair.

1.4.3 Departments to Contact

Call your local Branson Representative, or contact Branson by calling and asking for the appropriate department, as indicated in [Table 1.1 Branson Contacts](#) below.

Table 1.1 Branson Contacts

What you need help with or information about	Whom to Call	At this Phone Number...
Information about new welding systems or components	Your local Branson Rep or Branson Customer Service	203-796-0400 Ext 384
Application and setup questions on the welding system	Welding Applications Lab	203-796-0400 Ext 368
Application assistance on the horns and tooling	ATG Lab	203-796-0400 Ext 495
Technical questions about the welding system	Welding Product Support	203-796-0400 Ext 355, 551
Technical questions about horns and tooling	ATG Lab	203-796-0400 Ext 495
Ordering new parts	Parts Store	877-330-0406
RGA's, request for repair, status of a repair	Welding Repair Department	877-330-0405
System automation/hookup information	Product Support	203-796-0400 Ext 355, 551

My Local Branson Representative's name is:

I can reach this representative at:

1.4.4 Pack and Ship the Equipment

- Carefully pack the system in original packing material to avoid shipping damage. Plainly show the RGA number on the outside of cartons as well as inside the carton along with the reason for return. Make a list of all components packed in the box. KEEP YOUR MANUAL.
- Return general repairs by any convenient method. Send priority repairs by air freight. Prepay the transportation charges FOB the repair site.

NOTICE	
	Items that are sent Freight Collect will be refused.

1.5 Obtaining Replacement Parts

You can reach Branson Parts Store at the following telephone numbers:

Branson Part Store

Direct telephone number: 877-330-0406

Fax number: 877-330-0404

Many parts can be shipped the same day if ordered before 2:30 p.m., Eastern time.

A parts list is found in [Chapter 9: Maintenance](#) of this manual, listing descriptions and EDP part numbers. If you need replacement parts, coordinate the following with your purchasing agent:

- Purchase order number
- Ship to information
- Bill to information
- Shipping instructions (air freight, truck, etc.)
- Any special instructions (for example, "Hold at the airport and call"). Be sure to give a name and phone number
- Contact name information

Chapter 2: Introduction

2.1	Models Covered	14
2.2	Compatibility with other Branson Products	16
2.3	Features	17
2.4	Controls and Indicators	20
2.5	Welding Systems	26
2.6	Glossary	27

2.1 Models Covered

This manual covers all models of the DCX F-EIP Power Supply.

Table 2.1 Models Covered in this Manual

Frequency	Power	EDP
20 kHz	1250 W	101-132-2062
	2500 W	101-132-2063
	4000 W	101-132-2064
30 kHz	1500 W	101-132-2061
40 kHz	800 W	101-132-2060

2.1.1 Overview of these Models

Figure 2.1 The DCX F-EIP Power Supply



The DCX F-EIP Power Supply generates ultrasonic energy through an ultrasonic converter for welding plastics. Several models are available, depending on the desired frequency (for example, 20 kHz) and the desired power range (for example, 4.0 kW). The power supply also contains a microprocessor-based controller module that provides for control and monitoring of welding operations.

The power supply provides the following features:

End of Weld Store: Allows the power supply to track and store the frequency of the last weld.

Timed Seek: Tracks and starts the stack on the correct frequency. It does this by running the horn at a low-level amplitude (10%) to find and lock on to the stack operating frequency. Seeks are timed from the moment sonics was last activated.

Line Regulation: Maintains converter amplitude by regulating for variances in the line voltages.

Load Regulation: Maintains converter amplitude over the full range of rated power.

System Protection: Protects the power supply by providing six levels of protection.

- Voltage
- Current
- Phase
- Temperature
- Power
- Frequency

Web Page Interface: Provides access, via Ethernet connection, to power supply information, diagnostics, and configuration web pages.

2.2 Compatibility with other Branson Products

Table 2.2 Power Supply Compatibility with Branson Converters

DCX F-EIP Models	Converter
20 kHz	CR-20S
	CR-20C
	CH-20S (932 AH SPL)
	CH-20C
	CS-20S
	CS-20C
30 kHz	CR-30S
	CR-30C
	CH-30S
	CH-30C
	CS-30S
	CS-30C
40 kHz	CR-40S (4TH)
	CR-40C
	4TP

2.3 Features

2.3.1 The Welding System

The welding system consists of a DCX F-EIP Power Supply and a converter-booster-horn stack. The system can perform ultrasonic welding, inserting, staking, spot welding, swaging, degating, and continuous ultrasonic operations. It is designed for automated, semi-automated and/or manual production operations.

2.3.2 The Power Supply

The DCX F-EIP Power Supply consists of an ultrasonic power supply assembly with a system controller and user interfaces. The ultrasonic power supply assembly converts conventional 50/60 Hz line current to 20 kHz, 30 kHz or 40 kHz electrical energy. The system controller controls the welding system.

Listed below are the control features of the Branson DCX F-EIP Power Supply ultrasonic welding system:

Table 2.3 Control Features

Name	Description
Autotuning	Branson power supply tuning ensures that the system is running at peak efficiency.
Digital Amplitude Setting	This feature allows you to set the exact amplitude necessary for your application, allowing increased range and setting repeatability over analog systems.
EtherNet/IP	Provides plant-wide network systems using open, industry-standard networking technologies. This combination of well-accepted standards provides the functionality required to support both information data exchange as well as control applications.
Frequency Offset	This process feature allows a user to set an offset relative to the starting frequency, for certain specific applications, where the force imparted on the fixture or anvil causes a frequency shift in the stack's operation. You should only use this feature when advised to do so by Branson.
Horn Signature	Using the DCX F-EIP Power Supply Web Page Interface, you may scan your ultrasonic stack to view its operating frequency on your computer, using digital readouts to give you the best picture of the stack's operation.
LCD (Liquid Crystal Display)	Provides a clear visual interface to monitor and configure the system.
Line Regulation	Maintains converter amplitude by regulating for variances in the line voltages.
Load Regulation	Maintains converter amplitude over the full range of rated power.
Membrane Keys	Front panel controls are designed for high reliability and immunity from factory dust and oils.
Ramp Starting	The starting of the DCX F-EIP Power Supply and horn is done at a rate that helps reduce electrical and mechanical stress on the system. The horn start rate may be adjusted for some tough-to-start applications.

Table 2.3 Control Features

Name	Description
Seek	Ensures operation at resonance; minimizes tuning errors; and operates the stack at low amplitude (10%), then provides a means of sensing and storing the resonant operating frequency value.
Start-up Diagnostics	At start-up, the controls test the major internal components.
System Protection	Protects the power supply by providing six levels of protection: voltage, current, phase, temperature, power, and frequency.
Timed Seek	When enabled, will do a Seek once every minute to update horn resonant frequency to memory. This is especially useful when the welding process affects the actual temperature of the horn, causing a resonant frequency shift.
True Watt-meter	The controls on the power supply include a true watt-meter for accurate measurement of power and energy.
User ID and Passcodes	Allows for keeping track of user access to the DCX F-EIP Power Supply Web Page Interface.
Web Page Interface	Provides access, via Ethernet connection, to power supply information, diagnostics, and configuration web pages.

2.3.3 The Actuator

The DCX F-EIP Power Supply can interface with actuator signals, only when operating in manual mode.

2.3.4 Converter/Booster/Horn Assembly

The Converter

The ultrasonic electrical energy from the power supply is applied to the converter (sometimes called the transducer). This transforms the high frequency electrical oscillations into mechanical vibrations at the same frequency as the electrical oscillations. The heart of the converter is piezoelectric ceramic elements. When subjected to an alternating voltage, these elements alternately expand and contract, resulting in better than 90% conversion of electrical to mechanical energy.

The Booster

Success in ultrasonic assembly depends on the right amplitude of movement at the horn face. Amplitude is a function of horn shape, which is largely determined by the size and form of the parts to be assembled. The booster can be used as a mechanical transformer to increase or decrease the amplitude of vibrations applied to the parts through the horn.

The booster is a resonant half-wave section of aluminum or titanium. It is mounted between the converter and the horn, as part of the ultrasonic stack. It also provides a clamping point for rigid stack mounting.

Boosters are designed to resonate at the same frequency as the converter with which they are used. Boosters are usually mounted at a nodal (minimum vibration) point of axial motion. This minimizes the loss of energy and prevents vibration from being transmitted to the stack supporting structure.

The Horn

The horn is selected or designed for a specific application. Each horn is tuned typically as a half-wave section that applies the necessary force and vibration uniformly to the parts to be assembled. It transfers ultrasonic vibrations from the converter to the workpiece. The horn is mounted to the booster as part of the ultrasonic stack.

Depending on their profile, horns are referred to as stepped, conical, exponential, bar, or catenoidal. The shape of the horn determines the amplitude at the face of the horn. Depending on the application, horns can be made from titanium alloys, aluminum, or steel. Titanium alloys are the best materials for horn fabrication due to their high level of strength and low loss. Aluminum horns are usually chrome- or nickel-plated or hard-coated to reduce wear. Steel horns are for low amplitude requiring hardness, such as ultrasonic insertion applications.

2.4 Controls and Indicators

2.4.1 DCX F-EIP Power Supply Front Panel

Figure 2.2 DCX F-EIP Power Supply Front Panel Controls and Indicators

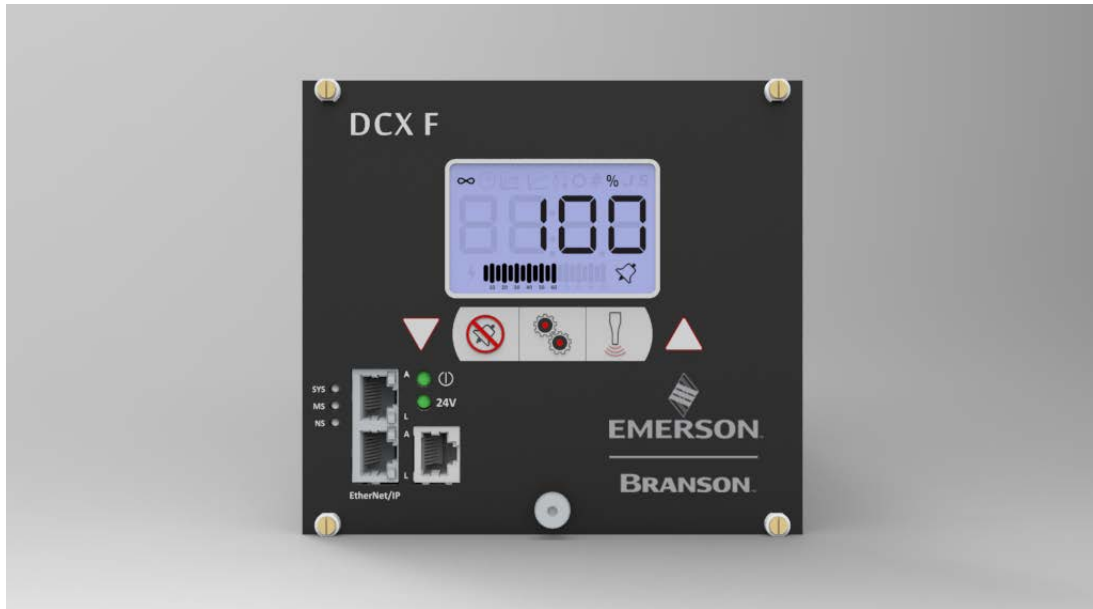

Table 2.4 DCX F-EIP Power Supply Front Panel Controls and Indicators



Reference	Description
	<p>LCD</p> <p>For detailed information refer to Figure 2.3 LCD Description and Table 2.5 LCD Description.</p>
	<p>Up/Down Keys</p> <p>Use to adjust the amplitude of ultrasonic vibrations (10% to 100%). Also used to adjust weld mode parameters, select registers and edit register values.</p>
	<p>Alarm Reset Key</p> <p>Use the Reset key to reset alarms.</p> <p>When changing system registers, use the Reset key to set a register back to its default value after entering the register and before editing the value.</p>

Table 2.4 DCX F-EIP Power Supply Front Panel Controls and Indicators



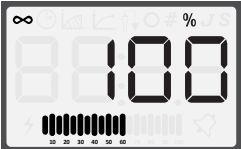

Reference	Description
	<p>Configuration Key</p> <p>Use the Configuration key to change system registers. For information on using the Configuration key to set system registers see 7.5 Configuring the Power Supply Registers.</p>
	<p>Ultrasonics Test Key</p> <p>Use the Test key to perform an ultrasonic test. Test performs a seek and then ramps the amplitude to the current setting.</p>
	<p>EtherNet/IP Connectors</p> <p>Use the EtherNet/IP Connector to connect the DCX F-EIP Power Supply to a master/slave EtherNet/IP network. For more information, refer to Chapter 5: Installation and Setup and Chapter 7: Operation.</p>
	<p>Ethernet Port</p> <p>Use the Ethernet Port to connect to the DCX F-EIP Power Supply Web Page Interface.</p>
	<p>Power-On Indicator</p> <p>Lights when the power supply is connected to main power and the power is on.</p>
	<p>24 V Indicator</p> <p>Lights when 24 V DC are supplied to the DCX F-EIP Power Supply.</p>
	<p>EtherNet/IP Status Indicator</p> <p>Indicate the status of the EtherNet/IP module. For more information see Chapter 7: Operation.</p>

Figure 2.3 LCD Description

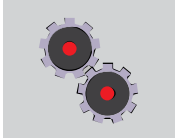
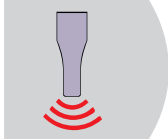
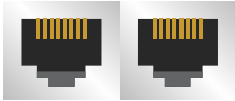
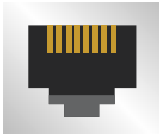
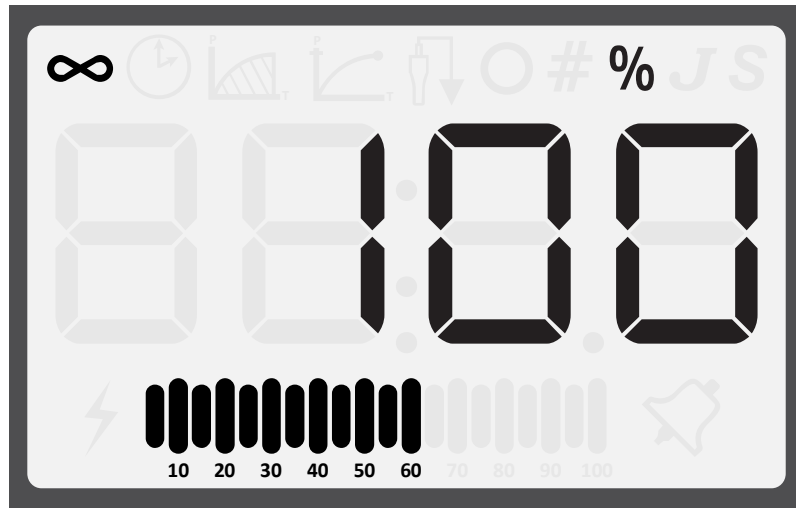

Table 2.5 LCD Description



Reference	Description
	<p>Numeric Display</p> <p>Displays the Power Supply amplitude settings, weld time settings, weld energy settings, peak power settings, scrub time settings, register numbers, register values or alarm numbers.</p>
	<p>Continuous Mode Icon</p> <p>Indicates the power supply is running in Continuous mode. When in Continuous mode, the amplitude setting is shown on the numeric display in conjunction with the % icon. The amplitude setting may range from 10% to 100%. For more information see Chapter 7: Operation.</p>
	<p>Time Mode Icon</p> <p>Indicates the power supply is running in Time mode. When in Time mode, the weld time setting is shown on the numeric display in conjunction with the S icon. The weld time setting can range from 10 ms to 30 seconds. For more information see Chapter 7: Operation.</p>
	<p>Energy Mode Icon</p> <p>Indicates the power supply is running in Energy mode. When in Energy mode, the weld energy setting is shown on the numeric display in conjunction with the J icon. The energy setting may range from 1 Joule to 9999 Joules. For more information see Chapter 7: Operation.</p>

Table 2.5 LCD Description





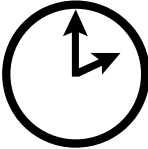
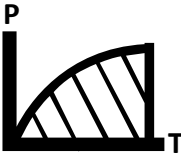

Reference	Description
	<p>Peak Power Icon</p> <p>Indicates the power supply is running in Peak Power mode. When in Peak Power mode, the peak power percentage is shown on the numeric display in conjunction with the % icon. The peak power setting may range from 1% to 100% of the maximum power supply output power. For more information see Chapter 7: Operation.</p>
	<p>Ground Detect Icon</p> <p>Indicates the power supply is running in Ground Detect mode. When in Ground Detect mode, the scrub time setting will be shown on the numeric display in conjunction with the S icon. Scrub time setting may range from 1 millisecond to 500 milliseconds. For more information see Chapter 7: Operation.</p>
	<p>Sonics Active Indicator</p> <p>Indicates ultrasonics is running.</p>
	<p>Time Icon</p> <p>Indicates that the value shown on the numeric display represents time in seconds.</p>
	<p>Joule Icon</p> <p>Indicates that the value shown on the numeric display represents energy.</p>
	<p>Percentage Icon</p> <p>Indicates that the value shown on the numeric display represents a percentage. When in Peak Power mode, the value shown on the numeric display represents a percentage of the power supply rated power. If not in Peak Power mode, the value shown on the numeric represents the amplitude setting.</p>
	<p>Number Sign Icon</p> <p>Indicates that the value shown on the numeric display is a register number. Use up and down keys to select a register. For more information see 7.5 Configuring the Power Supply Registers.</p>

Table 2.5 LCD Description

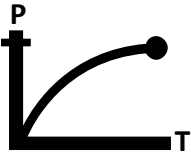
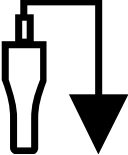
Reference	Description
	<p>Circle Icon</p> <p>Indicates that the value shown on the numeric display is a register value. Use up and down keys to modify the register value. For more information see 7.5 Configuring the Power Supply Registers.</p>
	<p>Alarm Icon</p> <p>A flashing icon which indicates and alarm condition.</p>
	<p>Power/Frequency Bar-Graph</p> <p>Shows the true percentage of ultrasonic power during a weld cycle. The bar-graph can be configured to show the peak power or the memory frequency at the end of each weld or test cycle. For instructions on how to modify this setting see 7.5 Configuring the Power Supply Registers.</p> <p>For detailed bar-graph description and bar-graph reading examples, see 7.7.1 Power Bar-Graph Interpretation and 7.7.2 Frequency Bar-Graph Interpretation.</p>

2.4.2 DCX F-EIP Power Supply Connections

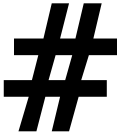
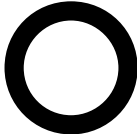
Figure 2.4 DCX F-EIP Power Supply Back Panel

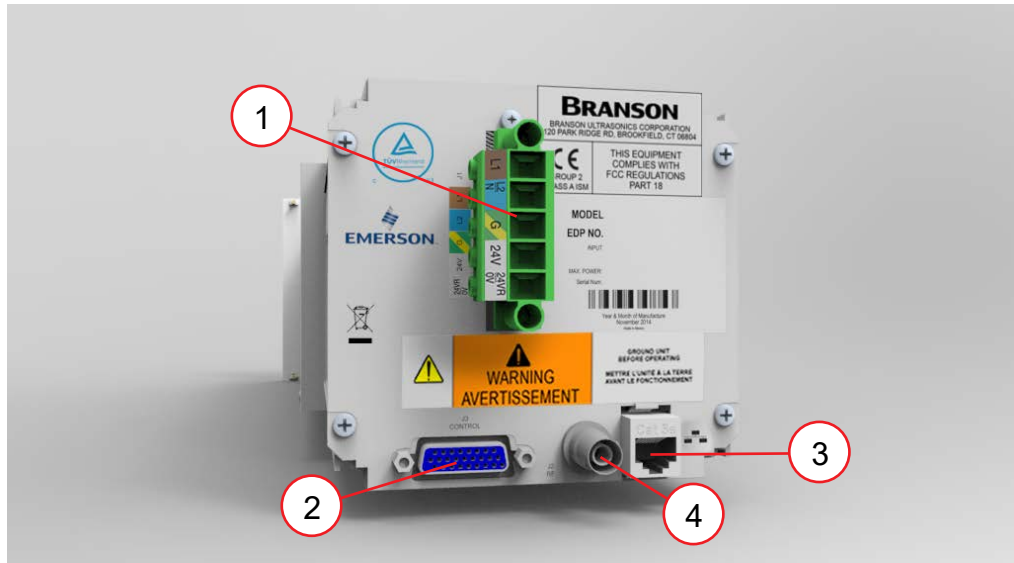

Table 2.6 Connections to the DCX F-EIP Power Supply

Item	Name	Function
1	Line Input Connector	Detachable connector block for connecting the input power. For wiring details refer to Chapter 5: Installation and Setup .
2	User I/O Connector	Provides the necessary input/output signals to interface with actuators, user automation or control interfaces. For detailed information on interfacing with the DCX F-EIP Power Supply refer to Chapter 5: Installation and Setup .
3	Ethernet Port	Use the Ethernet Port to connect to the DCX F-EIP Power Supply Web Page Interface.
4	RF Connector	SHV connector for RF cable, which provides ultrasonic energy to the converter.

2.5 Welding Systems

2.5.1 Principle of Operation

Thermoplastic parts are welded ultrasonically by applying high frequency vibrations to the parts being assembled. The vibrations, through surface and intermolecular friction, produce a sharp rise in temperature at the welding interface.

When the temperature is high enough to melt the plastic, there is a flow of material between the parts. When the vibrations stop, the material solidifies under pressure and a weld results.

2.5.2 Weld System Applications

DCX F-EIP Power Supply weld systems can be used for the following applications:

- Ultrasonic welding
- Cutting and sealing thermoplastic fabric and film
- Staking, spot welding, swaging, and degating thermoplastic parts
- Other ultrasonic processing applications

2.6 Glossary

The following terminology may be encountered when using or operating a DCX F-EIP Power Supply ultrasonic welding system:

Table 2.7 Glossary

Name	Description
Actuator	The unit which houses the converter/booster/horn stack assembly in a rigid mounting, allowing the stack to move up and down, either mechanically or pneumatically, applying force to the part at a user-adjustable force and velocity.
Alarm	Visual indication of error.
Amplitude	The peak-to-peak movement at the horn face. Always expressed as a percentage of the maximum.
Amplitude Control	The ability to set amplitude digitally or by an external control.
Booster	A one-half-wavelength-long resonant metal section mounted between the converter and horn, sometimes having a change in cross-sectional area between the input and output surfaces. The booster mechanically alters the amplitude of vibrations received from the converter, and imparts the new amplitude to the horn.
Clamping Force	The pounds or kilograms exerted by the horn onto the workpiece.
Cold Start	Restores the settings of the power supply back to its original condition.
Converter	The device that converts electrical energy into mechanical vibrations at a high frequency (an ultrasonic rate).
Counters	A record of the number of preset cycles recorded in the power supply.
Degating	Removing a molded part from its runner system.
Energy Director	A triangular-shaped projection of plastic material which concentrates the ultrasonic energy at the joint interface of a plastic part.
External Amplitude Control	Enables you to access real-time amplitude control directly via the user I/O connector.
External Frequency Control	Enables you to access real-time frequency offset control directly via the user I/O connector.
Fieldbus	Computer network protocols for industrial two way communications used for real-time distributed control.
Fixture	A device for holding a part in position for assembly.
Flash	Material displaced from the joint area.
Forming	Reshaping a section of thermoplastic.
Frequency	The operating frequency of the ultrasonic stack. The frequency stored is measured at the end of the ultrasonic portion of the cycle (when ultrasonics are terminated).

Table 2.7 Glossary

Name	Description
Frequency Offset	An offset factor applied to the ultrasonic frequency stored in the power supply.
Fretting Corrosion	A black surface condition, that results from friction between metal parts, that appears on the converter-booster-horn stack mating surfaces.
Gain	The ratio of output to input amplitude of a horn or booster.
Horn	A bar or metal section, usually one half-wavelength-long which transfers vibratory energy to the workpiece.
Horn Amplitude	The peak-to-peak displacement of a horn at its work face.
Horn Signature	A scan to enhance selection of operating frequency and control parameters.
Insertion	The process of embedding a metal component in plastic.
Interface	<ol style="list-style-type: none"> 1. The contact surface of two mating parts. 2. The connection between two pieces of equipment.
Joint	The weld surfaces.
Parameter	A unique factor or element which affects the welding operation in a particular mode.
Parameter Range	Valid range of parameters accepted for a particular setup.
Power Supply	The electronic instrument in an ultrasonic assembly system which changes conventional 50/60 Hz electrical power into high frequency electrical power at 20 kHz, 30 kHz or 40 kHz.
Seek	The activation of ultrasonics at a low-level (10%) amplitude, for the purpose of finding the resonant frequency of the stack.
Staking	The process of melting and reforming a plastic stud to mechanically lock a dissimilar material in place.
Swaging	The process of capturing another component of an assembly by melting and reforming a ridge of plastic.
Thermoplastic	A polymer which undergoes a reversible change of state when subjected to heat.
Thermoset	A polymer which undergoes an irreversible change when subjected to heat.
Token	Token is a concept that applies to who can make a change to the preset. If the fieldbus has gotten the token, then only the fieldbus can perform a change. However, if fieldbus has not gotten the token (or has released the token), then the preset can be changed by any other means, for example, via Web Page or front panel controls.
Ultrasonic Power	Presence of ultrasonic power at the horn face.

Table 2.7 Glossary

Name	Description
Ultrasonic Welding	The use of ultrasonic vibrations to generate heat and subsequently melt the mating surfaces of two thermoplastic parts. When ultrasonic vibrations stop, the molten material resolidifies, and a weld occurs.
User ID	A unique 12 character long alphanumeric ID used to keep track of user access to the web page interface.
Weld System	A combination of components required to perform an ultrasonic operation. Usually consists of a power supply, converter, booster, and horn, with either an actuator or a handheld device, or in a fixed, mounted location.



Chapter 3: Delivery and Handling

3.1	Shipping and Handling	32
3.2	Receiving	33
3.3	Unpacking the Power Supply	34
3.4	Take Inventory of Small Parts	35
3.5	Returning Equipment	36

3.1 Shipping and Handling

CAUTION	Heavy Object
	<p>The power supply may be heavy. Handling, unpacking, and installation may require the assistance of a colleague or the use of lifting platforms or hoists.</p>

3.1.1 Environmental Specifications

The DCX F-EIP Power Supply is an electronic unit that converts line voltage to ultrasonic energy and responds to user input for regulating the weld process. Its internal components are sensitive to static discharge, and many of its components can be harmed if the unit is dropped, shipped under improper conditions, or otherwise mishandled.

The following environmental guidelines should be respected in the shipping of the power supply.

Table 3.1 Shipping Specifications

Environmental Condition	Acceptable Range
Storage / Shipping Temperature	-25° C / -13° F to +55° C / +131° F (+70° C / +158° F for 24 hours)
Shock / Vibration (transit)	45 g shock / 0.5 g and (3 to 100 Hz) vibration per ASTM 3332-88 and 3580-90
Drop Test	ISTA Procedure 1 & 2A (while packaged)
Humidity	Maximum 95%, non-condensing

3.2 Receiving

The DCX F-EIP Power Supply is a sensitive electronic device. Many of its components can be harmed if the unit is dropped or otherwise mishandled.

Scope of Delivery

Branson equipment is carefully checked and packed before dispatch. It is recommended, however, that you follow the procedure below upon receiving your DCX F-EIP Power Supply.

Inspect the Power Supply when it is delivered, take the following steps:

Table 3.2 Inspect the Power Supply

Step	Action
1	Verify that all parts are complete according to the packing slip.
2	Check the packing and the unit for damage (visual inspection).
3	Report any damage claims to your carrier immediately.
4	Determine if any component has become loose during shipping and, if necessary, tighten screws.

NOTICE	
	<p>If the goods delivered have been damaged during shipping, please contact the forwarding agent immediately. Retain packing material (for possible inspection or for sending back the unit).</p>

3.3 Unpacking the Power Supply

NOTICE	
	<p>If there are any visible signs of damage to the shipping containers or the product, or you later discover hidden damage, NOTIFY YOUR CARRIER IMMEDIATELY. Save the packing material.</p>

The power supply is fully assembled. It is shipped in a sturdy cardboard box. Some additional items are shipped in the box with the power supply. Note orientation of packaging material in case return/repack is necessary. When unpacking the power supply, take the following steps:

Table 3.3 Unpacking the Power Supply

Step	Action
1	Unpack the power supply as soon as it arrives. Save the packing material.
2	Verify you have all of the equipment ordered. Some components are packed inside other boxes.
3	Inspect the controls, indicators, and surface for signs of damage.
4	Remove the cover of the power supply to check if any components became loose during shipping.

3.4 Take Inventory of Small Parts

Table 3.4 Small Parts included with the Power Supply Assemblies

Part or Kit	20 kHz	30 kHz	40 kHz
Mylar®* plastic film Washer Kit	X	X	
Silicone Grease			X
Spanners (2)	X	X	X

* Mylar is a registered trademark of DuPont Teijin Films.

3.4.1 Cables

The RF cable connects the power supply to the converter. For automated systems you will also need a user I/O cable to monitor and control the power supply. Check your invoice for cable types and cable lengths.

Table 3.5 DCX F-EIP Power Supply System Cables

P/N	Description
100-240-383	Cable, RF 8 ft (2.5 m)
100-240-384	Cable, RF 15 ft (4.5 m)
100-240-385	Cable, RF 25 ft (7.5 m)
100-240-387	Cable, RF right angle 8 ft (2.5 m)
100-240-388	Cable, RF right angle 15 ft (4.5 m)
100-240-389	Cable, RF right angle 25 ft (7.5 m)
100-240-392	Cable, User I/O 25 ft (7.5 m)
100-240-393	Cable, User I/O 50 ft (15 m)
200-240-396	Cable Ethernet Cat 5e 7 ft (2.1 m)

3.5 Returning Equipment

If you are returning equipment to Branson Ultrasonic Corporation, please call your Customer Service Representative to receive approval to return the goods. Refer to [1.3 How to Contact Branson](#).

Chapter 4: Technical Specifications

4.1	Technical Specifications	38
4.2	Physical Description	41
4.3	EU Declaration of Conformity	42
4.4	UK Declaration of Conformity	43
4.5	Declaration of Conformity to the EtherNet/IP Specification	44

4.1 Technical Specifications

NOTICE	
	All specifications are subject to change without notice.

4.1.1 Environmental Specifications

The DCX F-EIP Power Supply has the following environmental specifications:

Table 4.1 Environmental Specifications

Environmental Condition	Acceptable Range
Ambient Operating Temperature	+41° F to +104° F (+5° C to +40° C)
Storage / Shipping Temperature	-13° F to +131° F (-25° C to +55° C)
Operating Altitude	Up to 6560 ft (2000 m)
Humidity	Maximum 95%, non-condensing
IP Rating	20 Protected against solid objects larger than 12.5 mm; no protection against water.
Altitude	Up to 3280ft (1000m)
Pollution degree	2 Only non-conductive pollution occurs; temporary conductivity caused by condensation may be expected.
Overvoltage category	II Equipment intended to be supplied from the building wiring.

4.1.2 Electrical Specifications

The following tables list input voltage and current requirements for the DCX F-EIP Power Supply.

Electrical Input Operating Voltages

Table 4.2 Electrical Input Operating Voltages

Power Supply Rating	Input Operating Voltage
All Models	200 V to 240 V Nominal (180 V Min.* to 253 V Max.), 50 Hz or 60 Hz, Single Phase
	24 VDC, 2.5 A

* 200 V Min. for 4 kW units.

Input Current and Fuse Specifications

Table 4.3 Input Current and Fuse Specifications

Model	Power	Current Rating
20 kHz	1250 W	7 A Max. @ 200 - 240 V / 15 A Fuse
	2500 W	14 A Max. @ 200 - 240 V / 15 A Fuse
	4000 W	25 A Max. @ 200 - 240 V / 25 A Fuse
30 kHz	1500 W	10 A Max. @ 200 - 240 V / 15 A Fuse
40 kHz	800 W	5 A Max. @ 200 - 240 V / 15 A Fuse

Continuous Duty Maximum Power

Table 4.4 Continuous Duty Maximum Power

Model	Power	Continuous Duty 30% Max. Power
20 kHz	1250 W	375 W
	2500 W	750 W
	4000 W	1200 W
30 kHz	1500 W	450 W
40 kHz	800 W	240 W

NOTICE	
	<p>High duty cycles require additional cooling for the converter. For information on converter cooling refer to 5.7 Converter Cooling in Chapter 5: Installation and Setup.</p>

NOTICE	
	<p>System average power must be limited to the specified continuous maximum. Duty cycle for each power and frequency is 1 second on and 2.4 seconds off.</p>

Cycle Rate – up to 200 cpm. Cycle rate including off time is application and stack dependent.

4.2 Physical Description

This section describes the physical dimensions of the DCX F-EIP Power Supply.

NOTICE	
	Dimensions are nominal.

Table 4.5 Dimensions and Weights of DCX F-EIP Power Supply

Size	Width	Height	Depth	Weight
Small	4.2" 106 mm	5.07" 128 mm	22" 560 mm	8 lb 3.6 kg
Medium	5.6" 142 mm			12 lb 5.4 kg
Large	8.4" 213 mm			15 lb 6.8 kg

For detailed dimensional information refer to [Chapter 5: Installation and Setup](#).

4.3 EU Declaration of Conformity

Figure 4.1 EU Declaration of Conformity

EU DECLARATION OF CONFORMITY

CE

We, the manufacturer

BRANSON ULTRASONICS CORPORATION
120 Park Ridge Rd.
Brookfield, CT 06804
USA

represented in the community by

BRANSON ULTRASONICS, a.s.
Piestanska 1202
91501 Nove Mesto nad Vahom
Slovak Republic

expressly declare under our sole responsibility that the following electrical equipment product:

Ultrasonic Assembly System consisting of an Ultrasonic Power Supply, model:

0.80 DCX(S, A, f-EIP, f-DP or f-pfn) 40 RACKMT 1.50 DCX(S, A, f-EIP, f-DP or f-pfn) 30 RACKMT 1.25 DCX(S, A, f-EIP, f-DP or f-pfn) 20 RACKMT 2.50 DCX(S, A, f-EIP, f-DP or f-pfn) 20 RACKMT 4.00 DCX(S, A, f-EIP, f-DP or f-pfn) 20 RACKMT DCX RM 222 STD DCX RM 240 STD DCX RM 222 B DCX RM 240 B DCX RM 480 STD DCX RM 315 STD DCX RM 211 STD DCX RM 480 B DCX RM 315 B DCX RM 211 B P/S 2.20 DCX STD 20 SIG	0.40DCX(s, v, a, f-dp, f-eip or f-pfn)40(VRT, V, H or HOR) 0.80DCX(s, v, a, f-dp, f-eip or f-pfn)40(VRT, V, H or HOR) 0.75DCX(s, v, a, f-dp, f-eip or f-pfn)30(VRT, V, H or HOR) 1.50DCX(s, v, a, f-dp, f-eip or f-pfn)30(VRT, V, H or HOR) 1.25DCX(s, v, a, f-dp, f-eip or f-pfn)20(VRT, V, H or HOR) 2.50DCX(S+, s, v, a, f-dp, f-eip or f-pfn)20(VRT, V, H or HOR) 4.00DCX(S+, s, v, a, f-dp, f-eip or f-pfn)20(VRT, V, H or HOR) 4.00DCXs20HD -V P/S 0.8 DCX S HD 40 VRT 1.50 DCX-S HD 30 (HOR or VRT) 1.50 DCX-S HD 30 VRT 4.00DCXs20HD -H P/S 0.8 DCX S HD 40 HOR P/S 4.0KW 20KHZ DCX S LIM RES 1.6DCX(a, f-dp, f-eip or f-pfn)40(B2H or B2V)
---	---

used with converter model: CR-20S, CR-20C, CH-20C, CS-20S, CS-20C, CR-30, CR-30C, CH-30, CH-30C, CS-30S, CS-30C, CR-40C, 4TH, 4TP or 932, and associated cables.

in the state in which it was placed on the market, fulfills all the relevant provisions and their amendments of:

Low Voltage Directive **2014/35/EU**
EMC Directive **2014/30/EU**
RoHS Directive **2011/65/EU**

The object of this declaration is in conformity with relevant Union harmonization legislation. The electrical equipment product, to which this declaration relates, is in conformity with the following standards:

EN 61010-1:2010+A1:2019
EN 55011:2016/A11:2020
EN 61000-6-2:2005/AC:2005

Brookfield, CT, USA

Luis Benavides

Luis Benavides (Feb 17, 2026 14:02:32 CST)

Director of Engineering, Systems / Product Safety Officer

4.4 UK Declaration of Conformity

Figure 4.2 UK Declaration of Conformity



UK DECLARATION OF CONFORMITY

We, the manufacturer

BRANSON ULTRASONICS CORPORATION

120 Park Ridge Rd.
Brookfield, CT 06804
USA

expressly declare under our sole responsibility that the following electrical equipment product:

Ultrasonic Assembly System consisting of an Ultrasonic Power Supply, model:

0.80 DCX(S, A, f-EIP, f-DP or f-pfn) 40 RACKMT	0.40DCX(s, v, a, f-dp, f-eip or f-pfn)40(VRT, V, H or HOR)
1.50 DCX(S, A, f-EIP, f-DP or f-pfn) 30 RACKMT	0.80DCX(s, v, a, f-dp, f-eip or f-pfn)40(VRT, V, H or HOR)
1.25 DCX(S, A, f-EIP, f-DP or f-pfn) 20 RACKMT	0.75DCX(s, v, a, f-dp, f-eip or f-pfn)30(VRT, V, H or HOR)
2.50 DCX(S, A, f-EIP, f-DP or f-pfn) 20 RACKMT	1.50DCX(s, v, a, f-dp, f-eip or f-pfn)30(VRT, V, H or HOR)
4.00 DCX(S, A, f-EIP, f-DP or f-pfn) 20 RACKMT	1.25DCX(s, v, a, f-dp, f-eip or f-pfn)20(VRT, V, H or HOR)
DCX RM 222 STD	2.50DCX(S+, s, v, a, f-dp, f-eip or f-pfn)20(VRT, V, H or HOR)
DCX RM 240 STD	4.00DCX(S+, s, v, a, f-dp, f-eip or f-pfn)20(VRT, V, H or HOR)
DCX RM 222 B	4.00DCXs20HD -V
DCX RM 240 B	P/S 0.8 DCX S HD 40 VRT
DCX RM 480 STD	1.50 DCX-S HD 30 (HOR or VRT)
DCX RM 315 STD	1.50 DCX-S HD 30 VRT
DCX RM 211 STD	4.00DCXs20HD -H
DCX RM 480 B	P/S 0.8 DCX S HD 40 HOR
DCX RM 315 B	P/S 4.0KW 20KHZ DCX S LIM RES
DCX RM 211 B	1.6DCX(a, f-dp, f-eip or f-pfn)40(B2H or B2V)
P/S 2.20 DCX STD 20 SIG	

used with converter model: CR-20S, CR-20C, CH-20C, CS-20S, CS-20C, CR-30, CR-30C, CH-30, CH-30C, CS-30S, CS-30C, CR-40C, 4TH, 4TP or 932, and associated cables.

in the state in which it was placed on the market, fulfills all the relevant provisions and their amendments of:

Electrical Equipment (Safety) Regulations **2016**
Electromagnetic Compatibility Regulations **2016**
Restriction of the Use of Certain Hazardous Substances in Electrical and Electronic Equipment Regulations **2012**.

The electrical equipment product, to which this declaration relates, is in conformity with the following designated standards:

EN 61010-1:2010+A1:2019
EN 55011:2016/A11:2020
EN 61000-6-2:2005/AC:2005

Brookfield, CT, USA

Luis Benavides

Luis Benavides (Feb 17, 2026 14:02:48 CST)

Director of Engineering, Systems / Product Safety Officer

4.5 Declaration of Conformity to the EtherNet/IP Specification

Figure 4.3 Declaration of Conformity to the EtherNet/IP Specification Page 01



DECLARATION OF CONFORMITY

Declaration of Conformity (DOC) Reference Information		
File Number:	11245.03	Part 1 of 1
Year Last Issued:	2016	
Length of Validity:	Continues in effect so long as the named entity (i) remains an ODVA Licensed Vendor for the ODVA technology(ies) defined by the above specification(s); (ii) continues to fulfill its user responsibilities as defined in its Terms of Usage Agreement with ODVA; and (iii) the CIP Identity for the Product(s) remains identical to those enumerated in this Declaration of Conformity.	

ODVA Licensed Vendor to Whom this DOC Has Been Issued	
Entity Name:	Branson Ultrasonics
Vendor ID:	1283

Overview of Compliant Product(s) Covered by This DOC	
<small>(The list of product(s) covered by this DOC begins on page 2.)</small>	
Network(s) Supported:	EtherNet/IP™
CIP Device Profile Supported:	Generic Device (keyable)
Classification of Declaration:	single product

Trademark(s) Approved for Use in the Labeling and Promotion of the Products Named Herein	
<small>(Color variations of logo marks allowed pursuant to ODVA Brand Standards+Identity Guidelines. No abbreviation of word marks allowed.)</small>	
Logo Marks	Word Marks
ODVA Certification Marks	
	ODVA CONFORMANT™
ODVA Technology Marks	
	EtherNet/IP™

This Declaration of Conformity, and approval of the use of ODVA's trademarks as shown above, has been granted by ODVA, Inc. based on its determination that the Product(s) identified herein fulfill(s) ODVA's standards for compliance with ODVA's specifications listed below at the ODVA composite Conformance Test (CT) level shown in parentheses:

The EtherNet/IP™ Specification (CT 12)

This Declaration of Conformity is issued on **March 30, 2016** on behalf of ODVA by:

Katherine Voss, Executive Director

The list of product(s) covered by this DOC begins on page 2.

Figure 4.4 Declaration of Conformity to the EtherNet/IP Specification Page 02

CIP Identity for Product(s) Covered Under this Declaration of Conformity (per CIP Identity Object)			
No.	Vendor Product Code (attribute 3)	Vendor Product Revision (attribute 4)	Vendor Product Name (attribute 7)
1	2	2.001	DCX_FE

Declaration of Conformity
File No.: 11245.03

Part 1 of 1 - page 2 of 2

© 2015 ODVA, Inc. The content of this Declaration of Conformity is public information and this Declaration may be reproduced in whole, but not in parts, without modification.





Chapter 5: Installation and Setup

5.1	About Installation	48
5.2	Installation Requirements	49
5.3	Installation Steps	55
5.4	User I/O	58
5.5	Power Supply Setup	74
5.6	Assembling the Acoustic Stack	75
5.7	Converter Cooling	80
5.8	Testing the Installation	82
5.9	Still Need Help?	83

5.1 About Installation

This chapter is intended to help the installer with the basic installation and setup of your new DCX F-EIP Power Supply.

CAUTION	Heavy Object
	The power supply, and related components are heavy. Handling, unpacking, and installation may require the assistance of a colleague or the use of lifting platforms or hoists.

International safety-related labels are found on the power supply. Those that are of importance during installation of the system are identified in [Figure 1.1 Safety-related Labels found on the DCX F-EIP Power Supply](#).

5.2 Installation Requirements

This section covers the location requirements, mounting options, power supply dimensions, environmental requirements, and electrical requirements, to help you plan and execute your installation successfully.

5.2.1 EtherNet/IP Wiring Considerations

It is recommended to use as a minimum Cat5 Ethernet cable on new installations with a maximum cable length of 100 m (328 ft). If existing cabling is of lower category, maximum data rate may be limited.

5.2.2 Installing the DCX F-EIP Power Supply in a Customer Rack

The power supply units can be installed in any rack complying with the 19" industrial standard.

For successful installation in a rack, the respective demands on the electric and cooling system have to be met.

- If multiple drawers are to be installed in a rack we recommend to provide three phase power to the rack in order to provide each drawer with a dedicated supply and one phase to each drawer
- Particular care has to be taken that the heat generated during operation is dissipated. The heat generated depends on the power output by the module and the ambient conditions
- The heat sink of the module is mounted on the right. Make sure that the cooling device is mounted in a way allowing the cooling air to pass freely on this side
- For each group of four power supply modules installed one cooling drawer is required. The cooling drawers must be installed directly under the power supplies in order to ensure sufficient cooling
- In case a filter element is used to clean the intake air, regular inspection and cleaning of the filter depending on the ambient conditions is required to maintain the airflow volume
- To prevent thermal overload, the system is protected by thermostats which are reset automatically after cooling down

NOTICE	
	<p>Three 105 CFM fans must be placed directly underneath each unit for cooling.</p>

5.2.3 Location

The power supply should be accessible for parameter changes and settings. The power supply should be located in an area away from radiators or heating vents.

The DCX F-EIP Power Supply must not be positioned so that is difficult to plug in or unplug the main power plug.

5.2.4 Dimensions

Refer to the illustrations on the pages that follow for dimensional drawings. All dimensions are approximate and may vary slightly:

[Figure 5.1 DCX F-EIP Power Supply Dimensional Drawing \(Small\)](#)

[Figure 5.2 DCX F-EIP Power Supply Dimensional Drawing \(Medium\)](#)

Figure 5.3 DCX F-EIP Power Supply Dimensional Drawing (Large)

Figure 5.1 DCX F-EIP Power Supply Dimensional Drawing (Small)

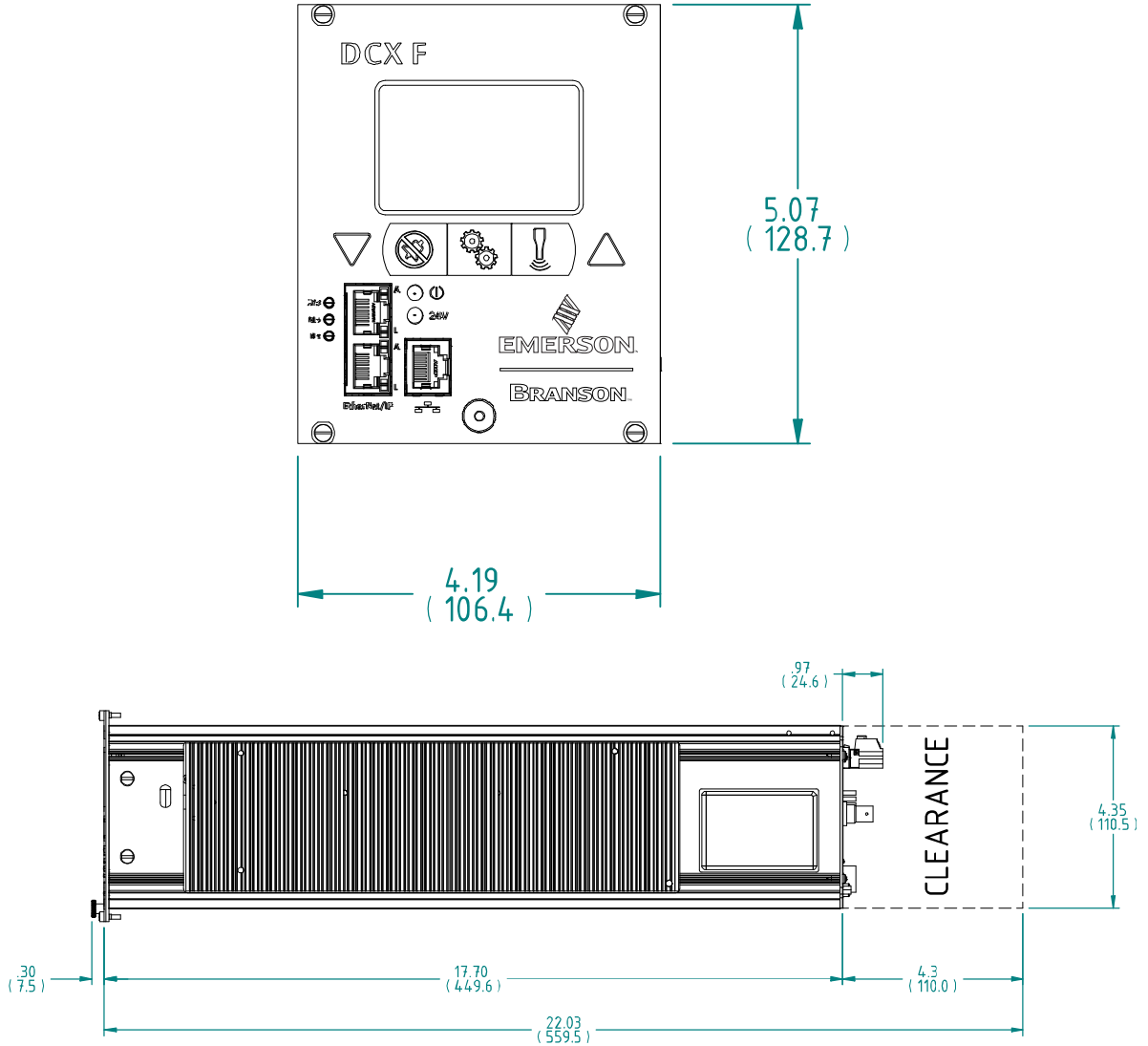

Figure 5.2 DCX F-EIP Power Supply Dimensional Drawing (Medium)

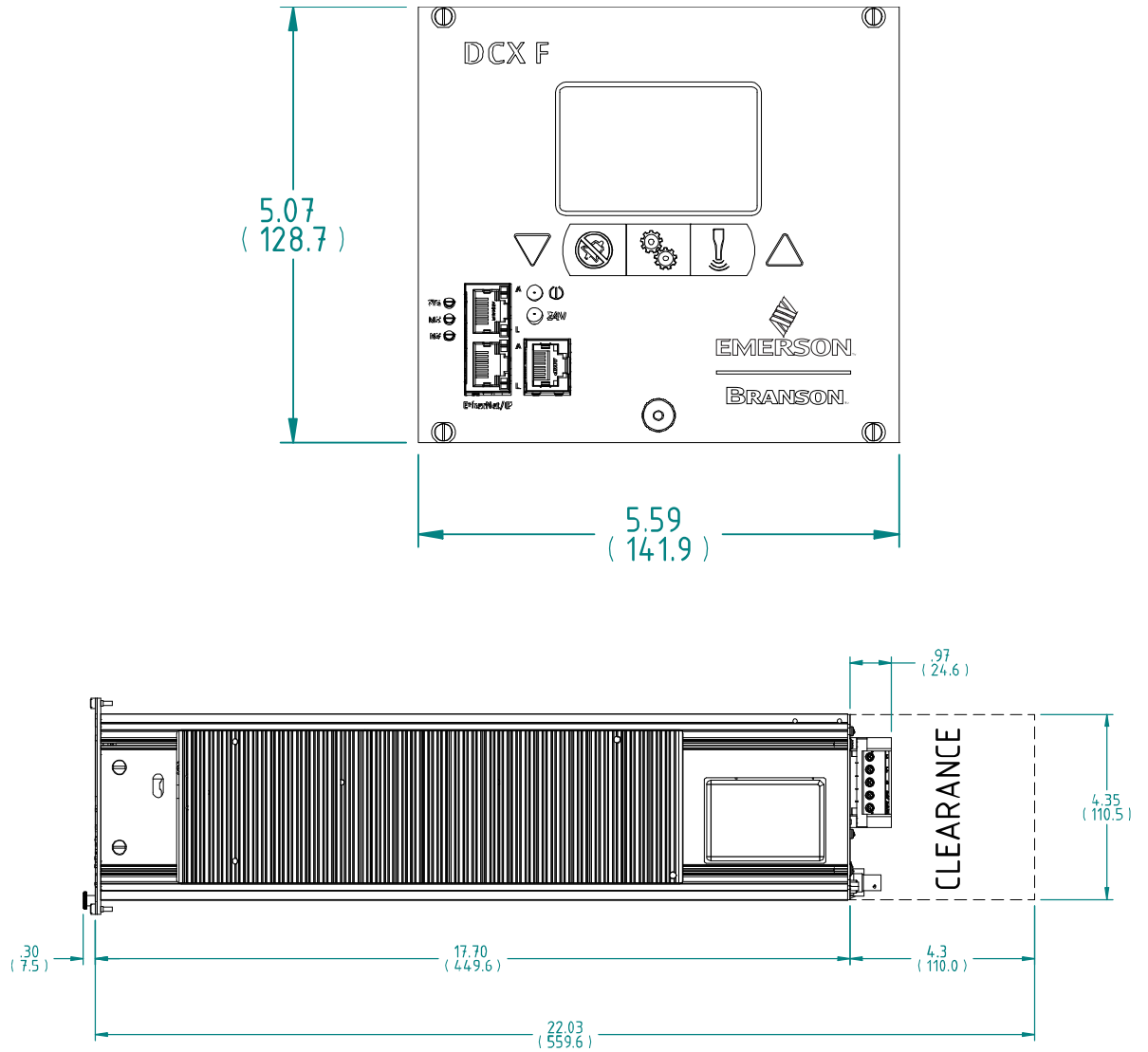
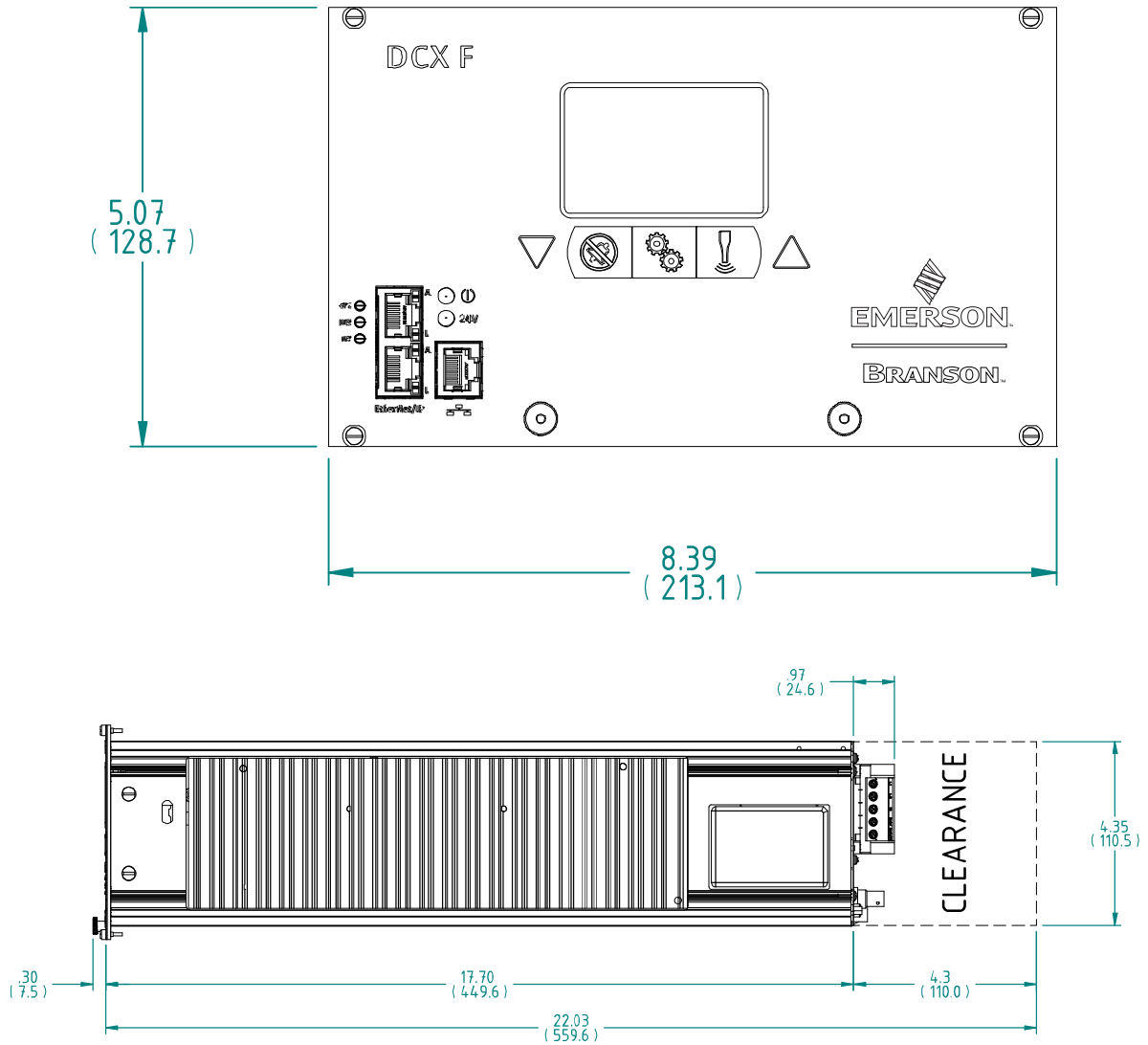

Figure 5.3 DCX F-EIP Power Supply Dimensional Drawing (Large)



5.2.5 Environmental Requirements

Verify the DCX F-EIP Power Supply is operated in an environment that meets the temperature and humidity requirements indicated in [Table 5.1 Environmental Requirements](#).

Table 5.1 Environmental Requirements

Environmental Condition	Acceptable Range
Ambient Operating Temperature	+41° F to +104° F (+5° C to +40° C)
Storage / Shipping Temperature	-13° F to +131° F (-25° C to +55° C)
Operating Altitude	Up to 6560 ft (2000 m)
Humidity	Maximum 95%, non-condensing
IP Rating	20 Protected against solid objects larger than 12.5 mm; no protection against water.
Altitude	Up to 3280ft (1000m)
Pollution degree	2 Only non-conductive pollution occurs; temporary conductivity caused by condensation may be expected.
Overvoltage category	II Equipment intended to be supplied from the building wiring.

5.2.6 Electrical Input Power Ratings

Connect the power supply to a single-phase, grounded, 3-wire, 50 Hz or 60 Hz 200 V to 240 V power source. [Table 5.2 Input Current and Circuit Breaker Specifications](#) lists the current and breaker ratings for the various models.

Table 5.2 Input Current and Circuit Breaker Specifications

Model	Power	Current Rating
20 kHz	1250 W	7 A Max. @ 200 - 240 V / 15 A Breaker
	2500 W	14 A Max. @ 200 - 240 V / 15 A Breaker
	4000 W	25 A Max. @ 200 - 240 V / 25 A Breaker
30 kHz	1500 W	10 A Max. @ 200 - 240 V / 15 A Breaker
40 kHz	800 W	5 A Max. @ 200 - 240 V / 10 A Breaker

5.2.7 Pneumatic Requirements

Your welding system may require a cooling air stream for the converters. In continuous operations, or applications with longer duty cycles, it may be necessary to cool the horn as well as the converter.

Typically 80 cubic feet (2.26 m³) per hour of clean, dry, compressed air are required to cool most welding operations.

To verify the 80 cubic feet (2.26 m³) per hour cooling air stream required for your welding system, refer to [5.7 Converter Cooling](#).

5.3 Installation Steps

WARNING	High Voltage Hazard
	<p>To prevent the possibility of an electrical shock:</p> <ul style="list-style-type: none"> • Ensure the power source is disconnected before beginning to work on line connections • Always plug the power supply into a grounded power source • To prevent the possibility of an electrical shock, ground the power supply by securing an 8 gauge grounded conductor to the ground screw located next to the air outlet • Ensure power supply installation is performed by qualified personnel and in accordance with local standards and regulations

All persons who are involved with installation, commissioning, operation and maintenance must have the required qualification, strictly follow this operating manual.

Basic installation notes:

- To avoid problems associated with EMI, you should route high power lines (AC and Ultrasonic RF) away from low power lines (controls signals)
- You should consider future troubleshooting and repair when installing all wiring. All wiring should be either color coded or tagged with industrial wire tags
- The minimum cable bend radius is 5 times the cable outer diameter for RF cables
- The minimum cable bend radius is 10 times the cable outer diameter for user I/O & Ethernet cables
- Ground wires should not be shared with other equipment
- All inductive coils must be suppressed with appropriate devices, such as diodes or RC networks

5.3.1 Mount the Power Supply

The cable lengths are limited based on the operating frequency of the welding system. Performance and results can suffer if the RF cable is crushed, pinched, damaged or modified. Contact your Branson Representative if you have special cable requirements.

Do not place the power supply on the floor or in other locations that will allow dust, dirt or contaminants to be drawn into the power supply.

NOTICE	
	<p>Do not block exhaust and intake air circulation, which is needed to maintain a safe operating temperature.</p>

5.3.2 Mounting Considerations

In addition to the considerations mentioned above, the LCD's viewing angle should be taken into account when selecting a location for your DCX F-EIP Power Supply. The LCD is designed to be viewed from the top. Please refer to [Figure 5.4 LCD Viewing Angle](#) below when selecting a location for your DCX F-EIP Power Supply.

Figure 5.4 LCD Viewing Angle



NOTICE	
	<p>Optimal viewing angle is 25° above the normal to the display (indicated by 0°).</p>

5.3.3 Electrical Connections

Figure 5.5 DCX F-EIP Power Supply Connections

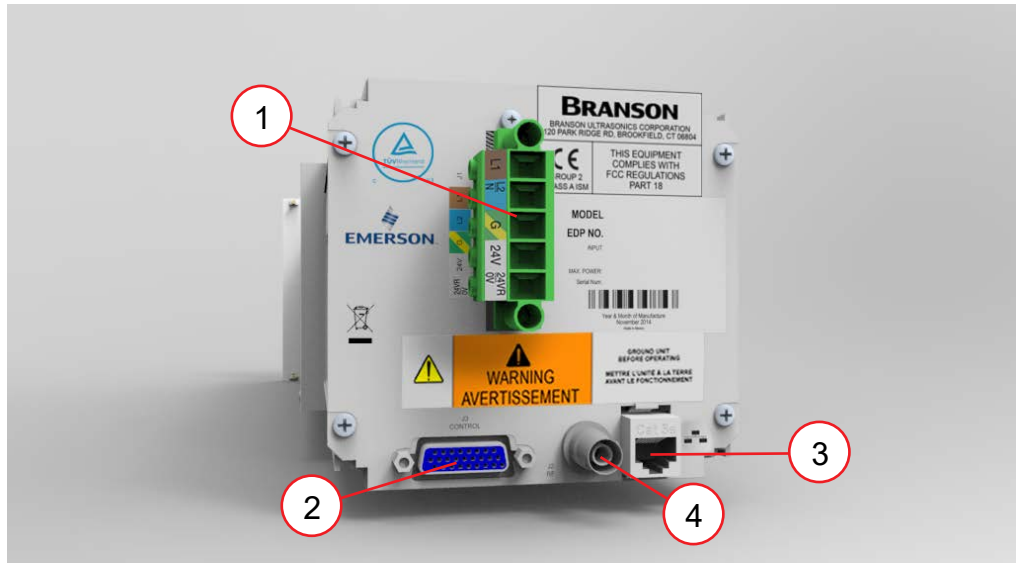



Table 5.3 DCX F-EIP Power Supply Connections

Item	Name
1	Line Input Connector
2	User I/O Connector
3	Ethernet Port
4	RF Connector

5.4 User I/O

5.4.1 User I/O Connections

NOTICE	
	User I/O interface is only available in manual mode.

The user I/O is a standard interface for automation, provided on the power supply. It provides the ability to make your own interface for your automation, actuator interface, special control, or reporting needs. The interface cable has a 26-pin HD male D-Sub connector on one end, and wires on the other end. Pins are wired to ICEA standard color code (see [Figure 5.6 User I/O Cable Identification and Wire Color Diagram](#) and [Table 5.5 User I/O Cable Pin Assignments](#)).

NOTICE	
	Ensure all unused wires are properly isolated. Failure to do so may result in a power supply malfunction.

Digital I/O functions can be configured to either active-high or active-low using the DCX F-EIP Power Supply Web Page Interface. [Table 5.7 Digital Input Functions](#) to [Table 5.10 Analog Output Functions](#) list the input and output functions available on the DCX F-EIP Power Supply. See [Table 5.6 Default Branson User I/O Connector Pin Assignments](#) for the default user I/O pin assignments.

[Figure 5.7 Typical Digital I/O Wiring Examples](#) and [Figure 5.8 Typical Analog I/O Wiring Examples](#) show typical wiring examples.

Figure 5.6 User I/O Cable Identification and Wire Color Diagram

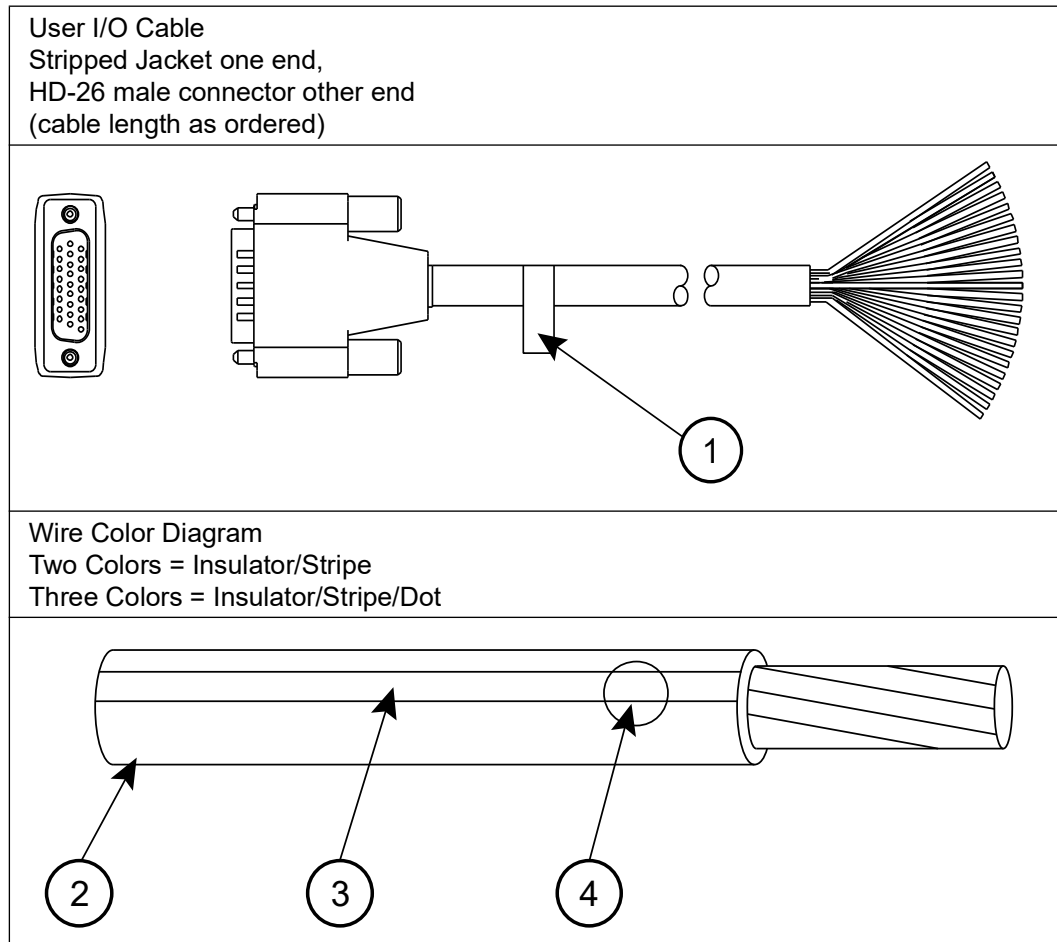

Table 5.4 User I/O Cable Identification and Wire Color Diagram

Item	Description
1	Part number
2	Insulation
3	Stripe
4	Dot

5.4.2 User I/O Cable Pin Assignments

Table 5.5 User I/O Cable Pin Assignments

Pin	Input/Output	Available Function	Signal Type	Signal Range	Color
1	Digital in 1	See Table 5.7 Digital Input Functions	Digital Input	0V to 24V \pm 10%, 12mA	Blk
2	Digital in 2				Wht
3	Digital in 3				Red
4	Digital in 4				Grn
5	+24V	N/A	24V Source	24V \pm 10%, 250mA Max	Orn
6					Blu
7	Digital out 1	See Table 5.8 Digital Output Functions	Digital Output	0V to 24V, \pm 10%, 25mA Max	Wht/Blk
8	Digital out 2				Red/Blk
9	Digital out 3				Grn/Blk
10	Digital out 4				Orn/Blk
11	Digital in 5	See Table 5.7 Digital Input Functions	Digital Input	0V to 24V \pm 10%, 12mA	Blu/Blk
12	Digital in 6				Blk/Wht
13	Digital in 7				Red/Wht
14	Ground	N/A	24V Ground	0V	Grn/Wht
15					Blu/Wht
16	Digital in 8	See Table 5.7 Digital Input Functions	Digital Input	0V to 24V \pm 10%, 12mA	Blk/Red
17	Analog in 1	See Table 5.9 Analog Input Functions	Analog Input	0V to +10V, 2mA	Wht/Red
18	Analog in 2				Orn/Red
19	Digital out 5	See Table 5.8 Digital Output Functions	Digital Output	0V to 24V \pm 10%, 12mA Max	Blu/Red
20	Digital out 6				Red/Grn
21	Digital out 7				Orn/Grn
22	Digital out 8				Blk/Wht/Red
23	Digital in 9	See Table 5.7 Digital Input Functions	Digital Input	0V to 24V \pm 10%, 12mA	Wht/Blk/Red

Table 5.5 User I/O Cable Pin Assignments

Pin	Input/Output	Available Function	Signal Type	Signal Range	Color
24	Analog out 1	See Table 5.10 Analog Output Functions	Analog Output	0V to 10V \pm 5%, 1mA Max	Red/Blk/Wht
25	Analog out 2				Grn/Blk/Wht
26	Analog Ground	N/A	Analog Ground	0V	Orn/Blk/Wht

5.4.3 Default Branson User I/O Connector Pin Assignments

Table 5.6 Default Branson User I/O Connector Pin Assignments

Pin	Input/Output	Signal Type	Signal Description
1	STD-External Start	Digital Input	Apply +24VDC to run cycle NOTICE Power supply must be in ready mode before External Start NOTICE Signal must be held for 10ms minimum
2	STD-External Seek		Apply +24VDC to perform a seek
3	STD-External Reset		Apply +24VDC to reset alarm
4	STD-Memory Clear		Apply +24VDC to clear memory
5	+24VDC Source	I/O Signal Source	+24V, 250mA Max
6			
7	STD-Ready	Digital Output	+24V indicates the system is ready
8	STD-Sonics Active		+24V indicates ultrasonics are active
9	STD-General Alarm		+24V indicates an alarm occurred
10	STD-Seek/Scan Out		+24V indicates either Seek or a Scan is in progress
11	STD-Recall Preset 1	Digital Input	Bit 0 for preset recall binary code
12	STD-Recall Preset 2		Bit 1 for preset recall binary code
13	ACT-Ground Detect		Apply +24 VDC to activate ground detect
14	+24VDC Return and I/O Return	I/O Signal Return	Return for all pins except pins 17, 18, 24, and 25
15			
16	ACT-Cycle Abort	Digital Input	Apply +24 VDC to abort cycle
17	Amplitude In	Analog Input	+1V to +10V (10% to 100%)*
18	Frequency Offset		+1V to +9V (5V is zero offset)
19	STD-Confirm Preset Change	Digital Output	+24V indicates a load new preset request has occurred and the preset was successfully recalled
20	STD-Overload Alarm		+24V indicates an overload alarm occurred
21	STD-Plus Peak Power Limit Alarm		+24 V indicates a +peak power limit alarm occurred
22	STD-Minus Peak Power Limit Alarm		+24V indicates a -peak power limit alarm occurred

Table 5.6 Default Branson User I/O Connector Pin Assignments

Pin	Input/Output	Signal Type	Signal Description
23	STD-Display Lock	Digital Input	Apply +24 VDC to lock the display
24	Power Out	Analog Output	0V to +10V (0% to 100%)
25	Amplitude Out		0V to +10V (0% to 100%)
26	Analog Signal Return	Analog Signal Return	Return for pins 17, 18, 24, and 25

*If the input signals are not within their valid range, or if left unconnected, the power supply will use 50% amplitude and zero frequency offset, respectively.

5.4.4 Digital Input Functions

Table 5.7 Digital Input Functions

Function	Description
ACT-Actuator Present	Must be active at power up to activate TRS, ULS, Interlock, Part in Place.
ACT-Cycle Abort	Will immediately terminate the current weld cycle and not accept another External Start until removed. Reset required is user settable.
ACT-Ground Detect	Will start scrub time. When scrub time expires, ultrasonics will be turned off.
ACT-Interlock In Place	Prevents a cycle from starting until the signal becomes active.
ACT-Part In Place	When enabled, signal must be active before weld cycle is started.
ACT-Trigger Switch (TRS)	Indicates the power supply to start ultrasonics.
ACT-Upperlimit Switch (ULS)	Tells the power supply that the actuator is at home position.
RF-Feedback A, B, C, D	Indicates which relay the RF switch has changed to. Bit 0 to bit 3 are binary coded values indicating the selected RF switch. It can also be uncoded. This function is user settable.
RF-Status Feedback	Indicates the RF switch has changed to the proper relay. NOTICE Single value. Not coded/uncoded like RF-Feedback A, B, C, D.
STD-Cable Detect	When enabled 24 volts must be present on pin at all times. If 24 volts is removed, suggesting that the cable has been removed, ultrasonics will not be allowed to run and will stop if already running.
STD-Display Lock	Locks the front panel display controls. Registers are read only when signal is active.
STD-External Amp Step Trigger	When set to +24 V sets amplitude to Amplitude 2. If set again to 0 V during a weld cycle will set amplitude back to Amplitude 1. Used only if amplitude stepping is turned on and set to external input.
STD-External Horn Scan	Starts horn scan. Signal must be maintained during the scan.
STD-External Reset	Resets alarm conditions.
STD-External Seek	Activates ultrasonic energy at 10% amplitude for the purpose of finding the ultrasonic stack resonant frequency.

Table 5.7 Digital Input Functions

Function	Description
STD-External Sonics Delay	Delays the start of ultrasonics even if a trigger occurs. This can be used to enable an external operation to be complete before continuing the cycle (e. g. test device or part marking operation). If the delay is maintained for 1 minute, the cycle is aborted and all inputs must be cycled again.
STD-External Start	<p>Activates ultrasonic energy at the currently set amplitude.</p> <p>NOTICE DCX F-EIP Power Supply must be in ready mode before External Start.</p> <p>WARNING When using 0 V to activate ultrasonics (External Start signal), it is recommended to assign one input as Cable Detect to prevent sonics from activating if 24 V is lost by accident.</p>
STD-External Test	Performs a test cycle. Signal must be maintained.
STD-Load New Preset	Loads a weld preset as defined by Recall Preset Bits 1-32.
STD-Memory Clear	Centers the power supply start frequency.
STD-Recall Preset 1, 2, 4, 8, 16, 32	Bit 0 to bit 5 for preset recall binary code. This code will be used to recall a preset when Load Preset input is activated.
STD-Sonics Disable	Prevents ultrasonics from coming on. If active throughout a weld cycle, the cycle will be performed but without ultrasonics. Should the weld mode be time indeterminate (energy, power, etc) then the weld time will extend to the cutoff time.
STD-Start Cycle	Starts a cycle.

5.4.5 Digital Output Functions

Table 5.8 Digital Output Functions

Function	Description
ACT-Actuator Home	Indicates that a ULS input has been received.
ACT-Afterburst Delay	Indicates if the weld cycle is in the Afterburst Delay state.
ACT-Afterburst Time	Indicates if the weld cycle is in the Afterburst state.
ACT-End of Hold Time	Indicates the system has reached the end of Hold since the cycle started.
ACT-Holdtime	Indicates if the weld cycle is in the Hold Time state.
RF-Select A-D	Output to select stacks 1 to 4 or a binary coded value (bit 0-3) to select RF relay.
STD-Amp1 Amp2	If output is 0 V, indicates the amplitude setting is Amplitude 1. If output is 24 V, indicates the amplitude setting is Amplitude 2.
STD-Confirm Preset Change	Output will go active when a preset has been recalled.
STD-Custom Alarm	Indicates a Custom Alarm has occurred. This function is user defined.
STD-Cycle Okay	Output will go inactive with cycle start input, and will go high at the end of the cycle if no alarms occurred.
STD-Cycle Start Out	Indicates start signal is active. It will stay active through weld time and hold time.
STD-General Alarm	Indicates an alarm occurred. This function is user configurable.
STD-Minus Energy Limit Alarm	Indicates the weld did not reach the minimum energy set.
STD-Minus Time Limit Alarm	Indicates the weld time has not reached the minimum time set.
STD-Minus Peakpower Limit Alarm	Indicates the weld has not reached the minimum peak power set.
STD-Overload Alarm	Indicates an overload alarm has occurred.
STD-Plus Energy Limit Alarm	Indicates the weld has exceeded the maximum energy set.

Table 5.8 Digital Output Functions

Function	Description
STD-Plus Time Limit Alarm	Indicates the weld time did exceed the maximum time set.
STD-Plus Peakpower Limit Alarm	Indicates the weld has exceeded the maximum peak power set.
STD-Ready	If active, indicates the system is ready to start a weld cycle, enter test mode, or start a horn scan. If inactive, it indicates the system is already cycling, in test mode, performing a horn scan, or has a reset-required alarm.
STD-Seek/Scan Out	Indicates either a seek or a horn scan is in progress.
STD-Sonics Active	Indicates sonics are active.
STD-Start Signal Release	If output is active, it indicates the start signal can be removed. If output is inactive, it indicates start signal is either inactive or that it cannot yet be removed.
STD-Status	To be used to drive an external beeper. Single 0.5 second beeps will occur when trigger is received. Three Beeps indicate an alarm occurred (e.g. overload alarm). Beeps 0.5 seconds on, 0.5 seconds off long are in between each beep.
STD-Weldcycle Complete	Indicates if a weld cycle is no longer in process.

5.4.6 Analog Input Functions

Table 5.9 Analog Input Functions

Function	Description		Valid Range
Amplitude In	Controls the amplitude of ultrasonic energy that will be delivered by the power supply.		1 V to 10 V* (10% to 100%)
Custom Input 1, 2	Define an analog voltage that can be used to create a cutoff. Voltage must be exceeded to produce the cutoff.		0 V to 10 V
Frequency Offset	Controls the frequency offset to the power supply operating frequency. Actual offset depends on the power supply operating frequency:		1 V to 9 V* (5 V is zero offset)
	Frequency	Offset Range	
	20 kHz	+/- 400 Hz	
	30 kHz	+/- 600 Hz	
	40 kHz	+/- 800 Hz	

* If the input signals are not within their valid range, or if left unconnected, the power supply will use 50% amplitude and zero frequency offset, respectively.

5.4.7 Analog Output Functions

Table 5.10 Analog Output Functions

Function	Description			Valid Range
Amplitude Out	Provides a 0 V to 10 V output signal proportional to amplitude (0% to 100%).			0 V to 10 V (0% to 100%)
Power Out	Provides a 0 V to 10 V output signal proportional to ultrasonic power output (0% to 100%).			0 V to 10 V (0% to 100%)
Frequency Out	Provides a 0 V to 10 V output signal that indicates memory plus offset. Actual frequency depends on the power supply operating frequency:			0 V to 10 V (5 V is zero offset)
	Frequency	Lower Limit (0 V)	Upper Limit (10 V)	
	20 kHz	19,450 Hz	20,450 Hz	
	30 kHz	29,250 Hz	30,750 Hz	
	40 kHz	38,900 Hz	40,900 Hz	

5.4.8 Typical Digital I/O Wiring Examples

Figure 5.7 Typical Digital I/O Wiring Examples

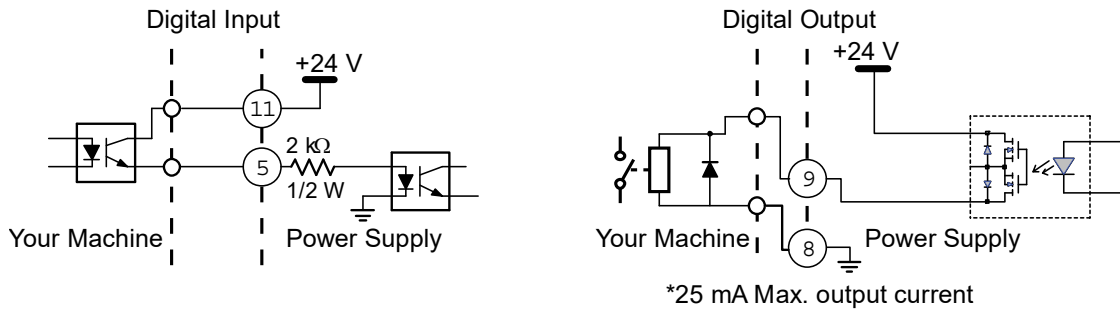

5.4.9 Typical Analog I/O Wiring Examples

Figure 5.8 Typical Analog I/O Wiring Examples

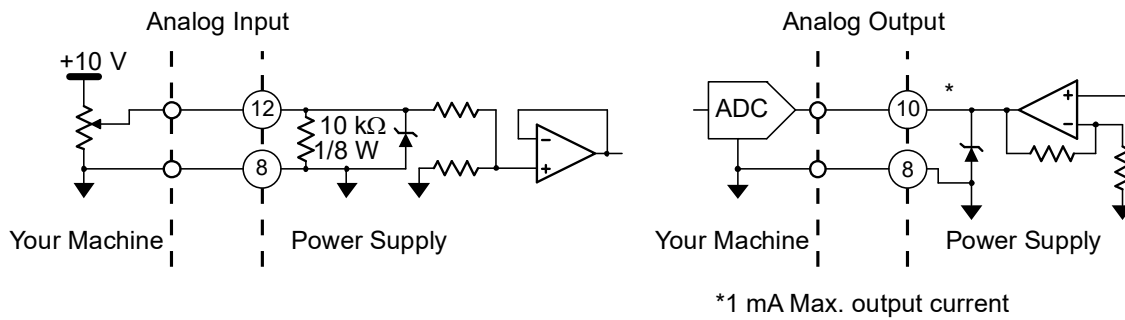

5.4.10 Output Power (RF Cable) Connection

Ultrasonic energy is delivered to the SHV connector on the power supply, which is then transmitted to the converter via the RF cable. The RF connector position depends on the power supply configuration. For Horizontal models it is located on the rear panel of the power supply. For Vertical models it is located on the bottom panel of the power supply.

To reduce electromagnetic interference (EMI), RF cables are equipped with a ferrite core (plastic case) on one end. This end is meant to be connected to the power supply.

WARNING	High Voltage Hazard
	Operating the System with the RF Cable disconnected or damaged can present an electrical shock hazard.

WARNING	High Voltage Hazard
	To avoid the possibility of electrical shock, converters need to be properly grounded.

NOTICE	
	To avoid the possibility of EMI, ensure the RF connection to the power supply is made with the cable end that has the ferrite core box attached (see Figure 5.9 RF Cable Connection).

Figure 5.9 RF Cable Connection

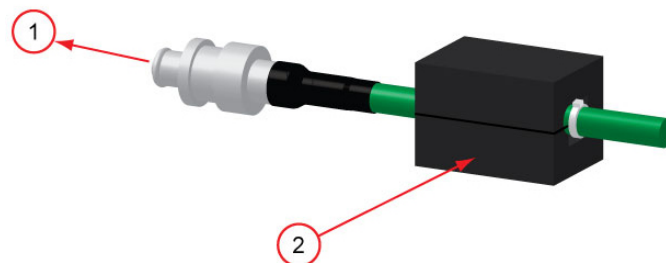





Table 5.11 RF Cable Connection

Item	Description
1	To Power Supply
2	Ferrite Core Box

5.4.11 Input Power Connection

WARNING	High Voltage Hazard
	<p>Ensure all electrical power is off when wiring input power to your DCX F-EIP Power Supply connector block.</p> <p>To prevent the possibility of an electrical shock, ground the power supply by securing an 8 gauge grounded conductor to the ground screw located next to the air outlet.</p>

WARNING	High Voltage Hazard
	<p>If miss-wired, the power supply can present an electrical shock hazard.</p>

NOTICE	
	<p>The power supply can be permanently damaged if it is connected to the incorrect line voltage, or if the connection is mis-wired.</p>

Use the following procedure to connect the power supply to a 24 VDC 2.5A external power supply and to a single-phase, grounded 3-wire, 50 Hz or 60 Hz 200 V to 230 V power source. The 24 VDC power supply must be safety certified and agency approved.

Table 5.12 Input Power Connection

Step	Action
1	Detach the connector block on the back of the power supply.
2	Use two properly sized wires (according to local standards) to connect a 24 VDC 2.5A power supply as shown on Figure 5.5 DCX F-EIP Power Supply Connections .
3	Use three properly sized wires (AWG #12, 2.5 mm or according to local standards) to connect the line 1, line 2, and ground to the connector block as shown on Figure 5.5 DCX F-EIP Power Supply Connections . Choose wires according to the current rating as specified in Table 5.2 Input Current and Circuit Breaker Specifications and on the label located on the back of the unit. Be sure to use agency approved wiring and use sleeving or tubing on each wire for double insulation.
4	Secure an AWG #12 grounded conductor to the ground screw located next to the air outlet.

Table 5.12 Input Power Connection

Step	Action
5	Connect the converter-booster-horn stack to the power supply using the RF cable. See 5.4.10 Output Power (RF Cable) Connection .
6	Ensure the power of the unit is disconnected. Plug the connector block back into the power supply. Tighten the two securing screws.
7	Connect the power supply to a single-phase, grounded, 3-wire, 50 Hz or 60 Hz 200 V to 230 V power source.

5.5 Power Supply Setup

Certain power supply configurations can be modified from the factory setting if needed. Although not usually requiring modifications from the factory setting, the following features are selectable:

Table 5.13 Power Supply Features

Name	Description
Afterburst	Allows for a short activation of ultrasonics at the end of the weld cycle to reliably release parts from the horn.
Cutoffs	Allows for setting parameter values for immediately terminating a weld cycle: Time (S); Energy (J); Peak Power (%); Frequency Low (Hz); Frequency High (Hz); Custom Input1 (V); and Custom Input2 (v).
End of Weld Store	Provides an option for selecting if the stack frequency is stored at the end of each weld cycle.
Energy Brake	Allows the user to set the power supply to reduce the amplitude before the sonics are shut off.
Frequency Offset	Allows for varying the start frequency by way of external controls (analog signal applied through the user I/O analog input) or setting a fixed value using the web page interface. This is useful for certain applications, where the force applied on the fixture or anvil causes a frequency shift in the stack's operation.
Limits	Allows for setting up limits within a weld mode: +/- Continuous; +/-Time (s); +/- Energy (J); or +/- Peak Power (%).
Mode	Allows for selecting the weld mode from the different available options: Continuous; Time (s); Energy (J); Peak Power (%); and Ground detect.
Power Up	Allows an option to configure the power supply to perform a seek on power up; a horn scan on power up; or to perform no action at power up.
Seek Ramp	Provides a selection for different power supply seek ramp times.
Seek Time	Provides an option for selecting seek duration.
Start Ramp	Provides a selection for different start ramp times. This controls how fast the amplitude of the horn rises from 0 to 100. Long ramp times may be useful when using large horns or high gain stacks.
Timed Seek	Provides an option for monitoring, and storing the operating frequency at timed intervals (60 seconds). Periodic frequency seeks may be helpful when welder is not used for long periods of time. Seeks are timed from the moment sonics was last activated.
Weld Amplitude	Allows for varying the amplitude (10% to 100%) using the front panel LCD, the web page interface, or by way of external controls (analog signal applied through the user I/O analog input). Via the web page interface scrub amplitude, afterburst amplitude, and amplitude stepping options may also be configured.

For instruction on how to change the power supply settings refer to [7.5 Configuring the Power Supply Registers](#) in [Chapter 7: Operation](#).

5.6 Assembling the Acoustic Stack

CAUTION	General Warning
	<p>The following procedure must be performed by a setup person. If necessary, secure the largest portion of a square or rectangular horn in a soft jawed vise. NEVER attempt to assemble or remove a horn by holding the converter housing or the booster clamp ring in a vise.</p>

CAUTION	General Warning
	<p>Do not use silicone grease with Mylar[®] plastic film washers. Use only 1 (one) Mylar[®] plastic film washer of the correct inside and outside diameters at each interface.</p>

NOTICE	
	<p>The use of a Branson torque wrench or the equivalent is recommended. P/N 101-063-787 for 20 kHz, and 30 kHz systems and 101-063-618 for 40 kHz systems.</p>

Figure 5.10 Assembling the Acoustic Stack



Acoustic Stack Description

Table 5.14 Acoustic Stack Description

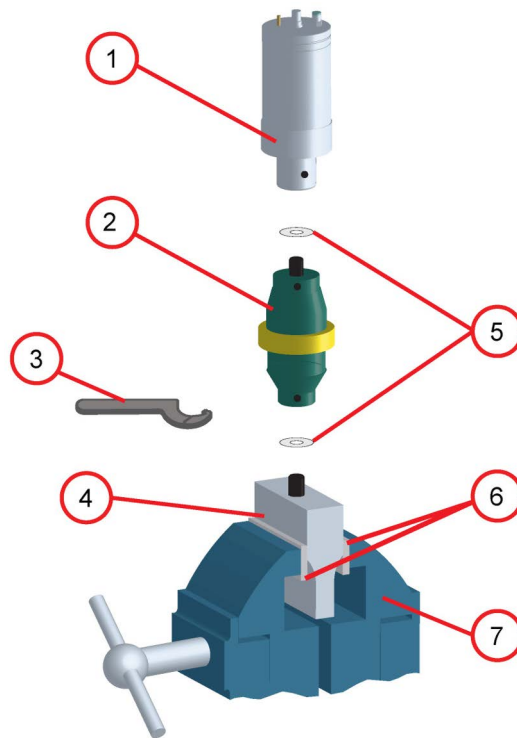
Item	Description
1	Converter
2	Booster
3	Spanner (provided)
4	Horn
5	See stack assembly procedure
6	Vise Jaw protectors (aluminum or soft metal)
7	Vise

Stack Torque Values

Table 5.15 Stack Torque Values

Frequency	Torque
20 kHz	220 in·lb (24.85 N·m)
30 kHz	185 in·lb (21 N·m)
40 kHz	95 in·lb (10.73 N·m)

Tools

Table 5.16 Tools

Tool	EDP Number
20 kHz, and 30 kHz Torque Wrench Kit	101-063-787
40 kHz Torque Wrench	101-063-618
20 kHz Spanner Wrench	101-118-039
30 kHz Spanner Wrench	201-118-033
40 kHz Spanner Wrench	201-118-024
Silicone Grease	101-053-002
Mylar [®] Plastic Film Washers (20 kHz)	100-063-357
Mylar [®] Plastic Film Washers (30 kHz)	100-063-632

5.6.1 For a 20 kHz System

Table 5.17 20 kHz System

Step	Action
1	Ensure that the mating surfaces of the converter, booster, and horn are clean, and that the threaded holes are free of foreign material.
2	Install a single Mylar® plastic film washer (matching the size of the washer to the stud) to each interface.
3	Assemble the converter to the booster and the booster to the horn.
4	Torque to 220 in·lb (24.85 N·m) at each interface.

5.6.2 For a 30 kHz System

Table 5.18 30 kHz System

Step	Action
1	Ensure that the mating surfaces of the converter, booster, and horn are clean, and that the threaded holes are free of foreign material.
2	Install a single Mylar® plastic film washer (matching the size of the washer to the stud) to each interface.
3	Assemble the converter to the booster and the booster to the horn.
4	Torque to 185 in·lb (21 N·m) at each interface.

5.6.3 For a 40 kHz System

Table 5.19 40 kHz System

Step	Action
1	Ensure that the mating surfaces of the converter, booster, and horn are clean, and that the threaded holes are free of foreign material.
2	Coat each interface surface with a thin film of silicon grease - but do not apply silicon grease to a threaded stud or tip.
3	Assemble the converter to the booster and the booster to the horn.
4	Torque to 95 in·lb (10.73 N·m) at each interface.

5.6.4 Connecting Tip to Horn

1. Ensure that the mating surfaces of the tip and horn are clean. Remove any foreign matter from the threaded stud and hole.
2. Hand assemble the tip to the horn. Assemble dry. Do not use any silicone grease.
3. Use the spanner wrench and an open-end wrench (refer to [Figure 5.11 Connecting Tip to Horn](#)) and tighten to the following torque tip specifications:

Figure 5.11 Connecting Tip to Horn

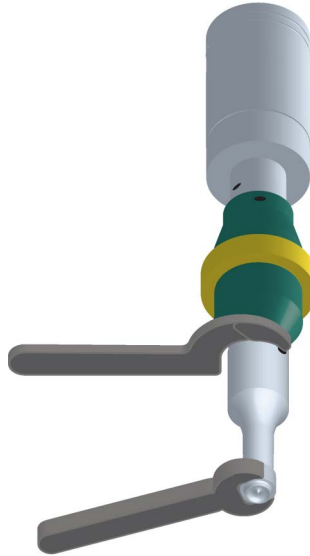

Table 5.20 Tip to horn torque values

Tip Thread	Torque
1/4 - 28	110 in·lbs (12.42 N·m)
3/8 - 24	180 in·lbs (20.33 N·m)

5.7 Converter Cooling

Converter performance and reliability can be adversely affected if the converter ceramics are subjected to temperatures above 140° F (60° C). The converter front driver temperature should not exceed 122° F (50° C).

To prolong converter life and maintain a high degree of system reliability, the converter should be cooled with clean, dry, compressed air, particularly if your application calls for continuous ultrasonic operation. Converter cooling is especially critical in 40 kHz applications.

Use one of the following procedures to determine if a converter is operating close to the maximum allowable temperature. Check converter temperature immediately after substantial machine operation and without power applied to the horn.

- Press a pyrometer probe (or similar temperature measuring device) against the front driver of the converter assembly. Wait for the probe to reach the temperature of the shell. If the temperature is 120° F (49° C) or higher, the converter requires a cooling air stream
- If a temperature measuring device is unavailable, use your hand to feel the shell of the converter. If the converter is hot to touch, the converter requires a cooling air stream

High duty cycles require additional cooling for the converter. System average power must be limited to the specified continuous maximum. Higher peak power, up to the maximum acceptable power limit, with an on time of up to 10 seconds may be obtained, if appropriate off time ensures that, on average, the continuous duty maximum power is not exceeded.

Table 5.21 Continuous Duty Max. Power & Full Power Duty Cycle

Configuration	Continuous Duty Max. Power	Full Power Duty Cycle
20 kHz / 1250 W	375 W	1 s on 2.4 s off (30% Duty Cycle)
20 kHz / 2500 W	750 W	1 s on 2.4 s off (30% Duty Cycle)
20 kHz / 4000 W	1200 W	1 s on 2.4 s off (30% Duty Cycle)
30 kHz / 1500 W	450 W	1 s on 2.4 s off (30% Duty Cycle)
40 kHz / 800 W	240 W	1 s on 2.4 s off (30% Duty Cycle)

If converter cooling is required, use the following steps:

Table 5.22 Converter Cooling Procedure

Step	Action
1	Start with a 50 psi (345 kPa) air source or higher from a 0.06 in (1.5 mm) I.D. orifice
2	Perform a run of welding operations.
3	Immediately after completing the welding run, check the converter temperature.
4	If the converter is still too hot, increase the diameter of the orifice in small increments until the temperature falls within the ranges in the chart.

A 0.06 in (1.5 mm) orifice at 50 psi (345 kPa) will result in a reading of 80 ft³ (2.26 m³) per hour. This should be sufficient to cool most operations requiring a cooling air stream. In continuous welding operations, or applications with longer duty cycles, it may be necessary to cool the horn as well as the converter. Horns may require cooling because of the heat transfer from contacting the work piece.

5.8 Testing the Installation

To test the power supply follow the procedure described in [7.8 Ultrasonics Test Procedure](#) in [Chapter 7: Operation](#).

5.9 Still Need Help?

Branson is pleased that you chose our product and we are here for you! If you need parts or technical assistance with your DCX F-EIP Power Supply system, call your local Branson representative. Please refer to [1.3 How to Contact Branson](#) for a list of Branson key contacts.



Chapter 6: Converters and Boosters

6.1 Converters and Boosters 86

6.1 Converters and Boosters

A variety of converters and boosters available for use with the DCX F-EIP Power Supply are illustrated in the following pages.

WARNING	High Voltage Hazard
	<p>To avoid the possibility of electrical shock, converters need to be properly grounded.</p>

Figure 6.1 20 kHz typical Converter Dimensions

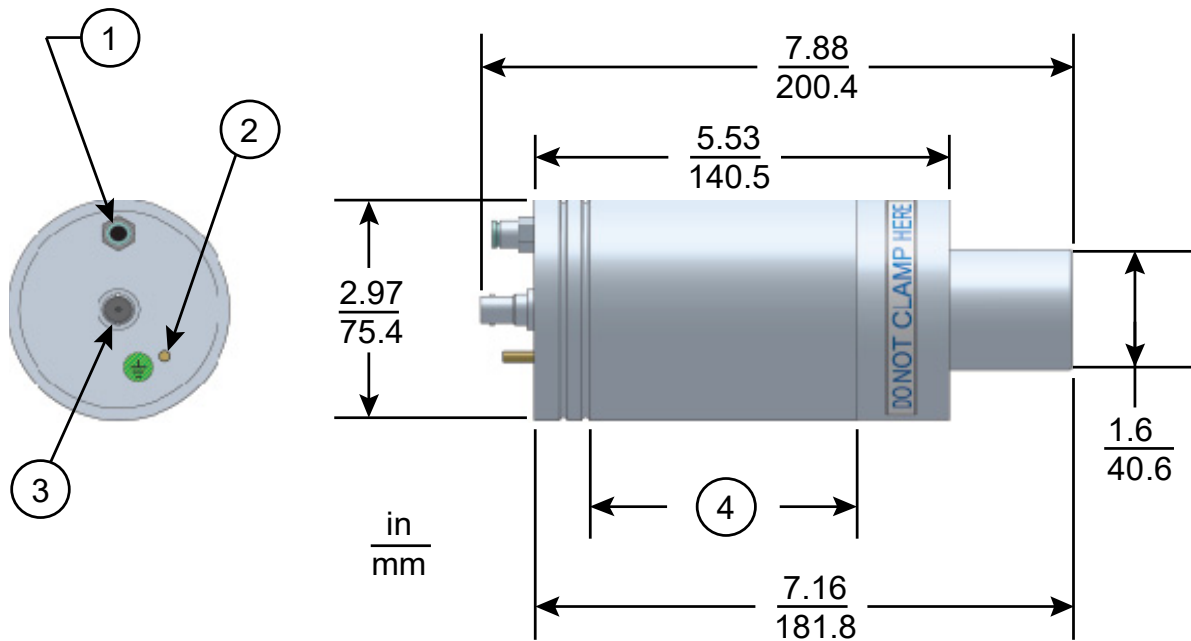

Table 6.1 20 kHz Converter

Item	Description
1	Air inlet
2	Ground stud
3	SHV connector
4	Grip area

Figure 6.2 20 kHz Booster Dimensions

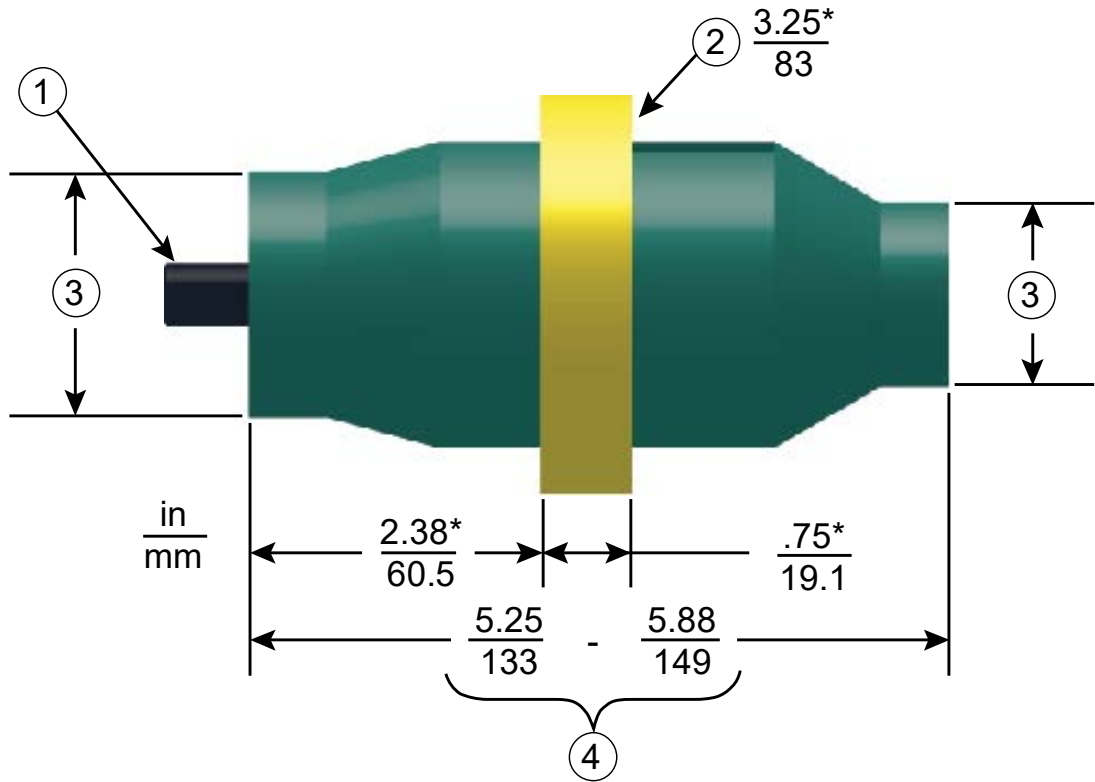

Table 6.2 20 kHz Booster

Item	Description
1	1/2 - 20 x 1 - 1/4 stud (Ti boosters) 1/2 - 20 x 1 - 1/2 stud (Al boosters)
2	Grip Ring Diameter
3	Variable
4	Varies with tuning and gain

* These dimensions do not vary.

Figure 6.3 20 kHz Converter/Booster/Horn, Typical Dimensions

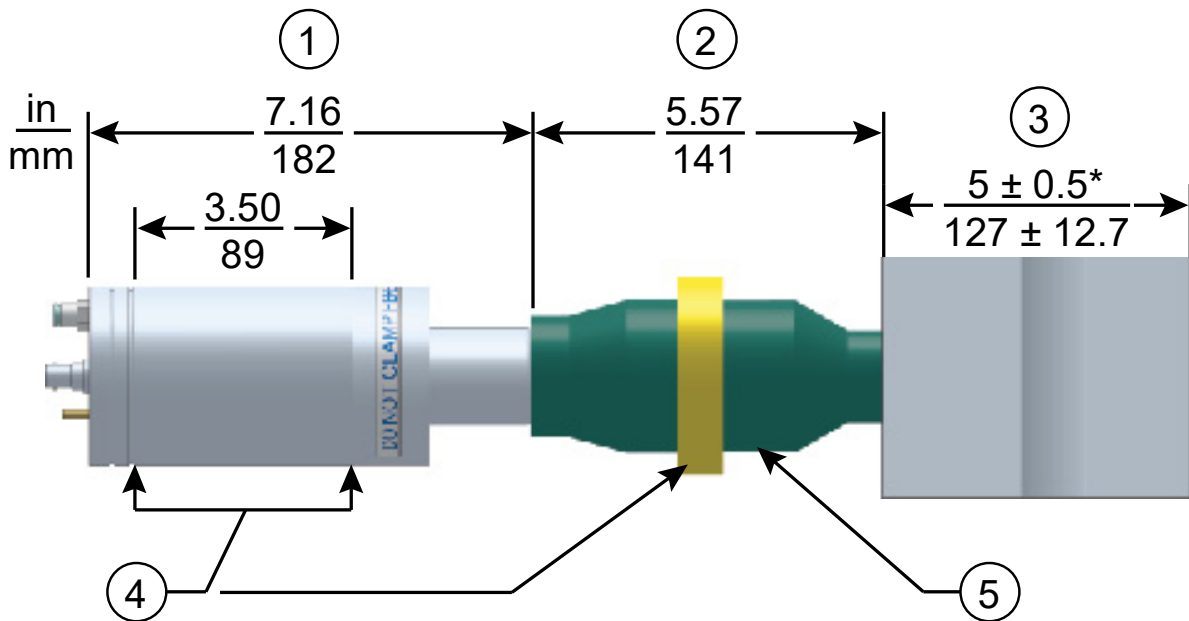

Table 6.3 20 kHz Converter/Booster/Horn

Item	Description
1	Converter
2	Booster
3	One-half wavelength horn
4	Recommended clamping area
5	Booster front end diameter will vary with amplitude

* Overall horn length can vary beyond these typical dimensions depending on the application.

Figure 6.4 30 kHz Converter Dimensions

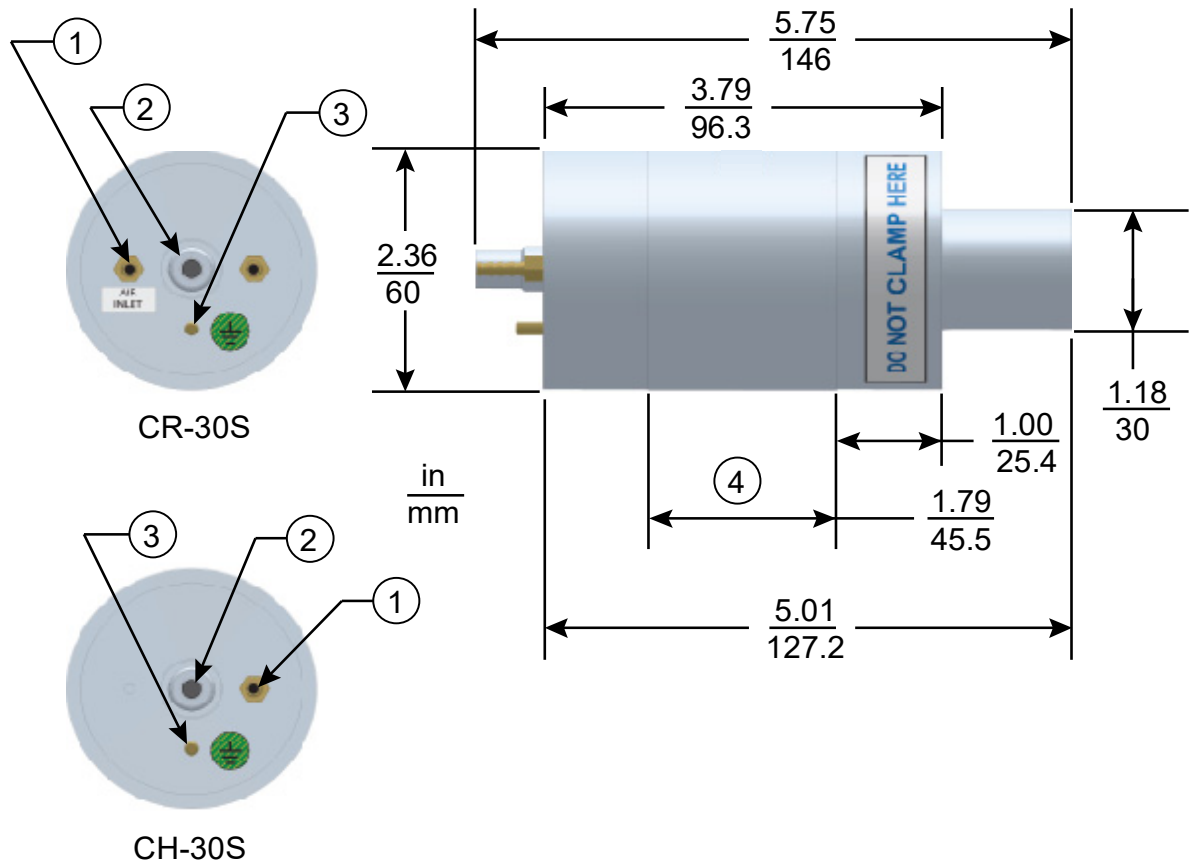

Table 6.4 30 kHz Converter

Item	Description
1	Air inlet
2	SHV connector
3	Ground stud
4	Grip area

CR-30S and CH-30S are dimensionally identical, and differ only in their respective cooling feature.

CR-30S has flow through cooling, and CH-30S has closed loop cooling (air circulates in the converter and returns to its source).

Figure 6.5 30 kHz Booster Dimensions

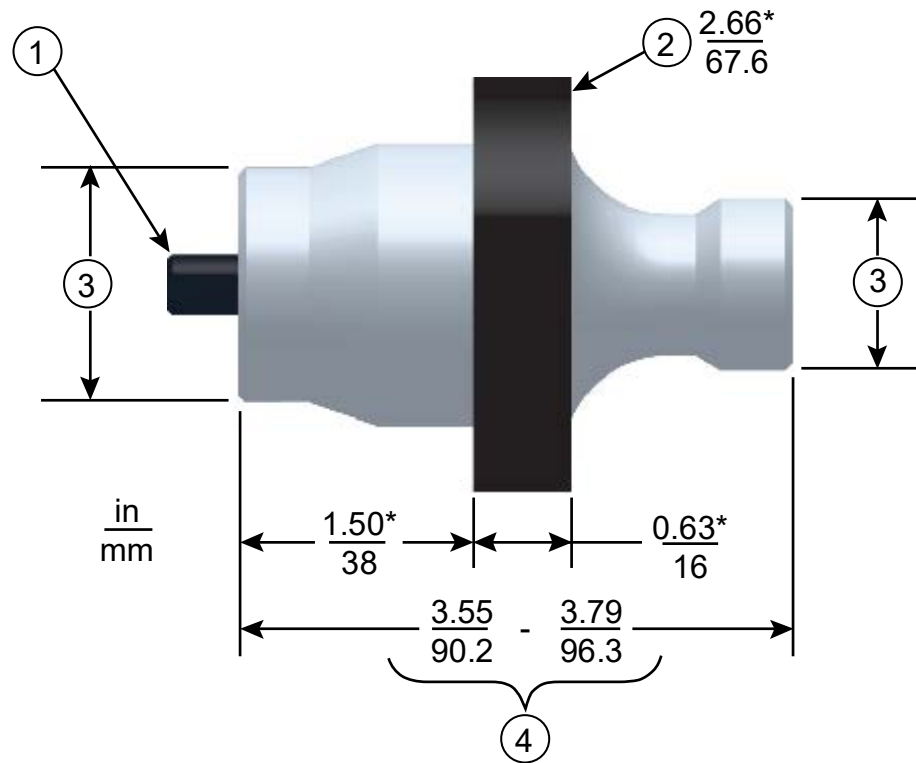

Table 6.5 30 kHz Booster

Item	Description
1	3/8 - 24 x 1 - 1/4 stud
2	Grip Ring Diameter
3	Variable
4	Varies with tuning and gain

* These dimensions do not vary.

Figure 6.6 30 kHz Converter/Booster/Horn, Typical Dimensions

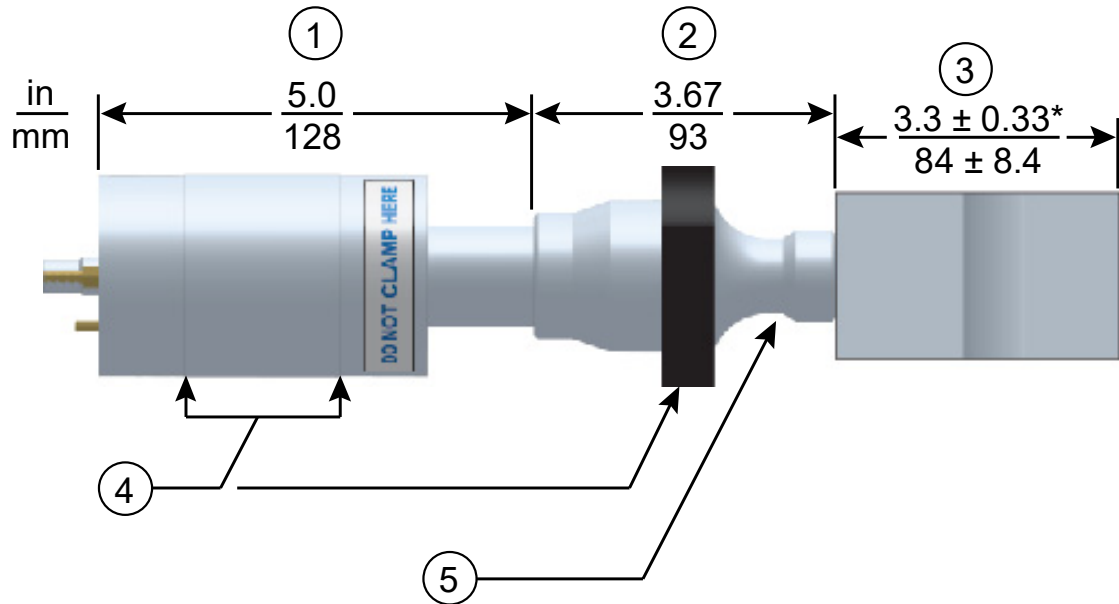

Table 6.6 30 kHz Converter/Booster/Horn

Item	Description
1	Converter
2	Booster
3	One-half wavelength horn
4	Recommended clamping area
5	Booster front end diameter will vary with amplitude

* Overall horn length can vary beyond these typical dimensions depending on the application.

Figure 6.7 40 kHz Booster Dimensions

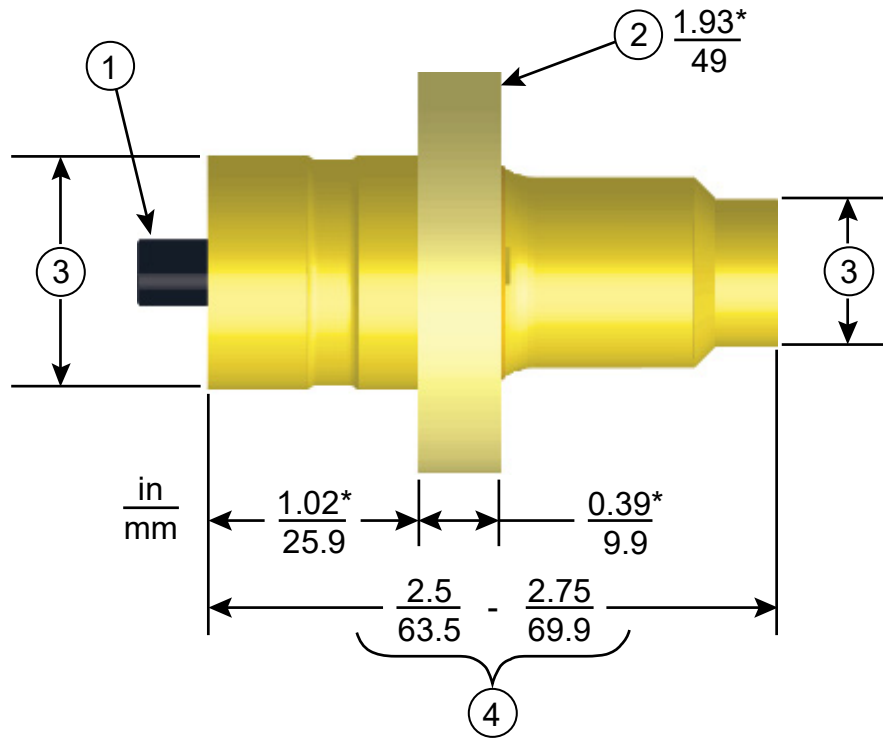

Table 6.7 40 kHz Booster

Item	Description
1	M8 x 1 - 1/4 stud (Ti boosters) M8 x 1 - 1/2 stud (Al boosters)
2	Grip ring diameter
3	Variable
4	Varies with tuning and gain

Figure 6.8 40 kHz Converter/Booster/Horn, Typical Dimensions

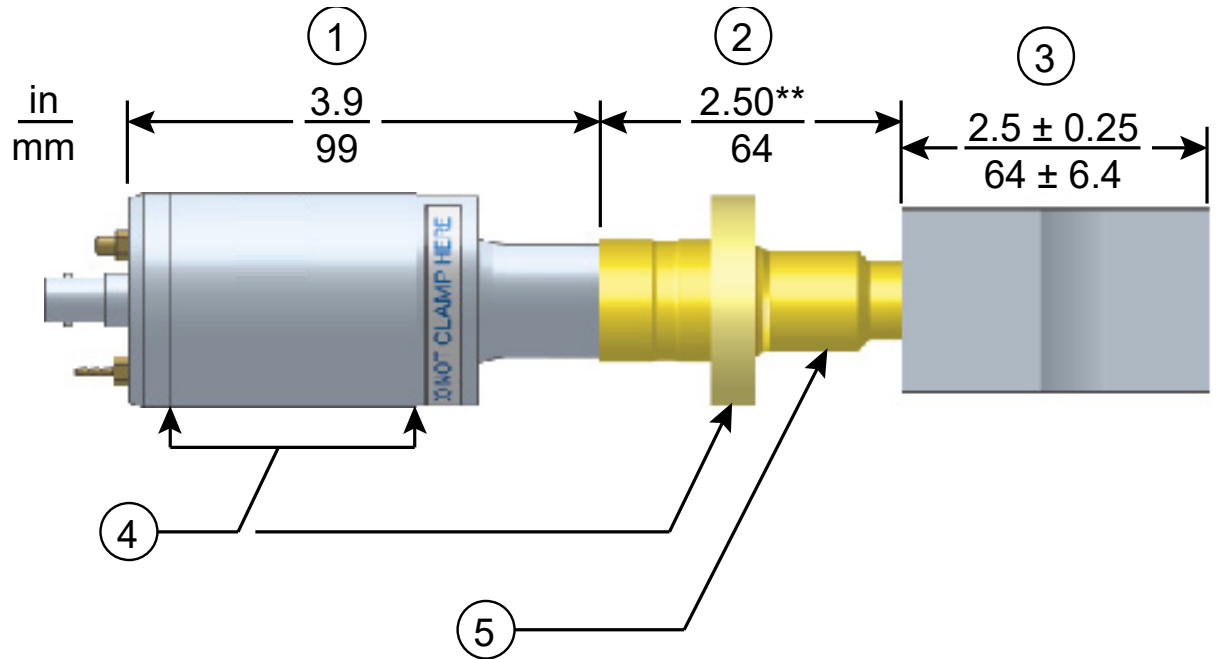

Table 6.8 40 kHz Converter/Booster/Horn

Item	Description
1	Converter
2	Booster
3	One-half wavelength horn
4	Recommended clamping area
5	Booster front end diameter will vary with amplitude

* Overall horn length can vary beyond these typical dimensions depending on the application.

** Dimension varies with tuning and gain.

6.1.1 Component Functional Description

Ultrasonic Stack

Converter

The converter is mounted in the customer's automation as part of the ultrasonic stack. The ultrasonic electrical energy from the power supply is applied to the converter (sometimes called the transducer). This transforms the high frequency electrical oscillations into mechanical vibrations at the same frequency as the electrical oscillations. The heart of the converter are piezoelectric ceramic elements. When subjected to an alternating voltage, these elements alternately expand and contract, resulting in better than 90% conversion of electrical to mechanical energy.

Booster

It is important to be able to modify the horn face amplitude for successful ultrasonic assembly. The booster provides a means to modify the amplitude. It is designed to couple different ratios of ultrasonic energy to the horn, which will in turn increase or decrease the amplitude at the face of the horn. This is accomplished by varying the ratios of the masses of the input and output half sections of the booster.

The booster is a resonant half-wave section of aluminum or titanium. It is mounted between the converter and the horn, as part of the ultrasonic stack. It also provides a clamping point for rigid stack mounting.

Horn

The horn is selected or designed for a specific application. Each horn is tuned typically as a half-wave section that applies the necessary force and vibration uniformly to the parts to be assembled. It transfers ultrasonic vibrations from the converter to the workpiece. The horn is mounted to the booster as part of the ultrasonic stack.

Depending on their profile, horns are referred to as stepped, conical, exponential, bar, or catenoidal. The shape of the horn determines the amplitude at the face of the horn. Depending on the application, horns can be made from titanium alloys, aluminum, or steel. Titanium alloys are the best materials for horn fabrication due to their high level of strength and low loss. Aluminum horns are usually chrome- or nickel-plated or hard-coated to reduce wear. Steel horns are for low amplitude requiring hardness, such as ultrasonic insertion applications.

Solid Mount Boosters

The solid mount booster is a one-half wave-length resonant section made exclusively of titanium. It is mounted between the converter and the horn, modifying the amplitude of vibration applied to the horn and providing a clamping point.

The solid mount booster is superior to prior versions in that deflection is minimized. This is the result of a redesigned clamp-ring which employs a metal-to-metal press fit rather than an O-ring assembly.

The advantage this booster offers is its improved rigidity. For continuous applications, this means more energy delivered to the product, while in plunge applications, improved alignment is possible. The solid mount provides improved positional alignment and will benefit continuous applications where high force, high side load, or high cycle rates are necessary. In plunge welding applications, overall deflection is reduced by an average of 0.0025 in. (0.064 mm) over a wide variety of materials, joint designs, and operating conditions. The results of this testing in combination with information drawn from field testing indicate that the solid mount will benefit plunge applications where precision alignment is necessary (such as staking, swaging, or insertion) or where concentricity/parallelism is critical.



Chapter 7: Operation

7.1	Setting Primary Parameters	98
7.2	Setting Limits	109
7.3	Setting the Amplitude	122
7.4	Resetting the Power Supply Alarms	124
7.5	Configuring the Power Supply Registers	125
7.6	Save/Recall Presets	130
7.7	LCD Bar-Graph	133
7.8	Ultrasonics Test Procedure	136
7.9	Using the I/O Connections	138

7.1 Setting Primary Parameters

After analyzing your specific application, you can determine the Weld Mode to use to weld your parts. A Weld Mode is a set of parameters that governs the weld. Contact the Branson Ultrasonics Applications Laboratory for more information on determining the best mode for welding your application. See [1.3 How to Contact Branson](#).

There are five Weld Modes to choose from Continuous, Time, Energy, Peak Power, and Ground Detect Modes. The following table describes each mode:

Table 7.1 Summary of Weld Modes

Weld Mode	Description
Continuous	On this mode, ultrasonic energy will be delivered continuously while the start signal is present.
Time	You select the length of time (in seconds) that ultrasonic energy will be transmitted to your parts.
Energy	You select the amount of energy (in Joules) that will be transmitted to your parts. (A Joule is one Watt-Second.)
Peak Power	You select the peak power level (as a percentage of full power) at which the weld is terminated.
Ground Detect	<p>The DCX F-EIP Power Supply provides ultrasonic energy until the horn comes in contact with your electrically isolated fixture or with the anvil, providing that you made an electrical connection between the actuator and your fixture or anvil.</p> <p>NOTICE Ground detect signal is required to terminate the weld and enter scrub time.</p>

NOTICE	
	In these modes, cutoffs can be used as secondary controls.

7.1.1 Continuous Mode

In this mode, ultrasonic energy will be delivered continuously while the start signal is present. Within Continuous Mode, you can also select several other parameters, ranging from afterburst to limits and cutoffs. For more information on setting the optional parameters within Continuous Mode, or any other welding mode, refer to the DCX A/F Series Web Page Instruction Manual.

Table 7.2 Continuous Mode Operational Sequence





Step	Action	Reference
1	<p>Press the Configuration key until the number icon (#) appears on the LCD.</p> <p>The power supply will display register 101 at every power up.</p>	 <p>The image shows a digital LCD display with the number '101' in large digits. Above the digits, a '#' icon is highlighted. The display also shows various status icons at the top and bottom, including a lightning bolt, a battery level indicator, and a star. A hand is shown pressing the Configuration key (the one with the '#' icon) on the control panel below the display.</p>
2	<p>Press and release the Up/Down arrow keys to select register 138. For a detailed description of available registers refer to Table 7.26 Power Supply Registers.</p>	 <p>The image shows the same digital LCD display, but now the number '138' is displayed. The Up/Down arrow keys on the control panel are highlighted with a hand, indicating they have been used to navigate to register 138.</p>
3	<p>Once you have reached register 138, press the Configuration key. The register value will be displayed; this is indicated by the circle icon.</p>	 <p>The image shows the digital LCD display with the number '138' displayed. A small circle icon is now highlighted above the number. The Configuration key on the control panel is shown being pressed by a hand.</p>

Table 7.2 Continuous Mode Operational Sequence

Step	Action	Reference
4	Use the Up/Down arrow keys to select value 0 (Continuous mode), then press the Configuration key to confirm the selection.	 <p>The screenshot shows the device's LCD screen with a digital display showing '00:00'. Above the display are several icons including an infinity symbol, a clock, a fan, a left arrow, a right arrow, a circle with a vertical line, a hash symbol, a percent sign, and 'JS'. Below the display is a battery level indicator and a star icon. At the bottom of the screen is a control panel with four buttons: a red downward-pointing triangle, a button with a crossed-out lightning bolt, a button with a gear icon (being pressed by a hand), and a button with a lightning bolt and a red signal icon. A red upward-pointing triangle is on the far right.</p>
5	Continuous mode icon and amplitude value will be displayed.	 <p>The screenshot shows the device's LCD screen with a digital display showing '100'. The infinity symbol icon at the top left of the screen is now highlighted. The rest of the interface, including the battery indicator, star icon, and control panel, remains the same as in the previous step.</p>

7.1.2 Time Mode

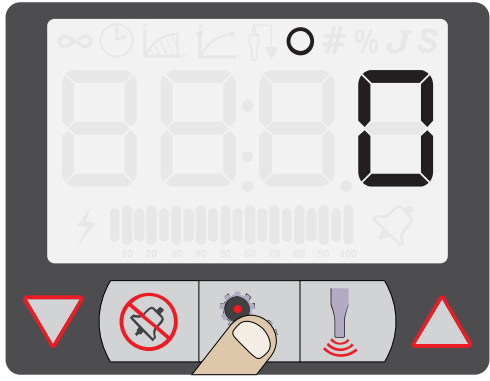
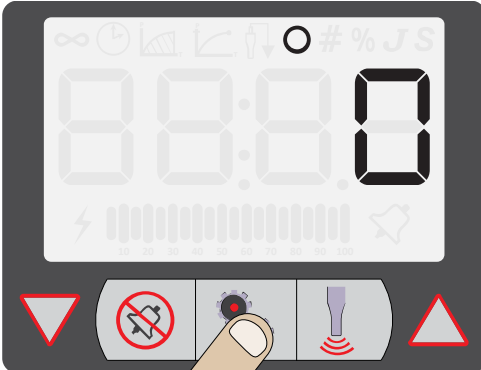
You can use Time Mode to select the length of time that ultrasonic energy is applied to your parts. Within Time Mode, you can also select several other parameters, ranging from afterburst to limits and cutoffs. For more information on setting the optional parameters within Time Mode, or any other welding mode, refer to the DCX A/F Series Web Page Instruction Manual.

Table 7.3 Time Mode Parameters

Parameter	Default	Max. Value	Min. Value
Time	0.010 seconds	30 seconds	0.010 seconds

Table 7.4 Time Mode Operational Sequence



Step	Action	Reference
1	Press the Configuration key until the number icon (#) appears on the LCD. The power supply will display register 101 at every power up.	 <p>The image shows a digital LCD display with a grid of icons at the top. The main display area shows the number '101'. Below the display is a control panel with several buttons: a left-pointing triangle, a button with a crossed-out lightning bolt, a button with a red dot, a button with a lightning bolt and sound waves, and a right-pointing triangle. A finger is shown pressing the button with the red dot.</p>
2	Press and release the Up/Down arrow keys to select register 138. For a detailed description of available registers refer to Table 7.26 Power Supply Registers .	 <p>The image shows the same digital LCD display as in step 1, but now the main display area shows the number '138'. The control panel is the same, but a finger is shown pressing the right-pointing triangle button.</p>

Table 7.4 Time Mode Operational Sequence

Step	Action	Reference
3	Once you have reached register 138, press the Configuration key. The register value will be displayed; this is indicated by the circle icon.	
4	Use the Up/Down arrow keys to select value 1 (Time mode), then press the Configuration key to confirm the selection.	
5	Time mode icon and parameter value will be displayed. Use the Up/Down keys to enter the desired parameter value, then press the Configuration key to confirm the selected value.	

7.1.3 Energy Mode

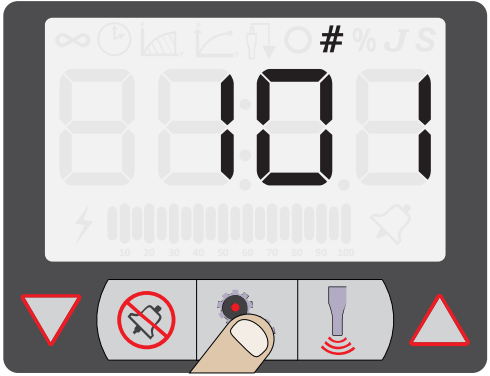
You can use Energy Mode to select the amount of ultrasonic energy that is applied to your parts. Within Energy Mode, you can also select several other parameters, ranging from afterburst to limits and cutoffs. For more information on setting the optional parameters within Energy Mode, or any other welding mode, refer to the DCX A/F Series Web Page Instruction Manual.

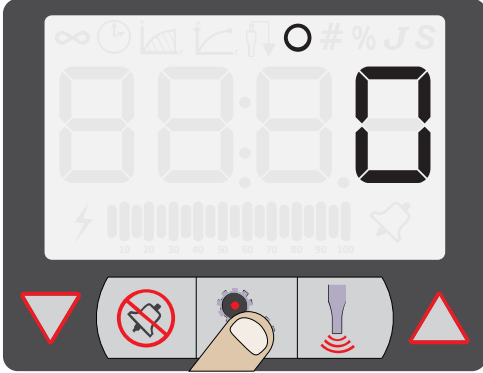
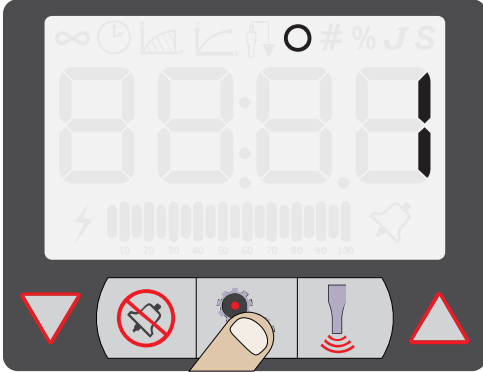
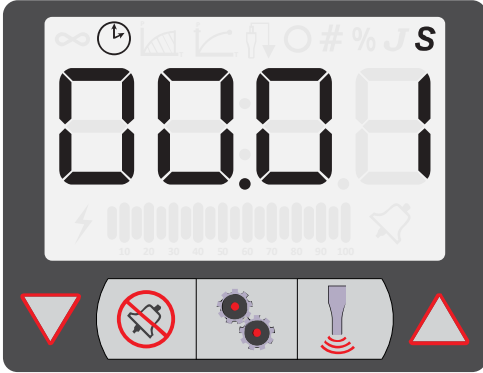
Table 7.5 Energy Mode Parameters

Parameter	Default	Max. Value	Min. Value
Energy	500 Joules	9999 Joules	0.1 Joules

Table 7.6 Energy Mode Operational Sequence





Step	Action	Reference
1	<p>Press the Configuration key until the number icon (#) appears on the LCD.</p> <p>The power supply will display register 101 at every power up.</p>	 <p>The image shows the LCD display with the number '101' in the center. Above the number is a '#' icon. The display also shows various icons at the top and bottom, including a power button, a warning icon, and a configuration icon. A hand is shown pressing the configuration icon.</p>
2	<p>Press and release the Up/Down arrow keys to select register 138. For a detailed description of available registers refer to Table 7.26 Power Supply Registers.</p>	 <p>The image shows the LCD display with the number '138' in the center. Above the number is a '#' icon. The display also shows various icons at the top and bottom, including a power button, a warning icon, and a configuration icon. A hand is shown pressing the up/down arrow keys.</p>

Table 7.6 Energy Mode Operational Sequence

Step	Action	Reference
3	Once you have reached register 138, press the Configuration key. The register value will be displayed; this is indicated by the circle icon.	 <p>The screenshot shows a digital display with '0' on the right. Above the '0' is a circle icon. The bottom control panel shows a hand pressing the central Configuration key (a red dot with a circle around it).</p>
4	Use the Up/Down arrow keys to select value 2 (Energy mode), then press the Configuration key to confirm the selection.	 <p>The screenshot shows a digital display with '2' on the right. Above the '2' is a circle icon. The bottom control panel shows a hand pressing the central Configuration key.</p>
5	Energy mode icon and parameter value will be displayed. Use the Up/Down keys to enter the desired parameter value, then press the Configuration key to confirm the selected value.	 <p>The screenshot shows a digital display with '500' on the right. Above the '500' is an energy mode icon (a lightning bolt with a circle around it). The bottom control panel shows a hand pressing the central Configuration key.</p>

7.1.4 Peak Power Mode

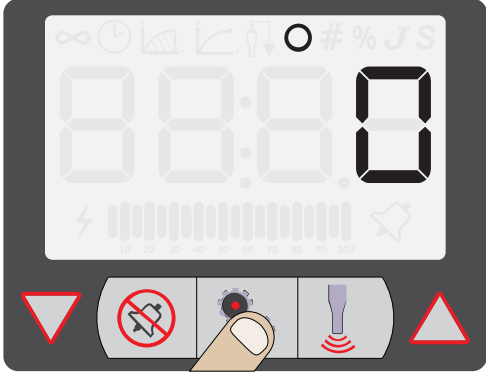
You can use Peak Power Mode to select the maximum percentage of the total available power that will be used to process your welds. When the power level you set is reached, ultrasonics will be terminated. From within Peak Power Mode, you can also select several other parameters, ranging from afterburst to limits and cutoffs. For more information on setting the optional parameters within Peak Power Mode, or any other welding mode, refer to the DCX A/F Series Web Page Instruction Manual.

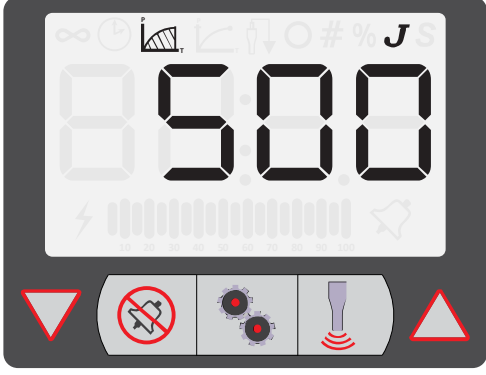
Table 7.7 Peak Power Mode Parameters

Parameter	Default	Max. Value	Min. Value
Peak Power	1%	100%	1%

Table 7.8 Peak Power Mode Operational Sequence

Step	Action	Reference
1	Press the Configuration key until the number icon (#) appears on the LCD. The power supply will display register 101 at every power up.	 <p>The image shows the LCD display with the number '101' in the center. Above the number is a '#' icon. The display also shows various icons at the top and bottom, including a power icon, a warning icon, and a configuration icon. A hand is shown pressing the configuration key.</p>
2	Press and release the Up/Down arrow keys to select register 138. For a detailed description of available registers refer to Table 7.26 Power Supply Registers .	 <p>The image shows the LCD display with the number '138' in the center. Above the number is a '#' icon. The display also shows various icons at the top and bottom, including a power icon, a warning icon, and a configuration icon. A hand is shown pressing the up/down arrow keys.</p>

Table 7.8 Peak Power Mode Operational Sequence

Step	Action	Reference
3	Once you have reached register 138, press the Configuration key. The register value will be displayed; this is indicated by the circle icon.	
4	Use the Up/Down arrow keys to select value 3 (Peak Power mode), then press the Configuration key to confirm the selection.	
5	Peak Power mode icon and parameter value will be displayed. Use the Up/Down keys to enter the desired parameter value, then press the Configuration key to confirm the selected value.	

7.1.5 Ground Detect Mode

You can use Ground Detect Weld Mode to have ultrasonic energy turn off when the horn comes in contact with your electrically isolated fixture or anvil.

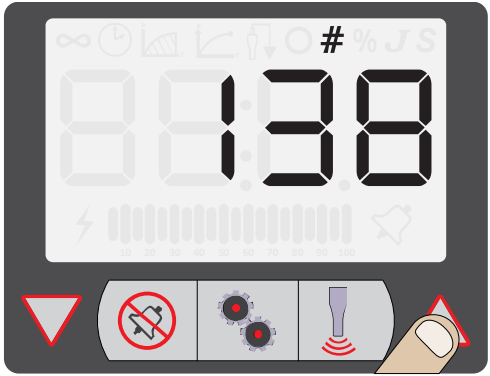
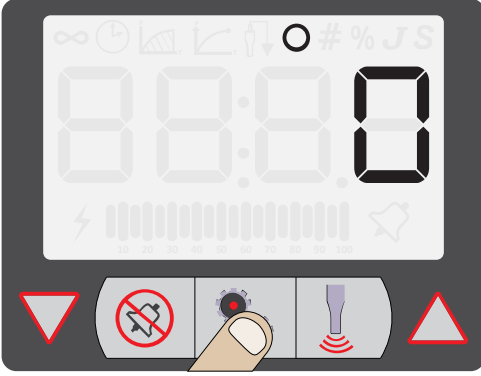
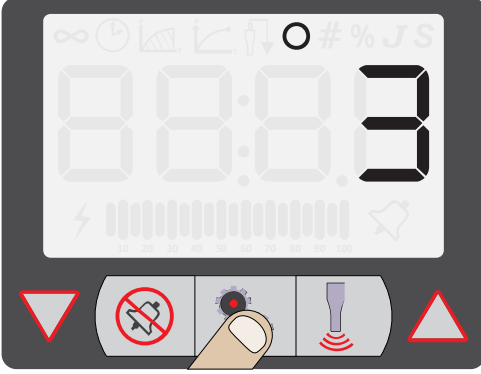
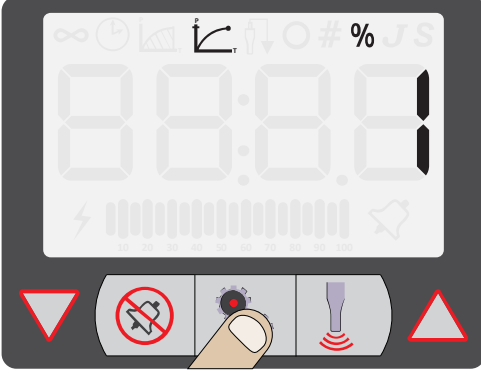
From within Ground Detect Mode, you can also select several other parameters, ranging from Hold Time (in seconds) to Suspect and Reject Limits. For more information on setting the optional parameters within Ground Detect Mode, or any other welding mode, refer to the DCX A/F Series Web Page Instruction Manual.

Table 7.9 Ground Detect Mode Parameters

Parameter	Default	Max. Value	Min. Value
Ground Detect	0.001 seconds	0.500 seconds	0.001 seconds

Table 7.10 Ground Detect Mode Operational Sequence



Step	Action	Reference
1	Press the Configuration key until the number icon (#) appears on the LCD. The power supply will display register 101 at every power up.	 <p>The image shows a close-up of the power supply's LCD screen. The screen displays the number '101' in large digits. Above the digits, there are several icons, including a '#' symbol. Below the screen, there are four physical buttons: a left-pointing triangle, a button with a crossed-out lightning bolt, a button with a red light indicator, and a right-pointing triangle. A finger is shown pressing the right-pointing triangle button.</p>
2	Press and release the Up/Down arrow keys to select register 138. For a detailed description of available registers refer to Table 7.26 Power Supply Registers .	 <p>The image shows a close-up of the power supply's LCD screen. The screen displays the number '138' in large digits. Above the digits, there are several icons, including a '#' symbol. Below the screen, there are four physical buttons: a left-pointing triangle, a button with a crossed-out lightning bolt, a button with a red light indicator, and a right-pointing triangle. A finger is shown pressing the right-pointing triangle button.</p>

Table 7.10 Ground Detect Mode Operational Sequence

Step	Action	Reference
3	Once you have reached register 138, press the Configuration key. The register value will be displayed; this is indicated by the circle icon.	
4	Use the Up/Down arrow keys to select value 4 (Ground Detect mode), then press the Configuration key to confirm the selection.	
5	Ground Detect mode icon and parameter value will be displayed. Use the Up/Down keys to enter the desired parameter value, then press the Configuration key to confirm the selected value.	

7.2 Setting Limits

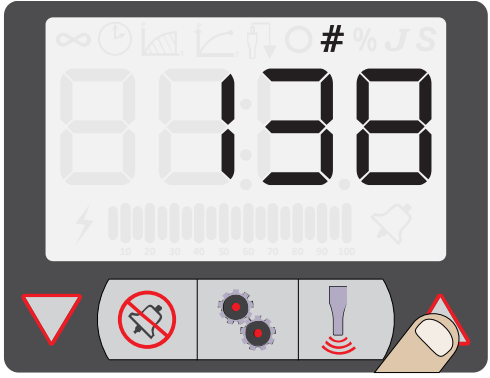
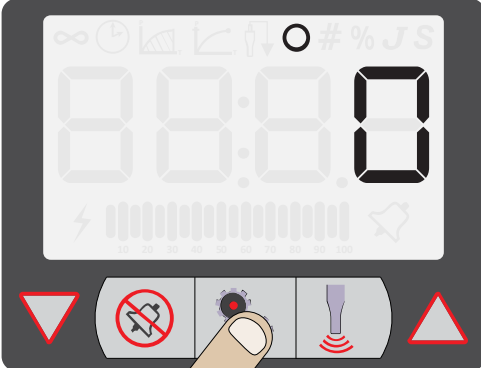
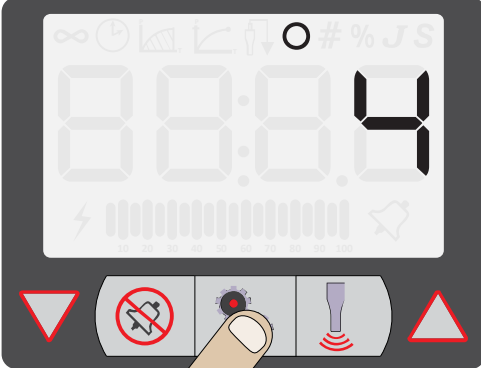
NOTICE	
	Register 114 (Limits) must be set to On before proceeding. See 7.5 Configuring the Power Supply Registers for more information.

7.2.1 Time Window Limit High

Table 7.11 Time Window Limit High Parameters

Parameter	Default	Max. Value	Min. Value
Time Window Limit High	30.00s	30.00s	0.010s

NOTICE	
	Minimum value should be higher than the window limit low value.

NOTICE	
	Set value to 0 to set the window limit high to off.



NOTICE	
	Time window limits must be set in multiples of 1.

Table 7.12 Time Window Limit High Operational Sequence

Step	Action	Reference
1	<p>Press the Configuration key until the number icon (#) appears on the LCD.</p> <p>The power supply will display register 101 at every power up.</p>	 <p>The LCD display shows the number '101' in a large digital font. Above the numbers is a '#' icon. The display also shows various status icons at the top and bottom, including a lightning bolt, a battery level indicator, and a warning icon.</p>
2	<p>Press and release the Up/Down arrow keys to select register 158. For a detailed description of available registers refer to Table 7.26 Power Supply Registers.</p>	 <p>The LCD display shows the number '158' in a large digital font. Above the numbers is a '#' icon. The display also shows various status icons at the top and bottom, including a lightning bolt, a battery level indicator, and a warning icon.</p>
3	<p>Once you have reached register 158, press the Configuration key. The register value will be displayed; this is indicated by the circle icon.</p> <p>Use the Up/Down arrow keys to select the desired time window limit high value, then press the Configuration key to confirm the selection.</p> <p>NOTICE Register 114 (Limits) must be set to On before proceeding. Otherwise, the value of the limits cannot be changed.</p>	 <p>The LCD display shows the value '30.00' in a large digital font. Above the numbers is a circle icon. The display also shows various status icons at the top and bottom, including a lightning bolt, a battery level indicator, and a warning icon.</p>

7.2.2 Time Window Limit Low

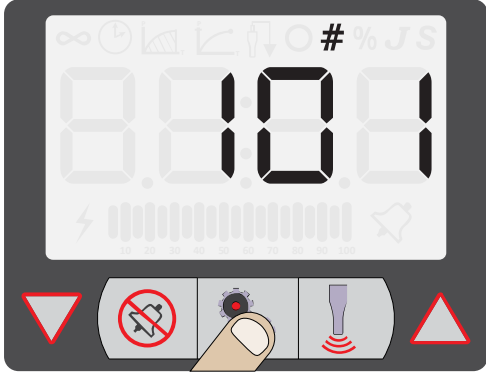
Table 7.13 Time Window Limit Low Parameters

Parameter	Default	Max. Value	Min. Value
Time Window Limit Low	0s	30.00s	0.010s

NOTICE



Maximum value should be lower than the window limit high value.

NOTICE





Set value to 0 to set the window limit high to off.

NOTICE

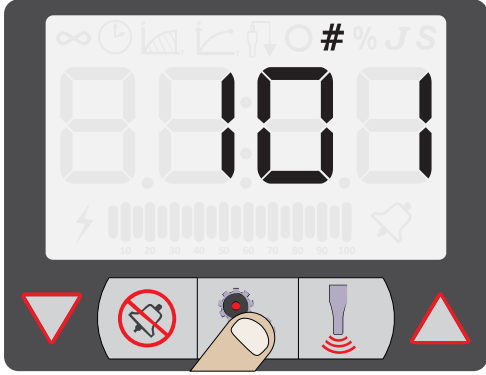

Time window limits must be set in multiples of 1.

Table 7.14 Time Window Limit Low Operational Sequence

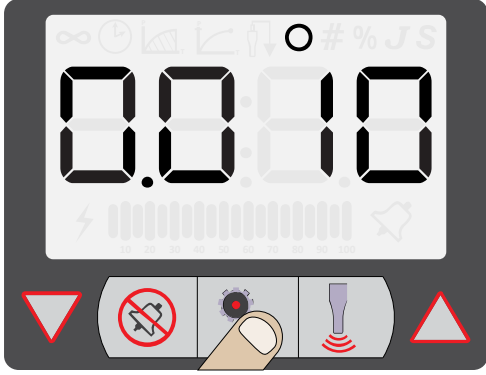
Step	Action	Reference
1	<p>Press the Configuration key until the number icon (#) appears on the LCD.</p> <p>The power supply will display register 101 at every power up.</p>	
2	<p>Press and release the Up/Down arrow keys to select register 159. For a detailed description of available registers refer to Table 7.26 Power Supply Registers.</p>	
3	<p>Once you have reached register 159, press the Configuration key. The register value will be displayed; this is indicated by the circle icon.</p> <p>Use the Up/Down arrow keys to select the desired time window limit low value, then press the Configuration key to confirm the selection.</p> <p>NOTICE Register 114 (Limits) must be set to On before proceeding. Otherwise, the value of the limits cannot be changed.</p>	

7.2.3 Energy Window Limit High

Table 7.15 Energy Window Limit High Parameters

Parameter	Default	Max. Value	Min. Value
Energy Window Limit High	0J	9999J	0.1J

NOTICE



Minimum value should be higher than the window limit low value.

NOTICE





Set value to 0 to set the window limit high to off.

NOTICE

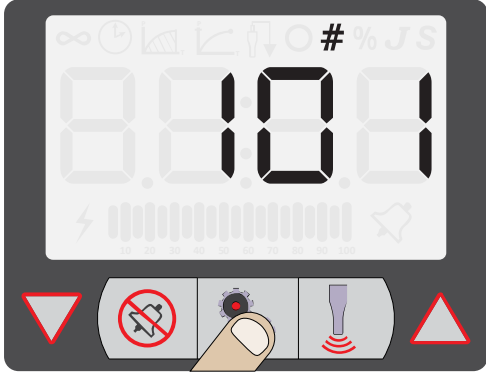

Energy window limits must be set in multiples of 1.

Table 7.16 Energy Window Limit High Operational Sequence

Step	Action	Reference
1	<p>Press the Configuration key until the number icon (#) appears on the LCD.</p> <p>The power supply will display register 101 at every power up.</p>	
2	<p>Press and release the Up/Down arrow keys to select register 160. For a detailed description of available registers refer to Table 7.26 Power Supply Registers.</p>	
3	<p>Once you have reached register 160, press the Configuration key. The register value will be displayed; this is indicated by the circle icon.</p> <p>Use the Up/Down arrow keys to select the desired energy window limit high value, then press the Configuration key to confirm the selection.</p> <p>NOTICE Register 114 (Limits) must be set to On before proceeding. Otherwise, the value of the limits cannot be changed.</p>	

7.2.4 Energy Window Limit Low

Table 7.17 Energy Window Limit Low Parameters

Parameter	Default	Max. Value	Min. Value
Energy Window Limit Low	0J	9999J	0.1J

NOTICE



Maximum value should be lower than the window limit high value.

NOTICE





Set value to 0 to set the window limit high to off.

NOTICE



Energy window limits must be set in multiples of 1.

Table 7.18 Energy Window Limit Low Operational Sequence

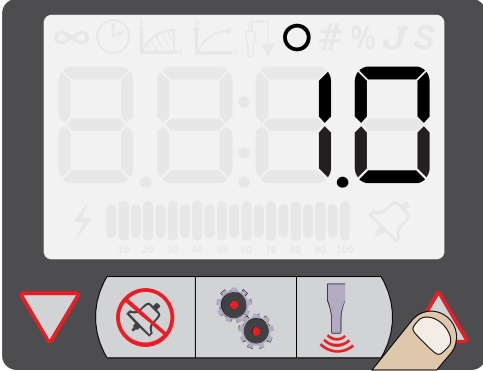
Step	Action	Reference
1	<p>Press the Configuration key until the number icon (#) appears on the LCD.</p> <p>The power supply will display register 101 at every power up.</p>	
2	<p>Press and release the Up/Down arrow keys to select register 161. For a detailed description of available registers refer to Table 7.26 Power Supply Registers.</p>	
3	<p>Once you have reached register 161, press the Configuration key. The register value will be displayed; this is indicated by the circle icon.</p> <p>Use the Up/Down arrow keys to select the desired energy window limit low value, then press the Configuration key to confirm the selection.</p> <p>NOTICE Register 114 (Limits) must be set to On before proceeding. Otherwise, the value of the limits cannot be changed.</p>	

7.2.5 Setting Power Window Limits

If power window high or power window low limits are enabled, it will display a single slowly blinking segment for the high limit and a single slowly blinking segment for the low limit in the bar-graph. In case of a window limit alarm, the respective segment will blink faster.

Figure 7.1 Power Window Limits

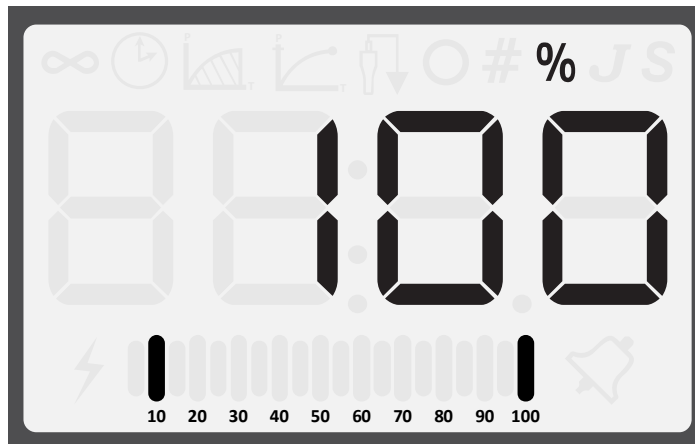

7.2.6 Power Window Limit High

Table 7.19 Power Window Limit High Parameters

Parameter	Default	Max. Value	Min. Value
Power Window Limit High	0%	100%	1%

NOTICE	
	Minimum value should be higher than the window limit low value.

NOTICE	
	Set value to 0 to set the window limit high to off.



NOTICE	
	Power window limits must be set in multiples of 1.

Table 7.20 Power Window Limit High Operational Sequence

Step	Action	Reference
1	<p>Press the Configuration key until the number icon (#) appears on the LCD.</p> <p>The power supply will display register 101 at every power up.</p>	 <p>The image shows a digital LCD display with the number '101' in the center. Above the number, the '#' icon is highlighted. The display also shows various status icons at the top and bottom, including a lightning bolt, a battery level indicator, and a warning icon.</p>
2	<p>Press and release the Up/Down arrow keys to select register 162. For a detailed description of available registers refer to Table 7.26 Power Supply Registers.</p>	 <p>The image shows the LCD display with the number '162' in the center. The '#' icon is still present. The Up/Down arrow keys on the physical keypad are highlighted with a finger, indicating they have been used to navigate to this register.</p>
3	<p>Once you have reached register 162, press the Configuration key. The register value will be displayed; this is indicated by the circle icon.</p> <p>Use the Up/Down arrow keys to select the desired power window limit high value, then press the Configuration key to confirm the selection.</p> <p>NOTICE Register 114 (Limits) must be set to On before proceeding. Otherwise, the value of the limits cannot be changed.</p>	 <p>The image shows the LCD display with the number '162' in the center. A small circle icon is now highlighted above the number, indicating that the Configuration key has been pressed. The physical keypad also shows the Configuration key (a gear icon) being pressed.</p>

7.2.7 Power Window Limit Low

Table 7.21 Power Window Limit Low Parameters

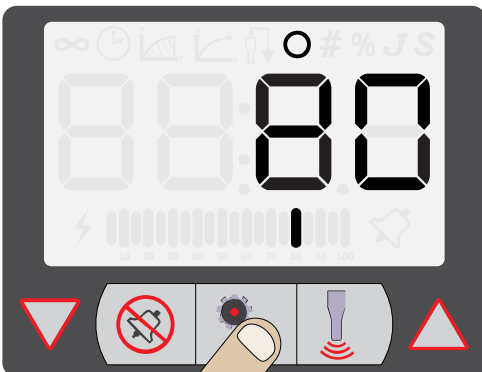
Parameter	Default	Max. Value	Min. Value
Power Window Limit Low	0%	100%	1%

NOTICE	
	Maximum value should be lower than the window limit high value.

NOTICE	
	Set value to 0 to set the window limit high to off.



NOTICE	
	Power window limits must be set in multiples of 1.

Table 7.22 Power Window Limit Low Operational Sequence

Step	Action	Reference
1	<p>Press the Configuration key until the number icon (#) appears on the LCD.</p> <p>The power supply will display register 101 at every power up.</p>	
2	<p>Press and release the Up/Down arrow keys to select register 163. For a detailed description of available registers refer to Table 7.26 Power Supply Registers.</p>	
3	<p>Once you have reached register 163, press the Configuration key. The register value will be displayed; this is indicated by the circle icon.</p> <p>Use the Up/Down arrow keys to select the desired power window limit low value, then press the Configuration key to confirm the selection.</p> <p>NOTICE Register 114 (Limits) must be set to On before proceeding. Otherwise, the value of the limits cannot be changed.</p>	

7.2.8 Using the Web Page Interface

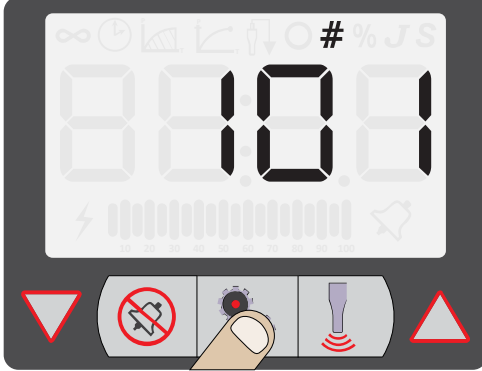
Window limits can be set to a user specified value using the web page interface. For more information, refer to the DCX A/F Rack Mount Series Web Page Interface Instruction Manual.

7.3 Setting the Amplitude

7.3.1 Using the Front Panel Controls

At power up the DCX F-EIP Power Supply will display the last amplitude setting on the LCD. It can also be set to show weld mode.

Figure 7.2 LCD at Power Up

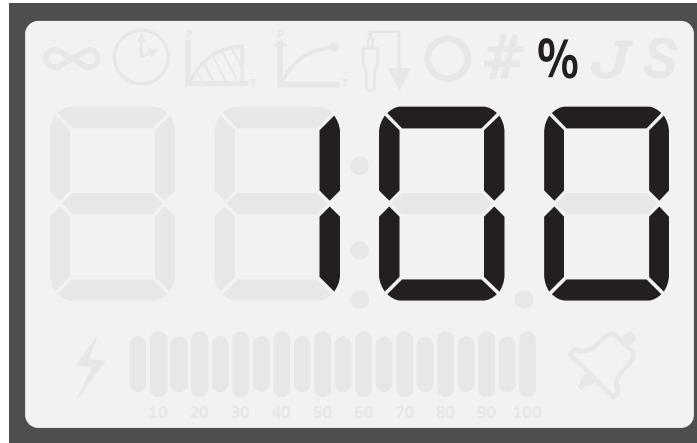

Table 7.23 Setting the Amplitude Using the Front Panel Controls

Step	Action	Reference
1	Press the Configuration key until the percentage icon (%) and no mode icons are displaying on the LCD.	
2	<p>Press and release the Up or Down arrow keys to select the desired amplitude at 1% increments.</p> <p>Press and hold down the Up or Down arrow keys and the Amplitude will auto increment at 1% increments every quarter of a second.</p> <p>After holding down an arrow key for four straight seconds, the amplitude will auto increment at 5% increments every quarter of a second.</p>	

7.3.2 Using External Amplitude Control

When External Amplitude Control is enabled, the front panel amplitude control is disabled and the LCD displays four dashes (see [Figure 7.3 LCD when in External Amplitude Control Mode](#) below).

Figure 7.3 LCD when in External Amplitude Control Mode

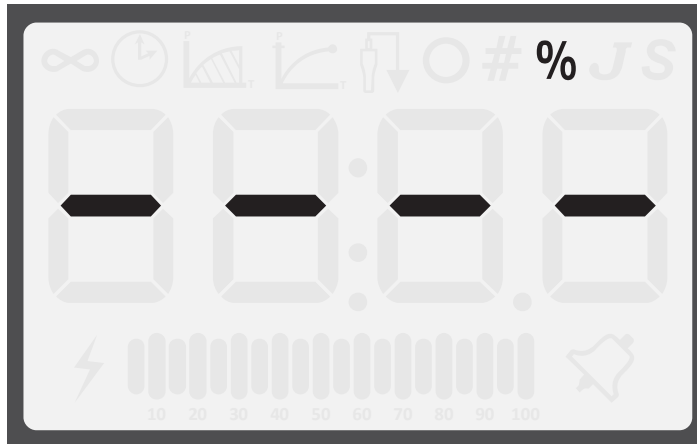

The ultrasonic amplitude can be controlled using one of the two analog input pins on the user I/O connector (pins 17 and 18) or through the Ether/Net IP interface.

7.3.3 Using the Web Page Interface

The ultrasonic amplitude can be set to a user specified value using the web page interface. For more information, refer to the DCX A/F Series Web Page Instruction Manual.

7.4 Resetting the Power Supply Alarms

You need to reset the weld system when you get an overload. When there is an overload, the alarm icon appears on the front panel LCD and the General Alarm output on the user I/O connector becomes active. The procedure for resetting the power supply depends on the power supply alarm settings. Refer to [Table 7.24 Resetting the DCX F-EIP Power Supply](#) for reset procedures.

Table 7.24 Resetting the DCX F-EIP Power Supply

Alarm Setting	Reset Procedure
Reset Required	Press the front panel Reset key. You can also send an External Reset signal.
No Reset Required	Remove and re-apply the start signal.

For more information on interfacing the DCX F-EIP Power Supply using the user I/O connections refer to [5.4.1 User I/O Connections](#) in [Chapter 5: Installation and Setup](#).

7.5 Configuring the Power Supply Registers

At power up the DCX F-EIP Power Supply will display the last amplitude setting, this is indicated by the percentage icon (%) on the LCD. Refer to [Figure 7.2 LCD at Power Up](#).

Table 7.25 Steps to Configure the Power Supply Registers





Step	Action	Reference
1	<p>Press the Configuration key until the number icon (#) appears on the LCD.</p> <p>The power supply will display register 101 at every power up.</p>	 <p>The LCD display shows the number '101' in the center. Above the numbers, the '#' icon is highlighted. The bottom panel shows a hand pressing the Configuration key (the key with a red circle and a lightning bolt).</p>
2	<p>Press and release the Up or Down arrow keys to select the desired register. For a detailed description of available registers refer to Table 7.26 Power Supply Registers.</p>	 <p>The LCD display shows the number '108' in the center. The Up arrow key on the bottom panel is highlighted with a hand.</p>
3	<p>Once you have reached the desired register, press the Configuration key. The register value will be displayed, this is indicated by the circle icon.</p>	 <p>The LCD display shows the number '80' in the center. Above the numbers, the circle icon is highlighted. The bottom panel shows a hand pressing the Configuration key.</p>

Table 7.25 Steps to Configure the Power Supply Registers

Step	Action	Reference
4	<p>Press and release the Up or Down arrow keys to enter the desired value at 1 increments.</p> <p>Press and hold down the Up and Down arrow keys and the value will auto increment at 1 increments every quarter of a second.</p> <p>After holding down an arrow key for four straight seconds, the value will auto increment at 5 increments every quarter of a second.</p> <p>Or press the Reset key to enter the default value. For detailed default values of available registers refer to Table 7.26 Power Supply Registers.</p>	
5	<p>Press the Configuration key to save the value. The current amplitude setting will be displayed only for continuous mode. For all the other modes, it will display the primary parameter of that mode.</p>	

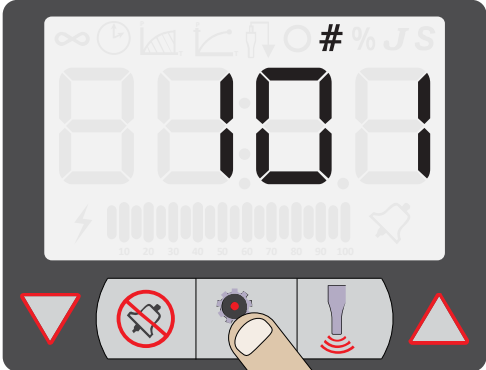
7.5.1 Power Supply Registers

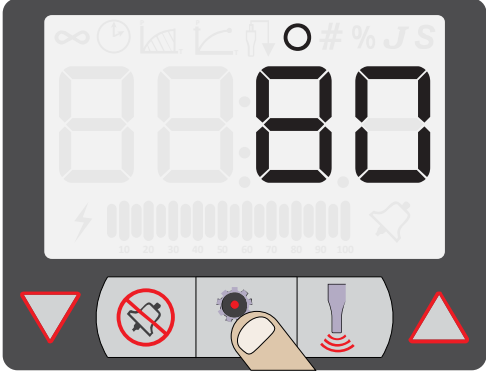
Table 7.26 Power Supply Registers

Register	Description	Default Value	Max. Value	Min. Value
101	Software version	N/A	N/A	N/A
102	Bar graph identification after weld complete 0=Power 1=Frequency	0	1	0
104	External amplitude control - user analog input or fieldbus 0=Off 1=On	0	1	0
105	Start ramp time (ms)	80	1000	10
106	Store frequency at end of weld 0=Off 1=On	1	1	0
107	Power up seek/scan 0=Off 1=Seek, 2=Scan	1	2	0
108	Seek ramp time (ms)	80	1000	10
109	Timed seek (every 60 seconds) 0=Off 1=On	0	1	0
110	Seek time (ms)	500	1000	10
111	External Frequency Offset 0=Off 1=On	0	1	0
112	Frequency Offset Value	0		
113	Cutoffs 0=Off 1=On	0	1	0
114	Limits 0=Off 1=On	0	1	0

Table 7.26 Power Supply Registers

Register	Description	Default Value	Max. Value	Min. Value
115	Restore Defaults 0=Off 1=Just weld preset 2=System defaults	0	2	0
116	IP Address - 1	192	255	0
117	IP Address - 2	168	255	0
118	IP Address - 3	10	255	0
119	IP Address - 4	100	255	0
120	Gateway for IP Address - 1	192	255	0
121	Gateway for IP Address - 2	168	255	0
122	Gateway for IP Address - 3	10	255	0
123	Gateway for IP Address - 4	1	255	0
124	Subnet Mask for IP Address - 1	255	255	0
125	Subnet Mask for IP Address - 2	255	255	0
126	Subnet Mask for IP Address - 3	255	255	0
127	Subnet Mask for IP Address - 4	0	255	0
128	DHCP Settings 0=Server 1=Client 2=Static 3=Restore Registers 116-128 to default	2	3	0
134	Backlight Timeout (s) 0=Always on	600	9999	0
135	Auto scroll step size	5	50	1
136	Power on display 0=Weld Mode 1=Amplitude	1	1	0
138	Weld Mode 0=Continous 1=Time 2=Energy 3=Peak Power 4=Ground Detect	0	4	0
139	MAC Address 1	N/A	FFFF	0

Table 7.26 Power Supply Registers

Register	Description	Default Value	Max. Value	Min. Value
140	MAC Address 2	N/A	FFFF	0
141	MAC Address 3	N/A	FFFF	0
142	Ethernet IP Address - 1	192	255	0
143	Ethernet IP Address - 2	168	255	0
144	Ethernet IP Address - 3	10	255	0
145	Ethernet IP Address - 4	101	255	0
146	Gateway for Ethernet IP Address - 1	192	255	0
147	Gateway for Ethernet IP Address - 2	198	255	0
148	Gateway for Ethernet IP Address - 3	10	255	0
149	Gateway for Ethernet IP Address - 4	1	255	0
150	Subnet Mask for Ethernet IP Address - 1	255	255	0
151	Subnet Mask for Ethernet IP Address - 2	255	255	0
152	Subnet Mask for Ethernet IP Address - 3	255	255	0
153	Subnet Mask for Ethernet IP Address - 4	0	255	0
154	Restore registers 142–154 to default.	0	1	0
158	+Time Limit 0: Select to disable limit 0.010-30.00s: Set -Time Limit	0	30.00s	0.010s
159	-Time Limit 0: Select to disable limit 0.010-30.00s: Set +Time Limit	0	30.00s	0.010s
160	+Energy Limit 0: Select to disable limit 0.1-9999J: Set -Energy Limit	0	9999J	0.1J
161	-Energy Limit 0: Select to disable limit 0.1-9999J: Set +Energy Limit	0	9999J	0.1J
162	+Power Limit 0: Select to disable limit 1-100%: Set -Power Limit	0	100%	1%
163	-Power Limit 0: Select to disable limit 1-100%: Set +Power Limit	0	100%	1%

7.6 Save/Recall Presets

If you wish to save your current weld cycle settings for later use, you can save it into a preset location. 32 preset locations are available. Preset settings are saved until they are over-written, and are maintained in memory even if the system is turned off or unplugged.

7.6.1 Save Preset

Table 7.27 Save Preset



Step	Action	Reference
1	Set the desired weld mode and parameters. See 7.1 Setting Primary Parameters for more information.	
2	Press the Configuration key until the preset location screen (Pr:XX) appears on the LCD.	
3	Press the Up or Down arrow keys to select the desired preset location to use. Once you have reached the desired preset location, press the Configuration key to select it. You will be returned to the main screen.	

Table 7.27 Save Preset

Step	Action	Reference
4	<p>While on the main screen, press and hold the Reset key. While holding down the Reset key, press the Configuration to save your current control mode and parameters into the selected preset location (Pr:XX).</p> <p>The LCD will blink twice to confirm that the preset was saved correctly.</p>	 <p>The image shows the LCD display with the number '100' in the center. Above the display are various icons including an infinity symbol, a clock, a fan, a left arrow, a right arrow, a circle with a dot, a hash symbol, and a percentage sign. Below the display is a battery level indicator and a star icon. At the bottom of the screen are four touch-sensitive buttons: a left-pointing red triangle, a button with a crossed-out reset icon, a button with a gear icon (Configuration), and a right-pointing red triangle. A hand is shown pressing the Configuration button.</p>

7.6.2 Recall Preset

Table 7.28 Recall Preset

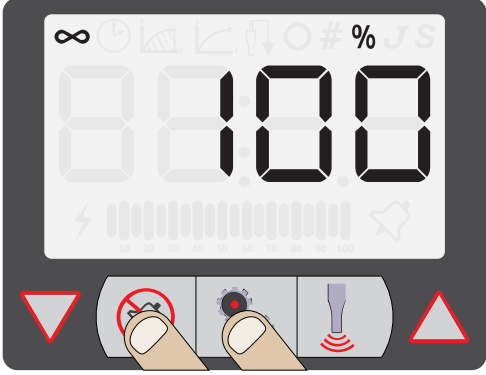

Step	Action	Reference
1	<p>Press the Configuration key until the preset location screen (Pr:XX) appears on the LCD.</p>	 <p>The image shows the LCD display with 'Pr:00' in the center. The icons and layout are the same as in the previous image. A hand is shown pressing the Configuration button.</p>
2	<p>Press the Up or Down arrow keys to select the desired preset location to recall.</p> <p>Once you have reached the desired preset location, press and hold the Reset key. While holding down the Reset key, press the Configuration for 3 seconds to recall the selected preset location (Pr:XX).</p> <p>The LCD will blink twice to confirm that the preset was recalled correctly.</p>	 <p>The image shows the LCD display with 'Pr:05' in the center. The icons and layout are the same as in the previous images. A hand is shown pressing the Configuration button.</p>

Table 7.28 Recall Preset

Step	Action	Reference
3	You will be returned to the main screen with the recalled preset location settings.	 <p>The image shows a digital display screen with a black background. At the top, there is a row of small icons: an infinity symbol, a clock, a fan, a left arrow, a right arrow, a circle with a dot, a hash symbol, and a percent sign. Below these icons, the number '100' is displayed in large, white, seven-segment digits. Underneath the number is a battery level indicator consisting of a lightning bolt icon followed by a series of vertical bars of varying heights. At the bottom of the screen, there is a row of four larger icons: a red downward-pointing triangle, a red circle with a diagonal slash over a fan icon, a gear icon, and a red upward-pointing triangle. To the right of the gear icon is a speaker icon with sound waves.</p>

7.7 LCD Bar-Graph

While ultrasonic power is active the LCD will always display the power value on the 20-segment LCD bar-graph as a percentage of the maximum output power.

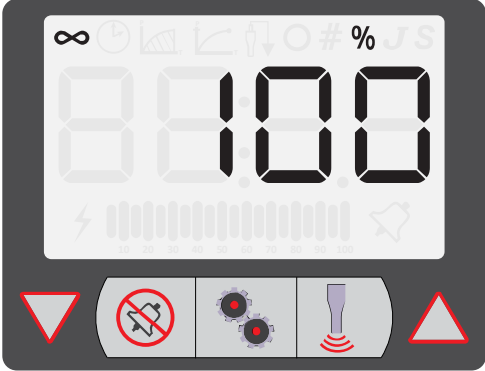
At the end of a weld or test cycle, the bar-graph is factory set to represent the cycle's peak power as a percentage of the maximum output power.

The power supply can also be configured to show a single bar on the LCD bar-graph to represent the stack operating frequency stored at the end of each weld or test cycle. This option can be used to troubleshoot operating frequency changes as a result of heating effects, coupling, tooling wear, etc.

For information on how to set the power supply registers see [7.5 Configuring the Power Supply Registers](#).

7.7.1 Power Bar-Graph Interpretation

The lightning bolt left of the bar-graph indicates ultrasonic power is running. Each of the segments represent 5% increments of the maximum output power. The segments will only appear if the output power has exceeded the value represented. For example if the power is 4% only the lightning bolt will be on. When it reaches 5% the first bar-graph segment will appear.

Table 7.29 Power Bar-Graph Interpretation Examples

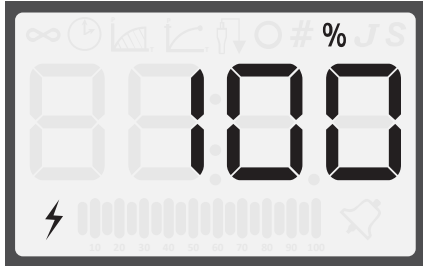
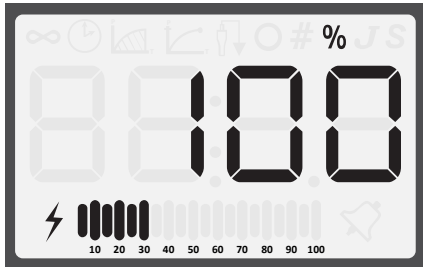
Description	Reference
<p>In this example only the lightning bolt appears left of the bar-graph. This means power is between 0% and less than 5%. If the power supply is 800 W the actual output power is between 0 W and less than 40 W.</p>	 <p>The LCD display shows a digital readout of '100' followed by a '%' sign. To the left of the bar-graph area, a lightning bolt icon is illuminated. The bar-graph itself consists of 20 vertical segments, all of which are currently unlit.</p>
<p>In this example the first six segments appear on the bar-graph. This means power is between 30% and less than 35%. If the power supply is 800 W, the actual output power is between 240 W and less than 280 W.</p>	 <p>The LCD display shows a digital readout of '100' followed by a '%' sign. To the left of the bar-graph area, a lightning bolt icon is illuminated. The bar-graph consists of 20 vertical segments, with the first six segments from the left being lit, and the remaining 14 segments being unlit. Below the bar-graph, numerical labels '10 20 30 40 50 60 70 80 90 100' are visible.</p>

7.7.2 Frequency Bar-Graph Interpretation

The actual frequency depends on the power supply's operating frequency. Use [Table 7.30](#) to [Table 7.32](#) below to interpret frequency bar-graph readings.

NOTICE	
	<p>If there is a test overload or an external memory reset signal is received, then the 50% segment will be displayed and blinking.</p>

Table 7.30 Frequency Bar-Graph Interpretation - 20 kHz (50 Hz Segment)

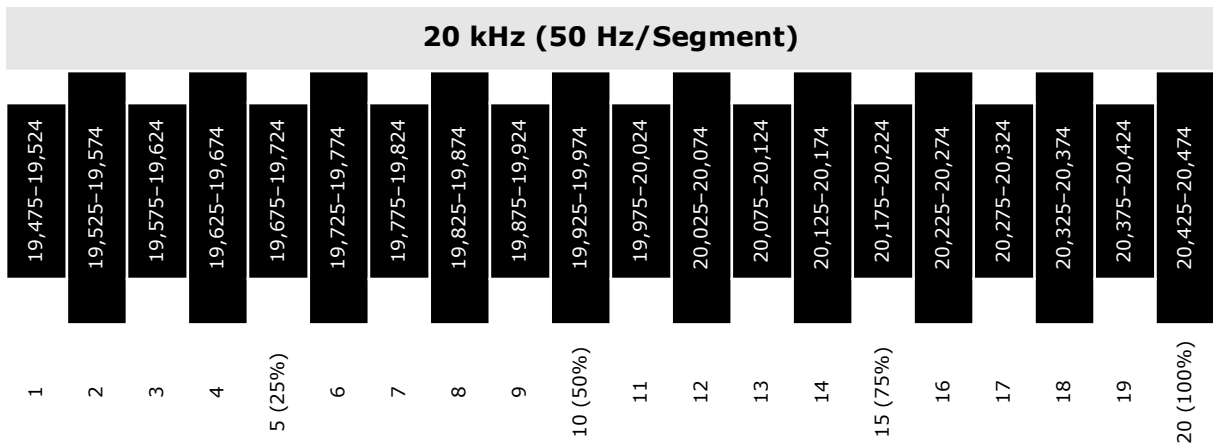

Table 7.31 Frequency Bar-Graph Interpretation - 30 kHz (76 Hz Segment)

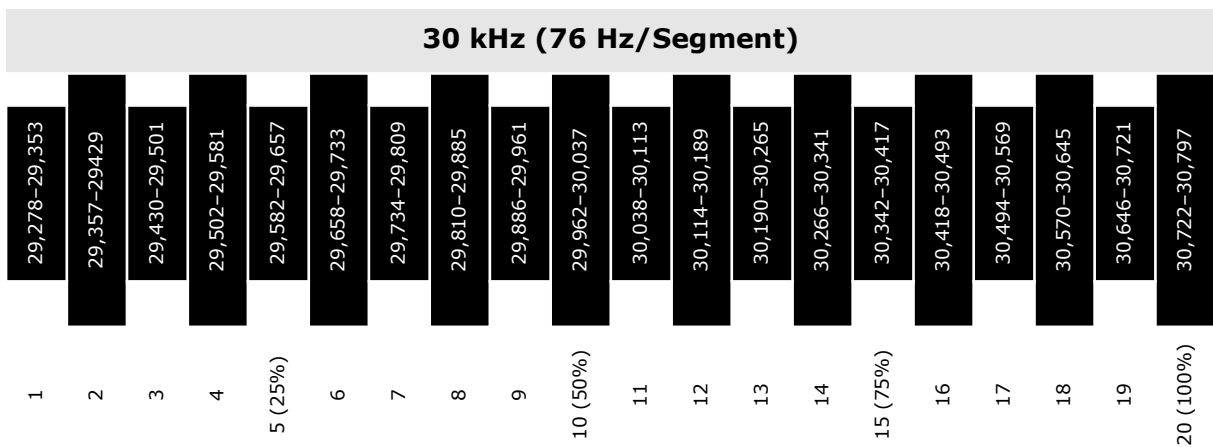

Table 7.32 Frequency Bar-Graph Interpretation - 40 kHz (100 Hz/Segment)

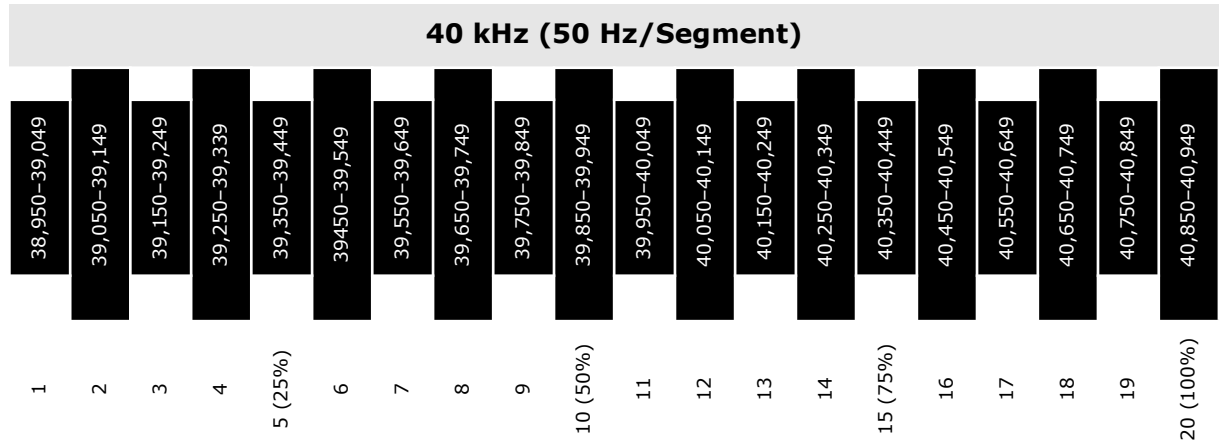



Table 7.33 Frequency Bar-Graph Interpretation Examples

Description	Reference
<p>In this example the bar is located in the 11th segment. If the power supply is a 20 kHz unit, the stack is running in the frequency range of 19,975 Hz to 20,024 Hz.</p>	
<p>In this example the bar is located in the 7th segment. If the power supply is a 20 kHz unit, the stack is running in the frequency range of 19,775 Hz to 19,824 Hz.</p>	

7.8 Ultrasonics Test Procedure

The Ultrasonics Test function measures ultrasonic power dissipated by the ultrasonic stack with no load. The ultrasonics test procedure involves an automatic matching of the frequency of the power supply to the frequency of the converter-booster-horn stack.

WARNING	High Voltage Hazard
	<p>Ensure that no one is in contact with the horn when testing the power supply.</p> <p>Do not cycle the welding system if either the RF cable or converter is disconnected.</p>

WARNING	High Voltage Hazard
	<p>Ensure the power supply is properly connected, as indicated in 5.3 Installation Steps.</p>

7.8.1 Using the Front Panel Controls



NOTICE	
	<p>To use the front panel controls, the DCX F-EIP Power Supply unit must be in manual mode.</p>

Table 7.34 Power Supply Ultrasonic Test Procedure (Front Panel)

Step	Action	Reference
1	<p>Press the test key for 1-2 seconds, then release. The Sonics Active indicator appears while the test key is pressed. If the power supply alarm indicator does not appear, the test procedure is finished.</p>	
2	<p>If the alarm indicator appears, press the alarm reset key and repeat step 2 one time only. If the alarm persists, refer to 9.5 Troubleshooting. See Appendix A: Alarms for additional information.</p>	

7.9 Using the I/O Connections

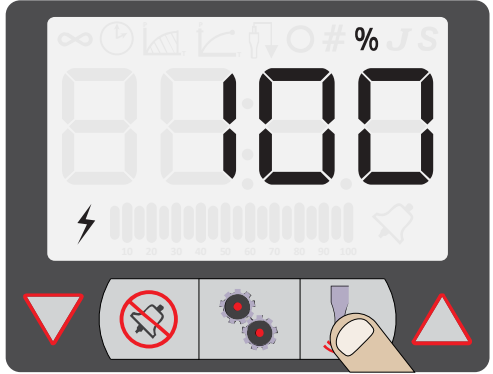
Table 7.35 Power Supply Ultrasonic Test Procedure (User I/O)

Step	Action	Reference
1	Wire the necessary I/O signals as shown on Figure 7.4 Test Connections , or using a similar setup.	Refer to Figure 7.4 Test Connections below.
2	Send an External Test signal for 1-2 seconds. The Sonics Active output will become active and the Sonics Active indicator appears while the External Start Signal is present. If the General Alarm output/ alarm indicator does not become active, the test procedure is finished. NOTICE Power supply must be in manual mode.	
3	If the General Alarm output/alarm indicator becomes active, send an External Reset signal and repeat step 2 one time only. If the alarm persists, refer to 9.5 Troubleshooting .	

Figure 7.4 Test Connections



Chapter 8: EtherNet/IP Operation

8.1	EtherNet/IP	140
8.2	EtherNet/IP Overview	143
8.3	Message Type Definitions.....	144
8.4	Communication to the CompactLogix Via EtherNet/IP	145
8.5	Implicit Messaging	149
8.6	Explicit Messaging	161
8.7	Implicit Messaging - Control/Status Word	168
8.8	Implicit Messaging Live Channel	178

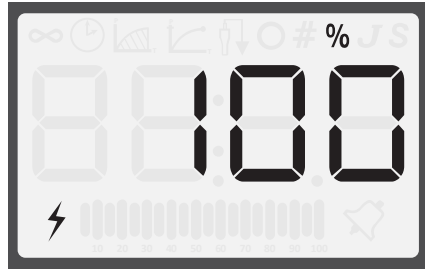
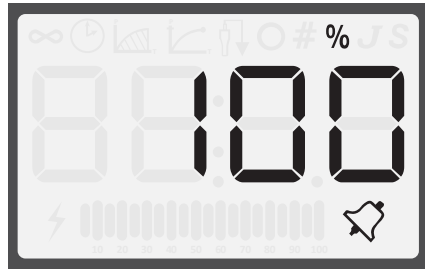
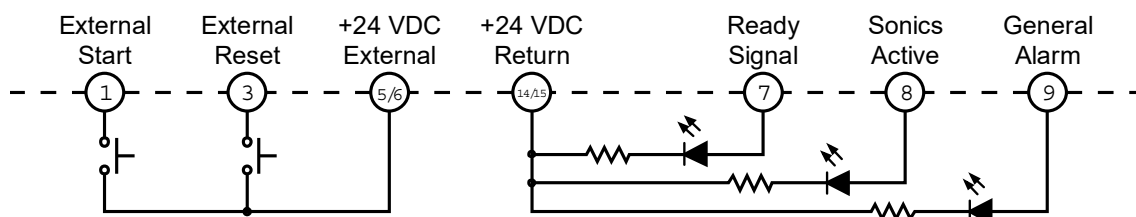
8.1 EtherNet/IP

The DCX F-EIP Power Supply is controlled via a EtherNet/IP interface. The parameters of the DCX F-EIP Power Supply, for example, are also configured via EtherNet/IP.

The number of EtherNet/IP slaves to be set up is limited to max. 125 stations, due to the standardized interface layout.

8.1.1 LED Status Indicator

To get a fast overview about the status of the DCX F-EIP Power Supply, three LEDs are placed on the front of the unit. The subsequent table describes the meaning of the LEDs.

Figure 8.1 LED Status Indicator

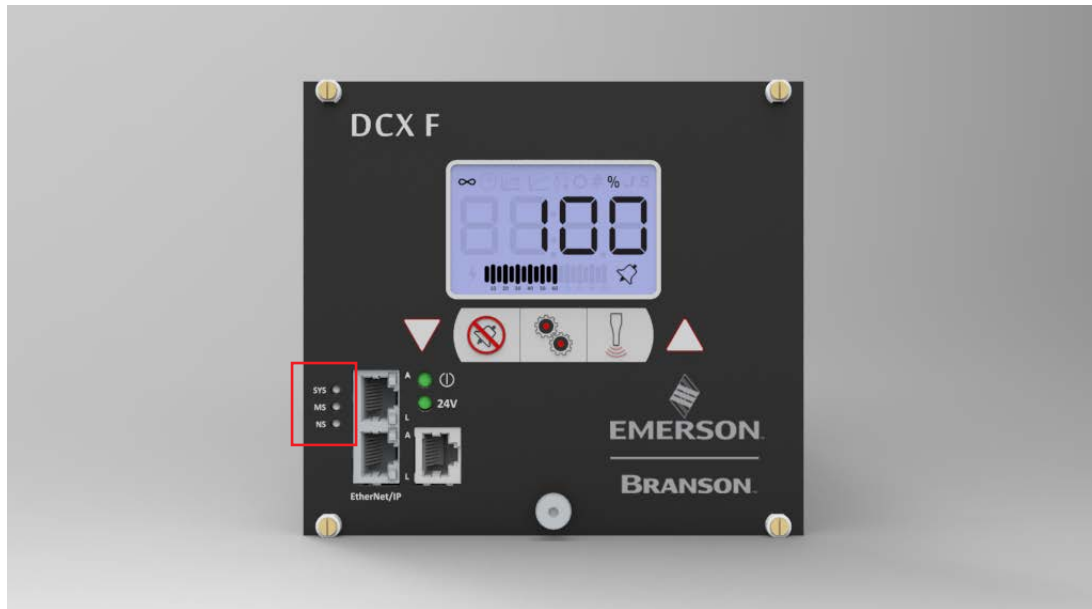

Table 8.1 DCX F-EIP Power Supply LED Status Indicator

LED	Color	State	Description
SYS	Green	On	Operating System running.
	Green/ Yellow	Blinking green/yellow	Bootloader is waiting for firmware.
	Yellow	Static	Bootloader is waiting for software.
	-	Off	Power supply for the device is missing or hardware defect.

Table 8.1 DCX F-EIP Power Supply LED Status Indicator

LED	Color	State	Description
MS	Green	On	Device operational: If the device is operating correctly, the module status indicator will be steady green.
	Green	Flashing	Standby: If the device has not been configured, the module status indicator will be flashing green.
	Red	On	Major fault: If the device has detected a non-recoverable major fault, the module status indicator will be steady red.
	Red	Flashing	Minor fault: If the device has detected a recoverable minor fault, the module status indicator will be flashing red. An incorrect or inconsistent configuration would be considered a minor fault.
	Green/Red	Flashing	Self-test: While the device is performing its power up testing, the module status indicator will be flashing green/red.
	-	Off	No power: If no power is supplied to the device, the module status indicator will be steady off.
NS	Green	On	Connected: If the device has at least one established connection, the network status indicator will be steady green.
	Green	Flashing	No connection: If the device has no established connections, but has obtained an IP address, the network status indicator will be flashing green.
	Red	On	Duplicate IP: If the device has detected that its IP address is already in use, the network status indicator will be steady red.
	Red	Flashing	Connection timeout: If one or more of the connections in which this device is the target has timed out, the network status indicator will be flashing red.
	Green/Red	Flashing	Self-test: While the device is performing its power up testing, the network status indicator will be flashing green/red.
	-	Off	Not powered, no IP address: If the device does not have an IP address or is powered off, the network status indicator will be off.

8.1.2 EtherNet/IP Specifications

The EtherNet/IP interface has the following technical specifications:

- Maximum number of input data: 504 bytes
- Maximum number of output data: 504 bytes
- IO Connection: 1 explicit owner, up to 2 listen only
- IO Connection type: Cyclic, minimum 1 ms
- Maximum number of connections: 8, explicit and implicit connections
- UCMM (Unconnected Message Manager): Supported
- Explicit Messages: Get_Attribute, Set_Attribute
- Predefined standard objects: Identity Object, Message Route Object, Assembly Object, Connection Manager, Ethernet Link Object, TCP/P Object, DLR Object
- Maximum number of user specific objects: 20
- DHCP: Supported
- BOOTP: Supported
- Baud Rates: 10 and 100 MBit/Sec
- Data transport layer: Ethernet II, IEEE802.3
- ACD (Address conflict detection): Supported
- DLR (Device level ring) (Ring topology): Supported
- Integrated switch: Supported

8.2 EtherNet/IP Overview

NOTICE	
	<p>This section assumes that the user has a fundamental understanding of the various Rockwell PLC platforms and Rockwell software packages. It is not intended to be an instructional manual for the above items.</p> <p>Because of the variety of uses for the products described in this publication, those responsible for the application and use of this equipment must satisfy themselves that all necessary steps have been taken to assure that each application and use meets all performance and safety requirements, including any applicable laws, regulations, codes and standards. The illustrations, charts, sample programs and layout examples shown in this section are intended solely for purposes of example. Since there are many variables and requirements associated with any particular installation, Branson does not assume responsibility or liability for actual use based upon the examples shown in this publication.</p>

8.2.1 Industrial Ethernet Protocol

The Industrial Ethernet Protocol (EtherNet/IP) was originally developed by Rockwell Automation and is now managed by the Open DeviceNet Vendors Association (ODVA). It is a well-established Industrial Ethernet communication system with Real-Time capabilities. EtherNet/IP has a strong presence in America and Asia and has been selected by many major manufacturers as a plant wide communication system for factories worldwide. EtherNet/IP is standardized in the International standard IEC 61158 and EtherNet/IP devices are certified by ODVA for interoperability and conformance.

EtherNet IP extends commercial off-the-shelf Ethernet to the Common Industrial Protocol (CIP) — the same upper-layer protocol and object model found in DeviceNet and ControlNet. CIP allows EtherNet/IP and DeviceNet system integrators and users to apply the same objects and profiles for plug-and-play interoperability among devices from multiple vendors and in multiple sub-nets. Combined, DeviceNet, ControlNet and EtherNet/IP promote transparency from sensors to the enterprise software.

8.2.2 Common Industrial Protocol (CIP)

CIP provides a wide range of standard objects and services for access to data and for control of network devices via so called “implicit” and “explicit” messages. The CIP data packets are encapsulated before they will be send with standard TCP or UDP telegrams on the Ethernet.

EtherNet/IP uses all the transport and control protocols of standard Ethernet including the Transport Control Protocol (TCP), the User Datagram Protocol (UDP), the Internet Protocol (IP) and the media access and signaling technologies found in off-the-shelf Ethernet technology. Building on these standard communication technologies means that EtherNet/IP works transparently with all the standard Ethernet devices found in today's market place. It also means that EtherNet/IP automatically benefits from all further technology enhancements such as Gigabit Ethernet and Wireless technologies.

8.3 Message Type Definitions

8.3.1 Explicit Message

Explicit messages contain addressing and service information that directs the receiving device to perform a certain service (action) on a specific part (e.g., an attribute) of a device. Explicit message data can be sent or received from any available instance in the EtherNet/IP device being communicated to. Explicit messages allow for easy management of different data types.

8.3.2 Implicit (I/O) Message

Implicit messages do not carry address and/or service information; the consuming node(s) already know what to do with the data based on the connection ID that was assigned when the connection was established. Implicit messages are so named because the meaning of the data is implied by the connection ID. When an Implicit message procedure is setup for a specific device. All data sent to or received from the device must be of the same type.

8.4 Communication to the CompactLogix Via EtherNet/IP

The purpose of this section is to describe the configuration steps necessary to establish a communication path between the DCX F-EIP Power Supply and a CompactLogix unit. For this example, you will need a 1769-L32E together with a CompactLogix Controller. You will also need Rockwell Software's RSLinx and RSLogix 5000 software configuration utilities.

NOTICE



The network parameters used in this example will almost certainly not apply to your application. Be sure to consult your network administrator when selecting appropriate values.

8.4.1 Generic Module Configuration

1. Run the RSLogix 5000 program and create a New File.

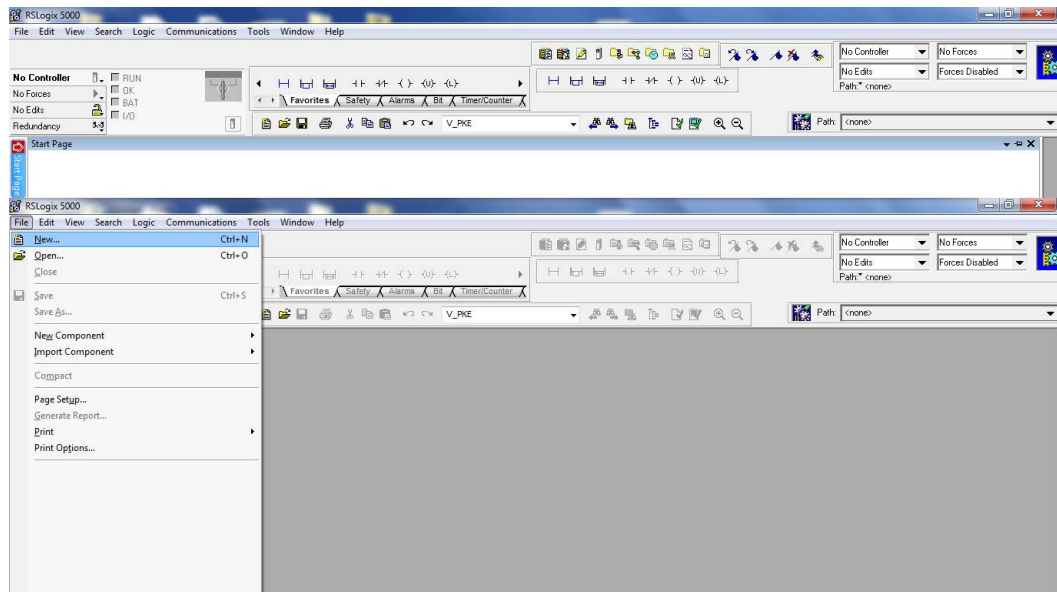

2. On the New Controller dialog box, select the Type of the controller 1769-L32E and enter a Name to identify the controller. The controller will be added to the I/O Configuration node in the Controller Organizer view.

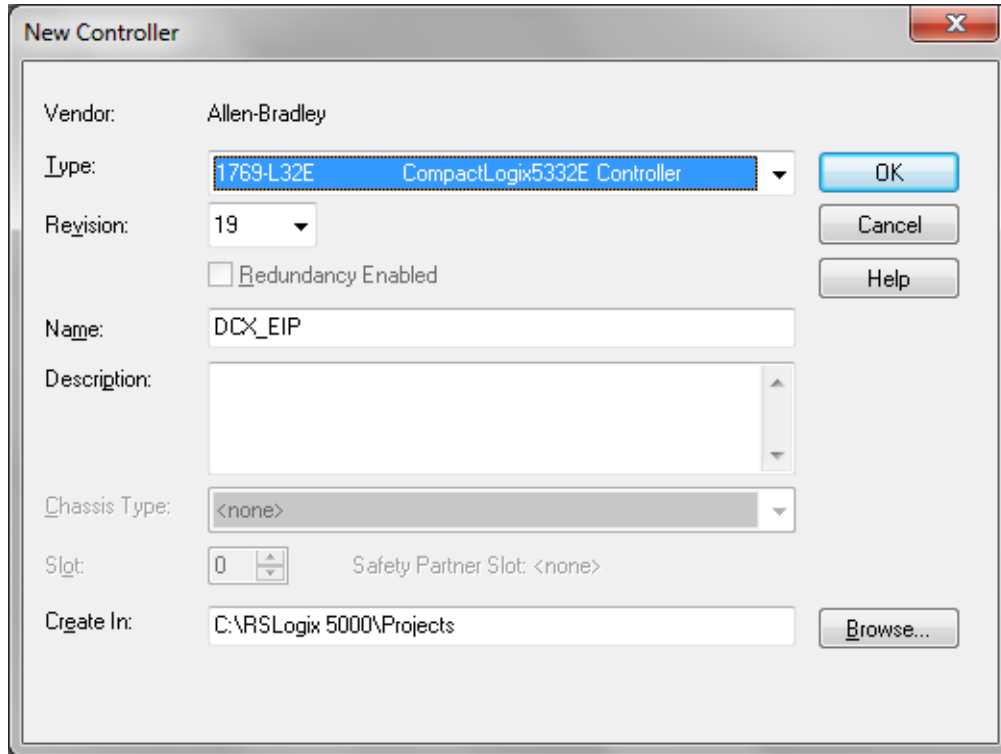

3. Right click on the 1769-L32E node in the Controller Organizer view and choose Add Module.

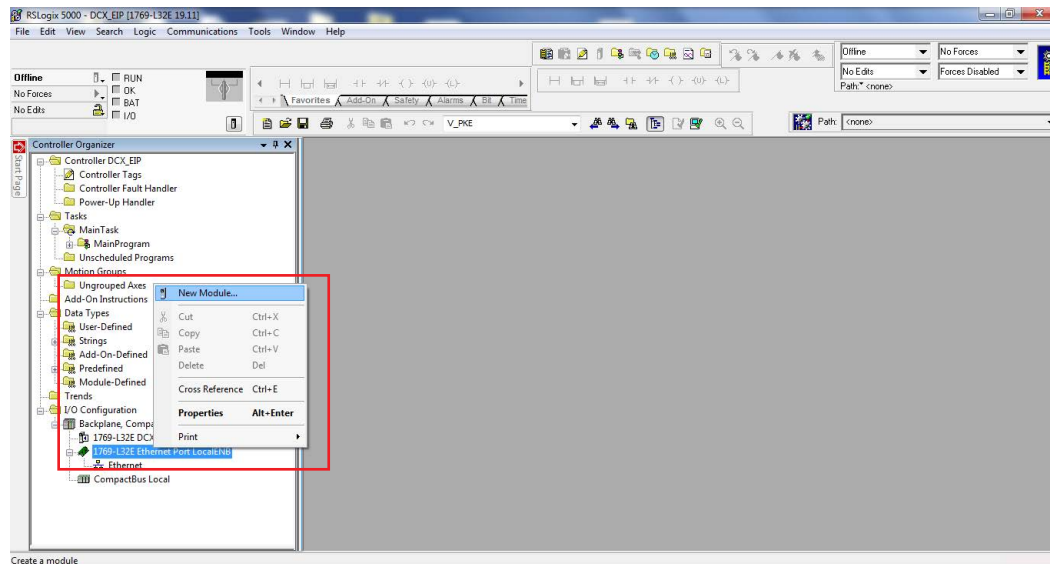

- On the Select Module dialog box, select the ETHERNET-MODULE Generic Ethernet Module and click OK.

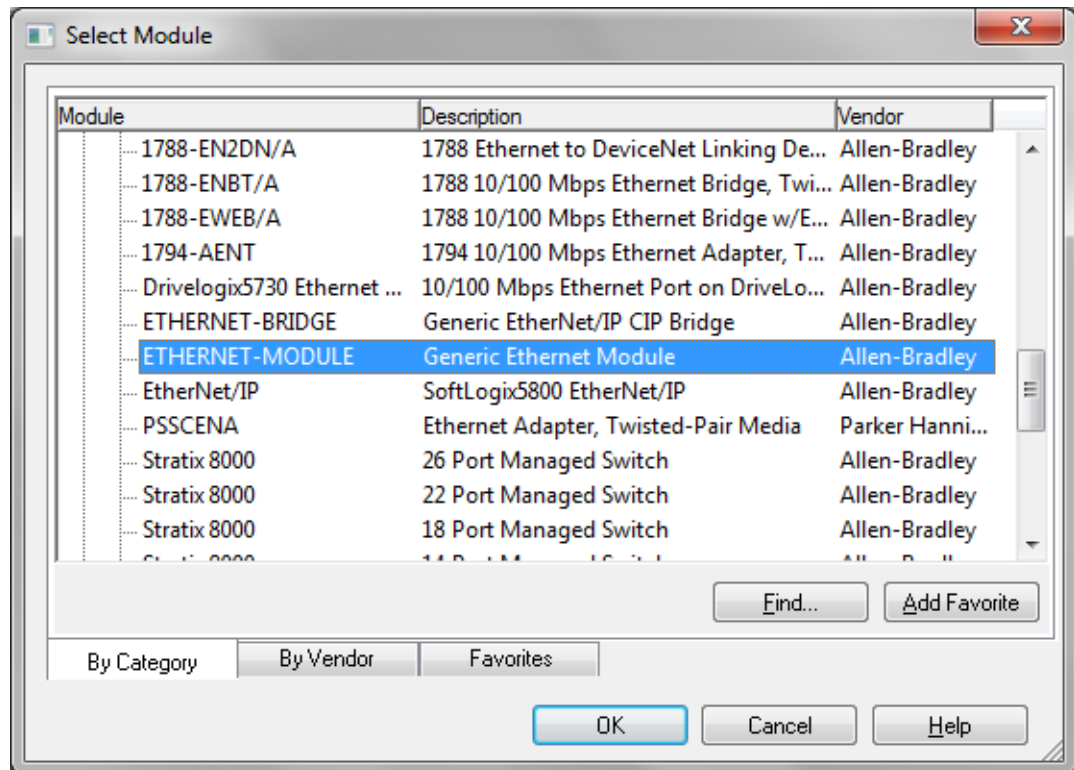

- This will open the Module Properties dialog box.

New Module

Type: ETHERNET-MODULE Generic Ethernet Module
 Vendor: Allen-Bradley
 Parent: LocalENB
 Name:
 Description:
 Comm Format: Data - INT
 Address / Host Name
 IP Address:
 IP Address:

Connection Parameters

Input:	Assembly Instance: <input type="text" value="101"/>	Size: <input type="text" value="20"/> (16-bit)
Output:	Assembly Instance: <input type="text" value="100"/>	Size: <input type="text" value="20"/> (16-bit)
Configuration:	Assembly Instance: <input type="text" value="102"/>	Size: <input type="text" value="0"/> (8-bit)
Status Input:	<input type="text"/>	
Status Output:	<input type="text"/>	

Open Module Properties

OK Cancel Help

- In the Name, enter a descriptive name to identify the module
- Select Data - INT on the Comm Format menu
- In the Address/Host Name, enter the IP Address of the DCX F-EIP Power Supply unit

- Enter 101 in the Input Assembly Connection Point and a size of 20. This will match a read only Slave Gateway block configured in the DCX F-EIP Power Supply, and will be used for reading data from the DCX F-EIP Power Supply to the CompactLogix
- Enter 100 in the Output Assembly Connection Point and a size of 20. This will match a read/write Slave Gateway block configured in the DCX F-EIP Power Supply, and will be used for writing data from the CompactLogix to the DCX F-EIP Power Supply
- Enter 102 in the Configuration Connection Point and a size of 0
- Press Finish to add the DCX F-EIP Power Supply to the I/O configuration

8.5 Implicit Messaging

8.5.1 I/O Setup for EtherNet/IP Module With Standard Configuration

Figure 8.2 I/O Setup for EtherNet/IP Module With Standard Configuration

The screenshot shows the 'New Module' configuration window. The 'Type' is 'ETHERNET-MODULE Generic Ethernet Module', 'Vendor' is 'Allen-Bradley', and 'Parent' is 'LocalENB'. The 'Name' is 'DCX_EIP'. The 'Description' field is empty. The 'Comm Format' is set to 'Data - INT'. Under 'Address / Host Name', the 'IP Address' is '192 . 168 . 10 . 50'. The 'Connection Parameters' section has 'Input' (101, 20, 16-bit), 'Output' (100, 20, 16-bit), and 'Configuration' (102, 0, 8-bit). There are also fields for 'Status Input' and 'Status Output'. At the bottom, there is an 'Open Module Properties' checkbox and 'OK', 'Cancel', and 'Help' buttons.

8.5.2 DCX Inputs/PLC Outputs (20 words)

Table 8.2 DCX Inputs/PLC Outputs (20 words)

Data	Description	Data Type	Access	Unit	Notes
0	STW1 (STW Word 1)	UINT16	W	-	See Table 8.3 and Table 8.6
1	SWT2 (STW Word 2)			-	
2	External Amplitude			%	
3	Frequency Offset			Hz	
4-19	Reserved				

8.5.2.1 Control Word (STW1)

Table 8.3 Control Word (STW1)

	Bit	Name	Description	Notes
	0	RES	Reserved	Not used
	1	ES	Emergency Stop	1=Emergency Stop
	2	RES	Reserved	Not used
	3	RES	Reserved	Not used
	4	HFS0	Stack Preset Number 0	See Table 8.4 HFS Bit (Control Word) .
	5	HFS1	Stack Preset Number 1	
	6	HFS2	Stack Preset Number 2	
	7	HFS3	Stack Preset Number 3	
	<p>NOTICE</p> <p>HFS stack presets numbers are feedback inputs to indicate RF relay switching state. This is used only in stack sequencing applications. Set HFS to 0 if not using stack sequencing.</p>			
STW1	8	PSN0	Weld Preset Number 0	See Table 8.5 PSN Bit (Control Word) .
	9	PSN1	Weld Preset Number 1	
	10	PSN2	Weld Preset Number 2	
	11	PSN3	Weld Preset Number 3	
	12	PSN4	Weld Preset Number 4	
	<p>NOTICE</p> <p>Preset 0 is reserved for the running preset. When a preset number is recalled, it is copied to Preset 0 and becomes the running preset.</p>			
	13	RES	Reserved	Not used
	14	MA	Manual/Auto	Set and leave to 1 for implicit messaging control Set to 0 for discrete I/O control
	15	RES	Reserved	Not used

HFS Bit (Control Word)

Table 8.4 HFS Bit (Control Word)

HFS3	HFS2	HFS1	HFS0	Stack Selected
0	0	0	0	No stack change
0	0	0	1	1 (factory default)
0	0	1	0	2
0	0	1	1	3
0	1	0	0	4
0	1	0	1	5
0	1	1	0	6
0	1	1	1	7
1	0	0	0	8
1	0	0	1	9
1	0	1	0	10
1	0	1	1	11
1	1	0	0	12
1	1	0	1	13
1	1	1	0	14
1	1	1	1	15

PSN Bit (Control Word)

Table 8.5 PSN Bit (Control Word)

PSN4	PSN3	PSN2	PSN1	PSN0	Preset Selected
0	0	0	0	0	Previous preset
0	0	0	0	1	1
0	0	0	1	0	2
0	0	0	1	1	3
0	0	1	0	0	4
0	0	1	0	1	5
0	0	1	1	0	6
0	0	1	1	1	7
0	1	0	0	0	8
0	1	0	0	1	9

Table 8.5 PSN Bit (Control Word)

PSN4	PSN3	PSN2	PSN1	PSN0	Preset Selected
0	1	0	1	0	10
0	1	0	1	1	11
0	1	1	0	0	12
0	1	1	0	1	13
0	1	1	1	0	14
0	1	1	1	1	15
1	0	0	0	0	16
1	0	0	0	1	17
1	0	0	1	0	18
1	0	0	1	1	19
1	0	1	0	0	20
1	0	1	0	1	21
1	0	1	1	0	22
1	0	1	1	1	23
1	1	0	0	0	24
1	1	0	0	1	25
1	1	0	1	0	26
1	1	0	1	1	27
1	1	1	0	0	28
1	1	1	0	1	29
1	1	1	1	0	30
1	1	1	1	1	31

8.5.2.2 Control Word (STW2)

Table 8.6 Control Word (STW2)

	Bit	Name	Description	Notes
STW2	0	FCT	Weld Function	1 = To run ultrasonics in normal mode
	1	SFCT	Stack Function	See Table 8.7
	2	SFCT0	Stack Function 0	
	3	SFCT1	Stack Function 1	
	4	SFCT2	Stack Function 2	
	5	RES	Reserved	Not used
	6	MCLR	Memory Clear	1 = Memory offset will be set to 0
	7	RES	Reserved	Not used
	8	RST	Reset	1 = Reset
	9	ON	Run Ultrasonics	1 = Will turn on ultrasonics based on combination of SFCT or FCT bits. See bits 0 - 4. NOTICE Signal must be held for 10ms minimum
	10	RES	Reserved	Not used
	11	RES	Reserved	
	12	GNDDT	Ground Detect	1 = Ground has been detected
	13	APROF	Amplitude Profile	1 = Switch from amplitude 1 to amplitude 2
	14	RES	Reserved	Not used
15	RES	Reserved		

8.5.2.3 Stack Function

Table 8.7 Stack Function

Bit	Name	Test	Scan	Seek
STW2/1	SFCT	1	1	1
STW2/2	SFCT0	1	0	0
STW2/3	SFCT1	0	1	0
STW2/4	SFCT2	0	0	0

8.5.3 Implicit Message for Reset

Table 8.8 Implicit Message for Reset

Value	STW1 Bit															
	15	14	13	12	11	10	9	8	7	6	5	4	3	2	1	0
16384d	0	1	0	0	0	0	0	0	0	0	0	0	0	0	0	0
	0	0	0	0	0	0	0	0	0	0	0	0	0	0	0	0
256d	STW2 Bit															
	15	14	13	12	11	10	9	8	7	6	5	4	3	2	1	0
256d	0	0	0	0	0	0	0	1	0	0	0	0	0	0	0	0
	0	0	0	0	0	0	0	0	0	0	0	0	0	0	0	0

8.5.4 DCX Outputs/PLC Inputs (20 words)

Table 8.9 DCX Outputs/PLC Inputs (20 words)

Data	Description	Data Type	Access	Unit	Notes	
0	Reserved		R			
1	Reserved					
2	ZSW1 (ZSW Word 1)	UINT16		-	-	See Table 8.10 and Table 8.13
3	ZSW2 (ZSW Word 2)			-		
4	Nominal Amplitude Set			%		
5	Amplitude Output			%		
6	Current			%		
7	Power			%		
8	Phase	INT16		°		
9	PWM	UINT16		%		
10	Frequency			Hz		
11	Temperature		C			
12	Reserved					
13	Reserved					
14	Reserved					
15	Reserved					
16	Reserved					
17	Reserved					
18	Reserved					
19	Reserved					

8.5.4.1 Status Word (ZSW1)

Table 8.10 Status Word (ZSW1)

	Bit	Name	Description	Notes
ZSW1	0	NO-B	Non Cycle Overload Group B	1 = Non cycle overload has occurred
	1	ES	Emergency Stop Active	1 = Emergency stop active
	2	TEE	Future Use	Not used
	3	HFSE		
	4	HFS0	Stack Preset Number 0 Status	See Table 8.11 HFS Bit (Status Word) .
	5	HFS1	Stack Preset Number 1 Status	
	6	HFS2	Stack Preset Number 2 Status	
	7	HFS3	Stack Preset Number 3 Status	
	8	PSN0	Weld Preset Number 0 Active	See Table 8.12 PSN Bit (Status Word) .
	9	PSN1	Weld Preset Number 1 Active	
	10	PSN2	Weld Preset Number 2 Active	
	11	PSN3	Weld Preset Number 3 Active	
	12	PSN4	Weld Preset Number 4 Active	
	13	PSCA	Preset Change Complete	1 = Preset change complete
	14	MA	Manual/Auto Mode Active	1 = Auto Mode
15	OL-0	Overload Group 0	1 = Overload has occurred	

HSF Bit (Status Word)

Table 8.11 HFS Bit (Status Word)

HFS3	HFS2	HFS1	HFS0	Stack Active
0	0	0	0	Not valid
0	0	0	1	1
0	0	1	0	2
0	0	1	1	3
0	1	0	0	4
0	1	0	1	5
0	1	1	0	6
0	1	1	1	7
1	0	0	0	8
1	0	0	1	9
1	0	1	0	10
1	0	1	1	11
1	1	0	0	12
1	1	0	1	13
1	1	1	0	14
1	1	1	1	15

PSN Bit (Status Word)

Table 8.12 PSN Bit (Status Word)

PSN4	PSN3	PSN2	PSN1	PSN0	Preset Active
0	0	0	0	0	No preset active
0	0	0	0	1	1
0	0	0	1	0	2
0	0	0	1	1	3
0	0	1	0	0	4
0	0	1	0	1	5
0	0	1	1	0	6
0	0	1	1	1	7
0	1	0	0	0	8
0	1	0	0	1	9

Table 8.12 PSN Bit (Status Word)

PSN4	PSN3	PSN2	PSN1	PSN0	Preset Active
0	1	0	1	0	10
0	1	0	1	1	11
0	1	1	0	0	12
0	1	1	0	1	13
0	1	1	1	0	14
0	1	1	1	1	15
1	0	0	0	0	16
1	0	0	0	1	17
1	0	0	1	0	18
1	0	0	1	1	19
1	0	1	0	0	20
1	0	1	0	1	21
1	0	1	1	0	22
1	0	1	1	1	23
1	1	0	0	0	24
1	1	0	0	1	25
1	1	0	1	0	26
1	1	0	1	1	27
1	1	1	0	0	28
1	1	1	0	1	29
1	1	1	1	0	30
1	1	1	1	1	31

8.5.4.2 Status Word (ZSW2)

Table 8.13 Status Word (ZSW2)

	Bit	Name	Description	Notes
ZSW2	0	SE-2	Setup Group 2	1 = Setup alarm has occurred
	1	CM-3	Cycle Modified Group 3	1 = Cycle modified alarm has occurred
	2	WA-4	Warning Group 4	1 = Warning alarm has occurred
	3	EQ-6	Equipment Failure Group 6	1 = Equipment failure alarm has occurred
	4	NC-7	No Cycle Group 7	1 = No cycle alarm has occurred
	5	CF-8	Communication Failure Group 8	1 = Communication alarm has occurred
	6	HW-A	Hardware Group A	1 = Hardware alarm has occurred
	7	CU-1	Cutoff Group 1	1 = Cutoff alarm has occurred
	8	TP-9	Future Use	Not used
	9	SM	Future Use	Not used
	10	OFF	Ultrasonics Off and DCX Ready	1 = Ultrasonics off and DCX ready
	11	ON	Ultrasonics Active	1 = Ultrasonics active
	12	OK	End of Weld Cycle Without Error	1 = End cycle without error
	13	LM-5	Limit Group 5	1 = Limit alarm has occurred
	14	MCLR	Memory Clear	1 = Memory offset will be set to 0
15	RES	Reserved	Not used	

8.5.5 Implicit Message for Run

Table 8.14 Implicit Message for Run

Value	STW1 Bit															
16384d	15	14	13	12	11	10	9	8	7	6	5	4	3	2	1	0
	0	1	0	0	0	0	0	0	0	0	0	0	0	0	0	0
	STW2 Bit															
513d	15	14	13	12	11	10	9	8	7	6	5	4	3	2	1	0
	0	0	0	0	0	0	1	0	0	0	0	0	0	0	0	1

8.5.6 Implicit Message for Seek

Table 8.15 Implicit Message for Seek

Value	STW1 Bit															
	15	14	13	12	11	10	9	8	7	6	5	4	3	2	1	0
16384d	15	14	13	12	11	10	9	8	7	6	5	4	3	2	1	0
	0	1	0	0	0	0	0	0	0	0	0	0	0	0	0	0
Value	STW2 Bit															
	15	14	13	12	11	10	9	8	7	6	5	4	3	2	1	0
514d	15	14	13	12	11	10	9	8	7	6	5	4	3	2	1	0
	0	0	0	0	0	0	1	0	0	0	0	0	0	0	1	0

8.5.7 Implicit Message for Scan

Table 8.16 Implicit Message for Scan

Value	STW1 Bit															
	15	14	13	12	11	10	9	8	7	6	5	4	3	2	1	0
16384d	15	14	13	12	11	10	9	8	7	6	5	4	3	2	1	0
	0	1	0	0	0	0	0	0	0	0	0	0	0	0	0	0
Value	STW2 Bit															
	15	14	13	12	11	10	9	8	7	6	5	4	3	2	1	0
522d	15	14	13	12	11	10	9	8	7	6	5	4	3	2	1	0
	0	0	0	0	0	0	1	0	0	0	0	0	1	0	1	0

8.6 Explicit Messaging

NOTICE	
	See Appendix B: EtherNet/IP Commands for a full listing of Explicit Messaging.

8.6.1 Getting Token

In order to use Explicit Messaging, *Token* must be obtained. Token allows the PLC Explicit Communication between the PLC and DCX.

The following is an example for establishing Token using Explicit Messaging. The information is extracted from [B.8 Other Information Class 112 \(1 Instances\)](#).

Change values in Message Configuration for RSLogix 5000 Message Configuration to establish as follows:

Table 8.17 Getting Token

Name	Value
Class	112 (70 hex)
Attribute	50 (32 hex)
Instance	0 (DCX Preset Location 0)
Service Code/Type	Get = 14 (e hex)
Destination	Tag/register were the data is being sent

Table 8.18 Attribute ID

Attribute ID	Description	Data Type	Access
50	Get Access Token	UINT8	Get
51	Put Access Token	UINT8	Get/Set

Table 8.19 Common Services

Service Code	Service Name
14	Get_Attribute_Single
16	Set_Attribute_Single

8.6.1.1 RSLogix 5000 Implementation of Token

Getting Token must be established prior to the exchange of explicit messaging.

Figure 8.3 RSLogix 5000 Implementation of Token

Table 8.20 RSLogix 5000 Implementation of Token

Name	Value
Message Type	Select <i>CIP Generic</i> from the drop down menu.
Service Type	Select <i>Get Attribute Single</i> from the drop down menu.
Service Code	Value comes from the service type command.
Class	Object reference of DCX EtherNet/IP Commands. See Appendix B: EtherNet/IP Commands .
Instance	Preset location. 32 locations (Token uses Location 0).
Attribute	Parameter reference (Attribute ID). See Appendix B: EtherNet/IP Commands .
Destination	Tag/Register storage location in PLC for acquired DCX data.

8.6.1.2 Web Page Indication of Token Being Established

Confirmation of Token can be checked by accessing the DCX F EIP Web Page Interface.

The illumination of the radio button will turn red indicating Token (PLC control) has been obtained.

Figure 8.4 Web Page Indication of Token Being Established

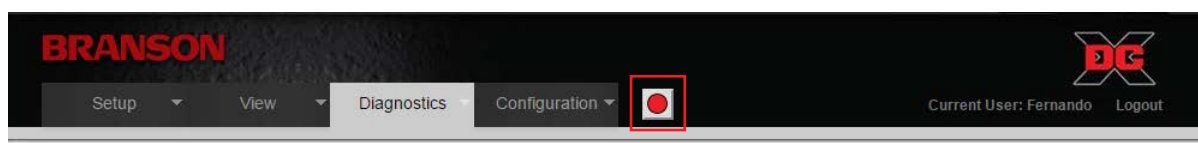

8.6.1.3 RSLogix 5000 Implementation of Token Release

Figure 8.5 RSLogix 5000 Implementation of Token Release

Table 8.21 RSLogix 5000 Implementation of Token Release

Name	Value
Message Type	Select <i>CIP Generic</i> from the drop down menu.
Service Type	Select <i>Get Attribute Single</i> from the drop down menu.
Service Code	Value comes from the service type command.
Class	Object reference of DCX EtherNet/IP Commands. See Appendix B: EtherNet/IP Commands .
Instance	Preset location. 32 locations (Token uses Location 0).
Attribute	Parameter reference (Attribute ID). See Appendix B: EtherNet/IP Commands .
Source Element	Tag/Register storage location in PLC for acquired DCX data.

8.6.1.4 Web Page Indication of Token Being Released

Confirmation of Token can be checked by accessing the DCX F EIP Web Page Interface. The illumination of the radio button will turn green indicating Token (PLC control) has been released.

Figure 8.6 Web Page Indication of Token Being Released

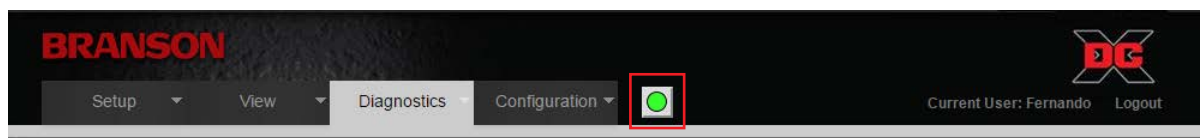

8.6.2 Obtaining (Get) Information from DCX

8.6.2.1 Get Energy Value Example

The following is an example for extracting Energy Value using Explicit Messaging. The information is extracted from [B.2 Weld Data Class 101 \(32 Instances\)](#).

Change values in Message Configuration for RSLogix5000 Message Configuration as follows:

Table 8.22 Get Energy Value Example

Name	Value
Class	101 (65 hex)
Attribute	1362 (552 hex)
Instance	1 (DCX Preset Location 1)
Service Code/Type	Get = 14 (e hex)
Destination	Tag/Register were the data is being sent (energy value from last weld cycle)

Table 8.23 Attribute ID

Attribute ID	Description	Data Type	Access
1362	Energy	UINT8	Get

Table 8.24 Common Services

Service Code	Service Name
14	Get_Attribute_Single

8.6.2.2 RSLogix 5000 Implementation of Get Energy Value

Figure 8.7 RSLogix 5000 Implementation of Get Energy Value

Message Configuration - Get_DCX_message_1

Configuration Communication Tag

Message Type: CIP Generic

Service Type: Get Attribute Single Source Element: []

Service Code: e (Hex) Class: 65 (Hex) Source Length: 0 (Bytes)

Instance: 0 Attribute: 552 (Hex) Destination: Get_Class_Attribute_V []

[New Tag...]

Enable Enable Waiting Start Done Done Length: 4

Error Code: Extended Error Code: Timed Out

Error Path:
Error Text:

[OK] [Cancel] [Apply] [Help]

Table 8.25 RSLogix 5000 Implementation of Get Energy Value

Name	Value
Message Type	Select <i>CIP Generic</i> from the drop down menu.
Service Type	Select <i>Get Attribute Single</i> from the drop down menu.
Service Code	Value comes from the service type command.
Class	Class reference of DCX EtherNet/IP Commands. See Appendix B: EtherNet/IP Commands .
Instance	Preset location. 32 locations (location 0 is the active/running location).
Attribute	Parameter reference (Attribute ID). See Appendix B: EtherNet/IP Commands .
Source Element	Tag/Register storage location in PLC for acquired DCX data.

8.6.3 Sending (Set) Parameter Values to DCX

8.6.3.1 Set Energy Value Example

The following is an example for sending the Energy Value using Explicit Messaging. The information is extracted from [B.1 Parameter Set Class 100 \(32 Instances\)](#).

Change values in Message Configuration for RSlogix5000 Message Configuration as follows:

Table 8.26 Set Energy Value Example

Name	Value
Class	101 (66 hex)
Attribute	1062 (426 hex)
Instance	0 (DCX Preset Location 0)
Service Code/Type	Set = 16 (10 hex)
Destination	Tag/Register were the data is being sent (energy value to DCX)

Table 8.27 Attribute ID

Attribute ID	Description	Data Type	Access
1062	Energy	AINT32	Get/Set

Table 8.28 Common Services

Service Code	Service Name
16	Set_Attribute_Single

8.6.3.2 RSLogix 5000 Implementation of Set Energy Value

Figure 8.8 RSLogix 5000 Implementation of Set Energy Value

Message Configuration - Set_DCX_message_1

Configuration Communication Tag

Message Type: CIP Generic

Service Type: Set Attribute Single Source Element: Set_Class_valve_1

Source Length: 4 (Bytes)

Service Code: 10 (Hex) Class: 64 (Hex) Destination: tem_class_1

Instance: 0 Attribute: 426 (Hex) New Tag...

Enable
 Enable Waiting
 Start
 Done
 Done Length: 4

Error Code: 16#000
 Extended Error Code:
 Timed Out

Error Path: DCX_32_IP

Error Text: Access permission denied for requested service

OK Cancel Apply Help

Table 8.29 RSLogix 5000 Implementation of Set Energy Value

Name	Value
Message Type	Select <i>CIP Generic</i> from the drop down menu.
Service Type	Select <i>Set Attribute Single</i> from the drop down menu.
Service Code	Value comes from the service type command.
Class	Class reference of DCX EtherNet/IP Commands. See Appendix B: EtherNet/IP Commands .
Instance	Preset location. 32 locations (location 0 is the active/running location).
Attribute	Parameter reference (Attribute ID). See Appendix B: EtherNet/IP Commands .
Source Element	Tag/Register storage location in PLC for where DCX will be getting data from.

8.7 Implicit Messaging - Control/Status Word

8.7.1 Control/Status Word Example

The following examples will demonstrate the use of Implicit Messaging in performing a typical weld cycle. RSLogix 5000 Controller Tags will be used for this demonstration without need of a PLC program.

Refer to [8.4 Communication to the CompactLogix Via EtherNet/IP](#) for information on setting up the communication to the CompactLogix AB Controller via EtherNet/IP.

The DCX F-EIP is setup to operate in Time mode.

Table 8.30 Control/Status Word (Time Mode)

Name	Value
Weld Time	5.0 s
Hold Time	10.0 s

The examples will concentrate on the Control (ZSW) and Status (STW) words, since these are the items that control and monitor the DCX cycling through the fieldbus.

[Table 8.31](#) is the information that the DCX will send to the PLC. This is the "Status" information from the DCX.

Table 8.31 DCX Outputs/PLC Inputs (20 words)

Data	Description	Data Type	Access	Unit	Notes
0	Reserved	UINT16	R		
1	Reserved				
2	ZSW1 (ZSW Word 1)			-	See Table 8.10 and Table 8.13
3	ZSW2 (ZSW Word 2)			-	
4	Nominal Amplitude Set			%	
5	Amplitude Output			%	
6	Current			%	
7	Power	%			
8	Phase	INT16		°	
9	PWM	UINT16		%	
10	Frequency			Hz	
11	Temperature			C	
12	Reserved				
13	Reserved				
14	Reserved				
15	Reserved				

Table 8.31 DCX Outputs/PLC Inputs (20 words)

Data	Description	Data Type	Access	Unit	Notes
16	Reserved				
17	Reserved				
18	Reserved				
19	Reserved				

[Table 8.32](#) is the information that the DCX will received from the PLC. This is the "Control" information to the DCX.

Table 8.32 DCX Inputs/PLC Outputs (20 words)

Data	Description	Data Type	Access	Unit	Notes
0	STW1 (STW Word 1)	UINT16	W	-	See Table 8.3 and Table 8.6
1	SWT2 (STW Word 2)			-	
2	External Amplitude			%	
3	Frequency Offset			Hz	
4-19	Reserved				

8.7.2 DCX Initial State – No commands are being sent by PLC

PLC Output STW1/STW2 = 0

Figure 8.9 PLC Output STW1/STW2 = 0

[+] DCX_32_IP.O	{..}	{..}		AB:ETHERNET_	
[-] DCX_32_IP.O.Data	{..}	{..}	Decimal	INT[20]	
[+] DCX_32_IP.O.Data[0]	0		Decimal	INT	stw1
[+] DCX_32_IP.O.Data[1]	0		Decimal	INT	stw2
[+] DCX_32_IP.O.Data[2]	0		Decimal	INT	ampl out
[+] DCX_32_IP.O.Data[3]	0		Decimal	INT	freq offset

PLC Input ZSW1= 16, ZSW2=1024

Note that Live Channel information is also preset (Sonics Off condition shown).

Figure 8.10 PLC Input ZSW1= 16, ZSW2=1024

[+] DCX_32_IP.I	{..}	{..}		AB:ETHERNET_	
[-] DCX_32_IP.I.Data	{..}	{..}	Decimal	INT[20]	
[+] DCX_32_IP.I.Data[0]	1		Decimal	INT	
[+] DCX_32_IP.I.Data[1]	0		Decimal	INT	
[+] DCX_32_IP.I.Data[2]	16		Decimal	INT	zsw1
[+] DCX_32_IP.I.Data[3]	1024		Decimal	INT	zsw2
[+] DCX_32_IP.I.Data[4]	74		Decimal	INT	set norm value
[+] DCX_32_IP.I.Data[5]	0		Decimal	INT	ampl Out
[+] DCX_32_IP.I.Data[6]	0		Decimal	INT	current
[+] DCX_32_IP.I.Data[7]	0		Decimal	INT	power
[+] DCX_32_IP.I.Data[8]	0		Decimal	INT	phase
[+] DCX_32_IP.I.Data[9]	0		Decimal	INT	pwm
[+] DCX_32_IP.I.Data[10]	30166		Decimal	INT	freq
[+] DCX_32_IP.I.Data[11]	37		Decimal	INT	temp

DCX Fieldbus Diagnostic

- STW1 show no LEDs illuminated (00000000 binary)
- STW2 show no LEDs illuminated (00000000 binary)
- ZSW1/H: HFS0 bit 4 being illuminated (00010000 binary)
- ZSW1/L: Show no LEDs illuminated (00000000 binary)
- ZSW2/H: HFS0 bit 11 being illuminated (00001000 binary)
- ZSW2/L: Show no LEDs illuminated (00000000 binary)

Figure 8.11 DCX Fieldbus Diagnostic

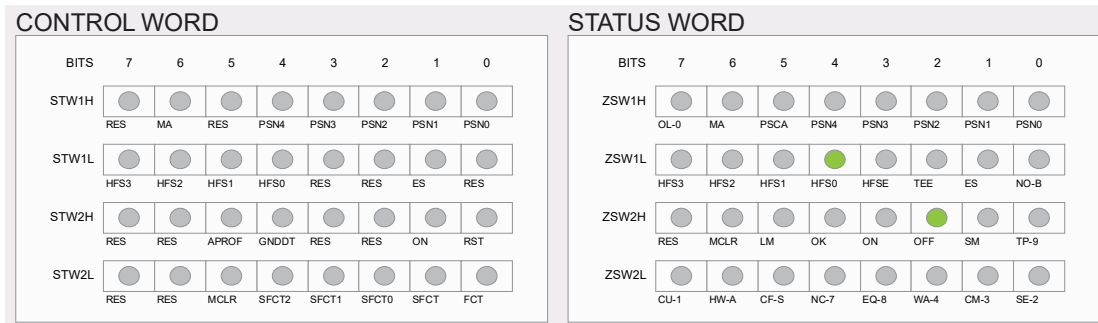

8.7.3 DCX Weld Mode - Sending a 513 command - Weld Time.

STW2 needs to stay in Auto mode (bit 14) -16384 command. Here we will pick the bits from STW2 that will start sonics.

To turn on sonics the Weld Function (FCT bit0) and Run Ultrasonics (ON, Bit 8) will be sent to the DCX thus creating a DCX Start Function. This will create the command 513 that will be sent to STW2.

Figure 8.12 DCX Weld Mode - Sending a 513 Command - Weld Time

[+] DCX_32_IP.I	{..}	{..}		AB:ETHERNET_	
[+] DCX_32_IP.I.Data	{..}	{..}	Decimal	INT[20]	
[+] DCX_32_IP.I.Data[0]	1		Decimal	INT	
[+] DCX_32_IP.I.Data[1]	0		Decimal	INT	
[+] DCX_32_IP.I.Data[2]	16400		Decimal	INT	zsw1
[+] DCX_32_IP.I.Data[3]	2048		Decimal	INT	zsw2
[+] DCX_32_IP.I.Data[4]	49		Decimal	INT	set norm value
[+] DCX_32_IP.I.Data[5]	49		Decimal	INT	ampl Out
[+] DCX_32_IP.I.Data[6]	29		Decimal	INT	current
[+] DCX_32_IP.I.Data[7]	14		Decimal	INT	power
[+] DCX_32_IP.I.Data[8]	0		Decimal	INT	phase
[+] DCX_32_IP.I.Data[9]	24		Decimal	INT	pwm
[+] DCX_32_IP.I.Data[10]	30166		Decimal	INT	freq
[+] DCX_32_IP.I.Data[11]	32		Decimal	INT	temp
[+] DCX_32_IP.I.Data[12]	0		Decimal	INT	
[+] DCX_32_IP.I.Data[13]	0		Decimal	INT	
[+] DCX_32_IP.I.Data[14]	0		Decimal	INT	
[+] DCX_32_IP.I.Data[15]	0		Decimal	INT	
[+] DCX_32_IP.I.Data[16]	0		Decimal	INT	
[+] DCX_32_IP.I.Data[17]	0		Decimal	INT	
[+] DCX_32_IP.I.Data[18]	0		Decimal	INT	
[+] DCX_32_IP.I.Data[19]	0		Decimal	INT	
[+] DCX_32_IP.O	{..}	{..}		AB:ETHERNET_	
[+] DCX_32_IP.O.Data	{..}	{..}	Decimal	INT[20]	
[+] DCX_32_IP.O.Data[0]	16384		Decimal	INT	stw1
[+] DCX_32_IP.O.Data[1]	513		Decimal	INT	stw2

DCX Fieldbus Diagnostic

Note that the PLC Commands and responses will be mirrored in the DCX Control and Status Words.

Figure 8.13 DCX Fieldbus Diagnostic Page

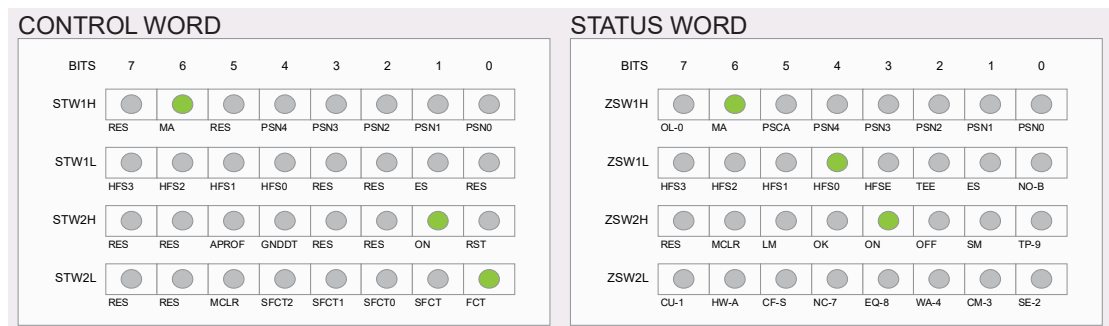

8.7.4 DCX Weld Mode - Sending a 513 Command - Hold Time

No changes will be made to the STW1/STW2 from prior example. The MA and ON bit will continued to be sent to the DCX.

Here we will see the ZSW2 response has changed from Weld Time (sonics On) to Hold Time (sonics Off). Note that the ZSW2 has changes from 2048 to 0 indicating Sonics is OFF. This is the Hold Time State.

Figure 8.14 DCX Weld Mode - Sending a 513 Command - Hold Time

[+] DCX_32_IP.I	{..}	{..}		AB:ETHERNET_	
[+] DCX_32_IP.I.Data	{..}	{..}	Decimal	INT[20]	
[+] DCX_32_IP.I.Data[0]	1		Decimal	INT	
[+] DCX_32_IP.I.Data[1]	0		Decimal	INT	
[+] DCX_32_IP.I.Data[2]	16400		Decimal	INT	zsw1
[+] DCX_32_IP.I.Data[3]	0		Decimal	INT	zsw2
[+] DCX_32_IP.I.Data[4]	49		Decimal	INT	set norm value
[+] DCX_32_IP.I.Data[5]	0		Decimal	INT	ampl Out
[+] DCX_32_IP.I.Data[6]	0		Decimal	INT	current
[+] DCX_32_IP.I.Data[7]	0		Decimal	INT	power
[+] DCX_32_IP.I.Data[8]	0		Decimal	INT	phase
[+] DCX_32_IP.I.Data[9]	0		Decimal	INT	pwm
[+] DCX_32_IP.I.Data[10]	30195		Decimal	INT	freq
[+] DCX_32_IP.I.Data[11]	32		Decimal	INT	temp
[+] DCX_32_IP.I.Data[12]	0		Decimal	INT	
[+] DCX_32_IP.I.Data[13]	0		Decimal	INT	
[+] DCX_32_IP.I.Data[14]	0		Decimal	INT	
[+] DCX_32_IP.I.Data[15]	0		Decimal	INT	
[+] DCX_32_IP.I.Data[16]	0		Decimal	INT	
[+] DCX_32_IP.I.Data[17]	0		Decimal	INT	
[+] DCX_32_IP.I.Data[18]	0		Decimal	INT	
[+] DCX_32_IP.I.Data[19]	0		Decimal	INT	
[+] DCX_32_IP.O	{..}	{..}		AB:ETHERNET_	
[+] DCX_32_IP.O.Data	{..}	{..}	Decimal	INT[20]	
[+] DCX_32_IP.O.Data[0]	16384		Decimal	INT	stw1
[+] DCX_32_IP.O.Data[1]	513		Decimal	INT	stw2

DCX Fieldbus Diagnostic

Note that the ZSW2 ON bit 11 is now Off also indicating Sonics is OFF. This is the Hold Time State.

Figure 8.15 DCX Fieldbus Diagnostic

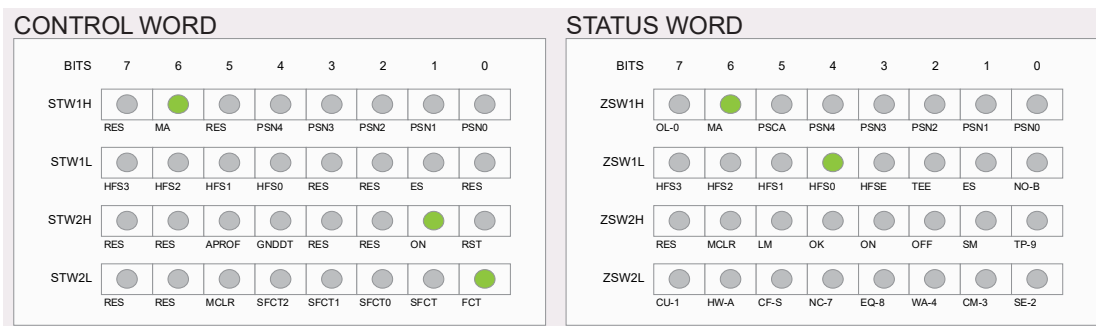

8.7.5 DCX Weld Mode - Sending a 0 command - Changeover State

STW1 needs to stay in Auto mode (bit 14) -16384 command. STW2 from prior example. The MA and ON bit will continued to be sent to the DCX. A command 0 will be sent to STW2 to release the FCT (bit0) and On (bit 8) thus removing the DCX Start Function.

Here we will see the ZSW2 response has changed from Hold Time to End of Weld Cycle. Note that the ZSW2 has changes from 0 to 5120 indicating Weld Cycle is complete.

Figure 8.16 DCX Weld Mode - Sending a 0 Command - Changeover State

[-] DCX_32_IP.I	{..}	{..}		AB:ETHERNET_	
[-] DCX_32_IP.I.Data	{..}	{..}	Decimal	INT[20]	
[+] DCX_32_IP.I.Data[0]	1		Decimal	INT	
[+] DCX_32_IP.I.Data[1]	0		Decimal	INT	
[+] DCX_32_IP.I.Data[2]	16400		Decimal	INT	zsw1
[+] DCX_32_IP.I.Data[3]	5120		Decimal	INT	zsw2
[+] DCX_32_IP.I.Data[4]	49		Decimal	INT	set norm value
[+] DCX_32_IP.I.Data[5]	0		Decimal	INT	ampl Out
[+] DCX_32_IP.I.Data[6]	0		Decimal	INT	current
[+] DCX_32_IP.I.Data[7]	0		Decimal	INT	power
[+] DCX_32_IP.I.Data[8]	0		Decimal	INT	phase
[+] DCX_32_IP.I.Data[9]	0		Decimal	INT	pwm
[+] DCX_32_IP.I.Data[10]	30194		Decimal	INT	freq
[+] DCX_32_IP.I.Data[11]	33		Decimal	INT	temp
[+] DCX_32_IP.I.Data[12]	0		Decimal	INT	
[+] DCX_32_IP.I.Data[13]	0		Decimal	INT	
[+] DCX_32_IP.I.Data[14]	0		Decimal	INT	
[+] DCX_32_IP.I.Data[15]	0		Decimal	INT	
[+] DCX_32_IP.I.Data[16]	0		Decimal	INT	
[+] DCX_32_IP.I.Data[17]	0		Decimal	INT	
[+] DCX_32_IP.I.Data[18]	0		Decimal	INT	
[+] DCX_32_IP.I.Data[19]	0		Decimal	INT	
[-] DCX_32_IP.O	{..}	{..}		AB:ETHERNET_	
[-] DCX_32_IP.O.Data	{..}	{..}	Decimal	INT[20]	
[+] DCX_32_IP.O.Data[0]	16384		Decimal	INT	stw1
[+] DCX_32_IP.O.Data[1]	0		Decimal	INT	stw2

DCX Fieldbus Diagnostic

Note that none of the STW2 bits are active, thus mirroring the STW2 "0" command sent by the PLC. The ZSW2 shows End of Weld Cycle (Bit 12) and Ultrasonics OFF (bit 10) illuminated indicating Weld cycle is complete.

Figure 8.17 DCX Fieldbus Diagnostic Page

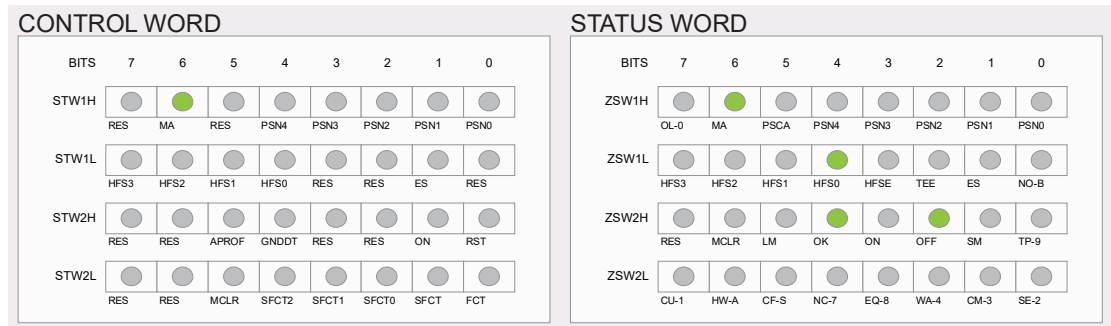

8.7.6 DCX Weld Mode - Sending a 513 Command and Holding It to Create a "Start Input is Active" Alarm

A 513 command will be sent and held constant to STW2 FCT (bit0) and On (bit 8) to invoke a DCX Start Function. (Refer to Weld Time Example). At some point after the Weld Cycle is complete a "Start Input is Active" alarm will be generated at the DCX. Note that the ZSW2 is 4104 indicating a Equipment failure has occurred.

Figure 8.18 DCX Weld Mode - Sending a 513 Command and Holding It to Create a "Start Input is Active" Alarm

[+] DCX_32_IP.I	{ . . }	{ . . }		AB:ETHERNET_	
[-] DCX_32_IP.I.Data	{ . . }	{ . . }	Decimal	INT[20]	
[+] DCX_32_IP.I.Data[0]	1		Decimal	INT	
[+] DCX_32_IP.I.Data[1]	0		Decimal	INT	
[+] DCX_32_IP.I.Data[2]	16400		Decimal	INT	zsw1
[+] DCX_32_IP.I.Data[3]	4104		Decimal	INT	zsw2
[+] DCX_32_IP.I.Data[4]	49		Decimal	INT	set norm value
[+] DCX_32_IP.I.Data[5]	0		Decimal	INT	ampl Out
[+] DCX_32_IP.I.Data[6]	0		Decimal	INT	current
[+] DCX_32_IP.I.Data[7]	0		Decimal	INT	power
[+] DCX_32_IP.I.Data[8]	0		Decimal	INT	phase
[+] DCX_32_IP.I.Data[9]	0		Decimal	INT	pwm
[+] DCX_32_IP.I.Data[10]	30195		Decimal	INT	freq
[+] DCX_32_IP.I.Data[11]	33		Decimal	INT	temp
[+] DCX_32_IP.I.Data[12]	0		Decimal	INT	
[+] DCX_32_IP.I.Data[13]	0		Decimal	INT	
[+] DCX_32_IP.I.Data[14]	0		Decimal	INT	
[+] DCX_32_IP.I.Data[15]	0		Decimal	INT	
[+] DCX_32_IP.I.Data[16]	0		Decimal	INT	
[+] DCX_32_IP.I.Data[17]	0		Decimal	INT	
[+] DCX_32_IP.I.Data[18]	0		Decimal	INT	
[+] DCX_32_IP.I.Data[19]	0		Decimal	INT	
[-] DCX_32_IP.O	{ . . }	{ . . }		AB:ETHERNET_	
[-] DCX_32_IP.O.Data	{ . . }	{ . . }	Decimal	INT[20]	
[+] DCX_32_IP.O.Data[0]	16384		Decimal	INT	stw1
[+] DCX_32_IP.O.Data[1]	513		Decimal	INT	stw2

DCX Fieldbus Diagnostic

Note that STW2 Shows ON and FCT still being active (the 513 command). The ZSW2 show the OK and EQ8 LEDs being active.

Figure 8.19 DCX Fieldbus Diagnostics

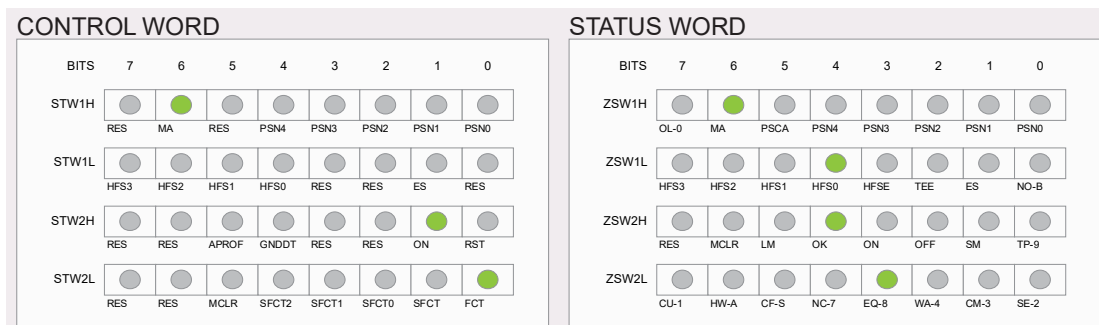

8.7.7 DCX Weld Mode - Alarm Reset

Using the prior “Start Input is Active” alarm example, we will send a Reset command to clear the alarm condition.

For this to occur the 513 command (DCX Start Function) will be removed first. We will send a command 0 to release the DCX Start function. Then we will send a command 256 to Reset the DCX alarm. Once the Alarm is Reset a 0 command will be sent to release the Reset command. Note that the ZSW2 is 5128 indicating a Equipment failure has occurred.

Figure 8.20 DCX Weld Mode - Alarm Reset

[+] DCX_32_IP.I	{..}	{..}		AB:ETHERNET_	
[+] DCX_32_IP.I.Data	{..}	{..}	Decimal	INT[20]	
[+] DCX_32_IP.I.Data[0]	1		Decimal	INT	
[+] DCX_32_IP.I.Data[1]	0		Decimal	INT	
[+] DCX_32_IP.I.Data[2]	16400		Decimal	INT	zsw1
[+] DCX_32_IP.I.Data[3]	5128		Decimal	INT	zsw2
[+] DCX_32_IP.I.Data[4]	49		Decimal	INT	set norm value
[+] DCX_32_IP.I.Data[5]	0		Decimal	INT	ampl Out
[+] DCX_32_IP.I.Data[6]	0		Decimal	INT	current
[+] DCX_32_IP.I.Data[7]	0		Decimal	INT	power
[+] DCX_32_IP.I.Data[8]	0		Decimal	INT	phase
[+] DCX_32_IP.I.Data[9]	0		Decimal	INT	pwm
[+] DCX_32_IP.I.Data[10]	30195		Decimal	INT	freq
[+] DCX_32_IP.I.Data[11]	32		Decimal	INT	temp
[+] DCX_32_IP.I.Data[12]	0		Decimal	INT	
[+] DCX_32_IP.I.Data[13]	0		Decimal	INT	
[+] DCX_32_IP.I.Data[14]	0		Decimal	INT	
[+] DCX_32_IP.I.Data[15]	0		Decimal	INT	
[+] DCX_32_IP.I.Data[16]	0		Decimal	INT	
[+] DCX_32_IP.I.Data[17]	0		Decimal	INT	
[+] DCX_32_IP.I.Data[18]	0		Decimal	INT	
[+] DCX_32_IP.I.Data[19]	0		Decimal	INT	
[+] DCX_32_IP.O	{..}	{..}		AB:ETHERNET_	
[+] DCX_32_IP.O.Data	{..}	{..}	Decimal	INT[20]	
[+] DCX_32_IP.O.Data[0]	16384		Decimal	INT	stw1
[+] DCX_32_IP.O.Data[1]	0		Decimal	INT	stw2

DCX Fieldbus Diagnostic

Note that STW2 Shows ON and FCT are now OFF (the 0 command). The ZSW2 show the OFF and EQ8 LEDs being active.

8.7.7.1 DCX Weld Mode - Alarm Reset (Cont)

STW2 shows the 256 Command being sent to Reset the DCX alarm. ZSW2 response 1024 indicates that Alarm is Reset and the DCX is in the Ready state.

Figure 8.21 DCX Weld Mode - Alarm Reset (Cont)

[-] DCX_32_IP.I	{...}	{...}		AB:ETHERNET_	
[-] DCX_32_IP.I.Data	{...}	{...}	Decimal	INT[20]	
[+] DCX_32_IP.I.Data[0]	1		Decimal	INT	
[+] DCX_32_IP.I.Data[1]	0		Decimal	INT	
[+] DCX_32_IP.I.Data[2]	16400		Decimal	INT	zsw1
[+] DCX_32_IP.I.Data[3]	1024		Decimal	INT	zsw2
[+] DCX_32_IP.I.Data[4]	49		Decimal	INT	set norm value
[+] DCX_32_IP.I.Data[5]	0		Decimal	INT	ampl Out
[+] DCX_32_IP.I.Data[6]	0		Decimal	INT	current
[+] DCX_32_IP.I.Data[7]	0		Decimal	INT	power
[+] DCX_32_IP.I.Data[8]	0		Decimal	INT	phase
[+] DCX_32_IP.I.Data[9]	0		Decimal	INT	pwm
[+] DCX_32_IP.I.Data[10]	30195		Decimal	INT	freq
[+] DCX_32_IP.I.Data[11]	32		Decimal	INT	temp
[+] DCX_32_IP.I.Data[12]	0		Decimal	INT	
[+] DCX_32_IP.I.Data[13]	0		Decimal	INT	
[+] DCX_32_IP.I.Data[14]	0		Decimal	INT	
[+] DCX_32_IP.I.Data[15]	0		Decimal	INT	
[+] DCX_32_IP.I.Data[16]	0		Decimal	INT	
[+] DCX_32_IP.I.Data[17]	0		Decimal	INT	
[+] DCX_32_IP.I.Data[18]	0		Decimal	INT	
[+] DCX_32_IP.I.Data[19]	0		Decimal	INT	
[-] DCX_32_IP.O	{...}	{...}		AB:ETHERNET_	
[-] DCX_32_IP.O.Data	{...}	{...}	Decimal	INT[20]	
[+] DCX_32_IP.O.Data[0]	16384		Decimal	INT	stw1
[+] DCX_32_IP.O.Data[1]	256		Decimal	INT	stw2

DCX Fieldbus Diagnostic

The ZSW2 show the OFF LED being active. The DCX is in the Ready State.

Figure 8.22 DCX Fieldbus Diagnostic

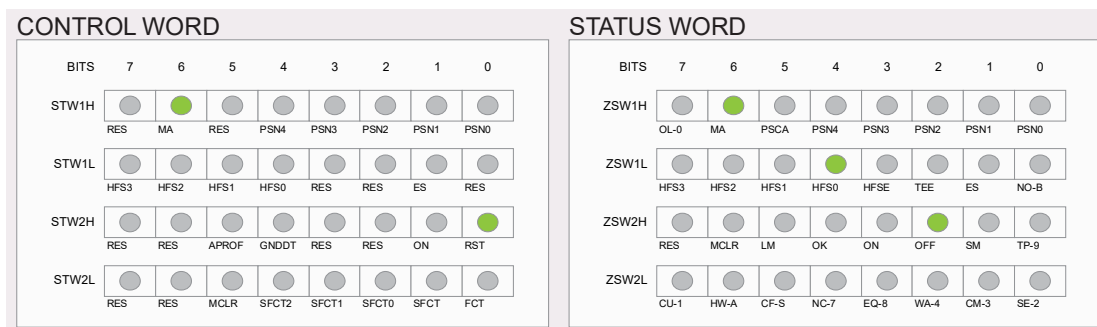

8.7.7.2 DCX Weld Mode - Alarm Reset (Cont)

STW2 shows the 0 Command being sent to release the Reset command to the DCX. ZSW2 response 1024 indicates that DCX is in the Ready state.

Figure 8.23 DCX Weld Mode - Alarm Reset (Cont)

[-] DCX_32_IP.I	{..}	{..}		AB:ETHERNET_	
[-] DCX_32_IP.I.Data	{..}	{..}	Decimal	INT[20]	
[+] DCX_32_IP.I.Data[0]	1		Decimal	INT	
[+] DCX_32_IP.I.Data[1]	0		Decimal	INT	
[+] DCX_32_IP.I.Data[2]	16400		Decimal	INT	zsw1
[+] DCX_32_IP.I.Data[3]	1024		Decimal	INT	zsw2
[+] DCX_32_IP.I.Data[4]	49		Decimal	INT	set norm value
[+] DCX_32_IP.I.Data[5]	0		Decimal	INT	ampl Out
[+] DCX_32_IP.I.Data[6]	0		Decimal	INT	current
[+] DCX_32_IP.I.Data[7]	0		Decimal	INT	power
[+] DCX_32_IP.I.Data[8]	0		Decimal	INT	phase
[+] DCX_32_IP.I.Data[9]	0		Decimal	INT	pwm
[+] DCX_32_IP.I.Data[10]	30195		Decimal	INT	freq
[+] DCX_32_IP.I.Data[11]	32		Decimal	INT	temp
[+] DCX_32_IP.I.Data[12]	0		Decimal	INT	
[+] DCX_32_IP.I.Data[13]	0		Decimal	INT	
[+] DCX_32_IP.I.Data[14]	0		Decimal	INT	
[+] DCX_32_IP.I.Data[15]	0		Decimal	INT	
[+] DCX_32_IP.I.Data[16]	0		Decimal	INT	
[+] DCX_32_IP.I.Data[17]	0		Decimal	INT	
[+] DCX_32_IP.I.Data[18]	0		Decimal	INT	
[+] DCX_32_IP.I.Data[19]	0		Decimal	INT	
[-] DCX_32_IP.O	{..}	{..}		AB:ETHERNET_	
[-] DCX_32_IP.O.Data	{..}	{..}	Decimal	INT[20]	
[+] DCX_32_IP.O.Data[0]	16384		Decimal	INT	stw1
[+] DCX_32_IP.O.Data[1]	0		Decimal	INT	stw2

DCX Fieldbus Diagnostic

STW2 shows no bits are active indicating that no commands (or command 0) is being sent by the PLC to the DCX. ZSW2 show the OFF LED being active. The DCX is in the Ready State and awaiting next Weld Cycle command.

Figure 8.24 DCX Fieldbus Diagnostic

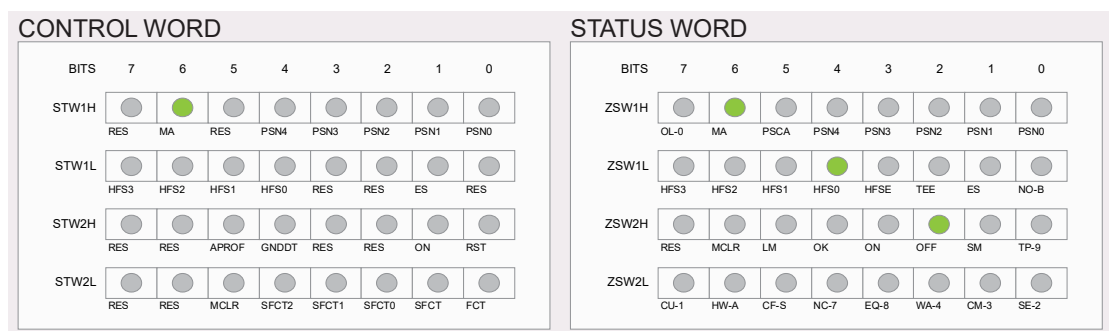

8.8 Implicit Messaging Live Channel

[Table 8.9 DCX Outputs/PLC Inputs \(20 words\)](#) is the information that the DCX will send to the PLC. This is the *Status* information from the DCX.

[Table 8.2 DCX Inputs/PLC Outputs \(20 words\)](#) is the information that the DCX will receive from the PLC. This is the *Control* information to the DCX.

During PLC setup/configuration, RSLogix 5000 is setup to reserve 20 locations of Input and Output (Connection Parameters) for Implicit Messaging.

Figure 8.25 Implicit Messaging

Module Properties: LocalENB (ETHERNET-MODULE 1.1)

General | Connection | Module Info

Type: ETHERNET-MODULE Generic Ethernet Module
 Vendor: Allen-Bradley
 Parent: LocalENB
 Name: DCX_32_IP
 Description:
 Comm Format: Data - INT
 Address / Host Name
 IP Address: 10 . 218 . 200 . 32
 IP Address:
 Connection Parameters

	Assembly Instance:	Size:	
Input:	101	20	(16-bit)
Output:	100	20	(16-bit)
Configuration:	102	0	(8-bit)
Status Input:			
Status Output:			

 Status: Running
 OK Cancel Apply Help

This Live Channel information can be viewed by opening the Controller Tag (RSLogix 5000) for each of the DCX devices.

Below is the PLC Output Data - Data going to the DCX (Control).

Figure 8.26 Data Going to the DCX (Control)

[+] DCX_32_IP.O	{...}	{...}		AB:ETHERNET_	
[+] DCX_32_IP.O.Data	{...}	{...}	Decimal	INT[20]	
[+] DCX_32_IP.O.Data[0]	16384		Decimal	INT	stw1
[+] DCX_32_IP.O.Data[1]	513		Decimal	INT	stw2
[+] DCX_32_IP.O.Data[2]	75		Decimal	INT	ampl out
[+] DCX_32_IP.O.Data[3]	3		Decimal	INT	freq offset
[+] DCX_32_IP.O.Data[4]	0		Decimal	INT	
[+] DCX_32_IP.O.Data[5]	0		Decimal	INT	
[+] DCX_32_IP.O.Data[6]	0		Decimal	INT	
[+] DCX_32_IP.O.Data[7]	0		Decimal	INT	
[+] DCX_32_IP.O.Data[8]	0		Decimal	INT	
[+] DCX_32_IP.O.Data[9]	0		Decimal	INT	
[+] DCX_32_IP.O.Data[10]	0		Decimal	INT	
[+] DCX_32_IP.O.Data[11]	0		Decimal	INT	
[+] DCX_32_IP.O.Data[12]	0		Decimal	INT	
[+] DCX_32_IP.O.Data[13]	0		Decimal	INT	
[+] DCX_32_IP.O.Data[14]	0		Decimal	INT	
[+] DCX_32_IP.I.Data[15]	0		Decimal	INT	
[+] DCX_32_IP.O.Data[16]	0		Decimal	INT	
[+] DCX_32_IP.O.Data[17]	0		Decimal	INT	
[+] DCX_32_IP.O.Data[18]	0		Decimal	INT	
[+] DCX_32_IP.O.Data[19]	0		Decimal	INT	

Below is the PLC Input Data - Data coming from the DCX (Status).

Figure 8.27 Data Coming from the DCX (Status)

[+] DCX_32_IP.I	{...}	{...}		AB:ETHERNET_	
[+] DCX_32_IP.I.Data	{...}	{...}	Decimal	INT[20]	
[+] DCX_32_IP.I.Data[0]	1		Decimal	INT	
[+] DCX_32_IP.I.Data[1]	0		Decimal	INT	
[+] DCX_32_IP.I.Data[2]	16400		Decimal	INT	zsw1
[+] DCX_32_IP.I.Data[3]	2048		Decimal	INT	zsw2
[+] DCX_32_IP.I.Data[4]	74		Decimal	INT	set norm value
[+] DCX_32_IP.I.Data[5]	75		Decimal	INT	ampl Out
[+] DCX_32_IP.I.Data[6]	44		Decimal	INT	current
[+] DCX_32_IP.I.Data[7]	34		Decimal	INT	power
[+] DCX_32_IP.I.Data[8]	0		Decimal	INT	phase
[+] DCX_32_IP.I.Data[9]	36		Decimal	INT	pwm
[+] DCX_32_IP.I.Data[10]	30164		Decimal	INT	freq
[+] DCX_32_IP.I.Data[11]	36		Decimal	INT	temp
[+] DCX_32_IP.I.Data[12]	0		Decimal	INT	
[+] DCX_32_IP.I.Data[13]	0		Decimal	INT	
[+] DCX_32_IP.I.Data[14]	0		Decimal	INT	
[+] DCX_32_IP.I.Data[15]	0		Decimal	INT	
[+] DCX_32_IP.I.Data[16]	0		Decimal	INT	
[+] DCX_32_IP.I.Data[17]	0		Decimal	INT	
[+] DCX_32_IP.I.Data[18]	0		Decimal	INT	
[+] DCX_32_IP.I.Data[19]	0		Decimal	INT	

The word fields for STW1/STW2 (Control Word) and ZSW1/ZSW2 (Status Word) can be expanded to view these words at the binary bit level.

8.8.1 Live PLC Input Channel Example (DCX Status Word)

The following example shows the PLC input channel expanded to bit level. The ZSW1 word "16400" is displayed at its binary level. Bit 4 (HFS0), and Bit 14 (MA) = 1 are shown as being active on the Diagnostics Fieldbus section on the DCX Web Page Interface.

Figure 8.28 DCX Status Word

[_] DCX_32_IP.I	{ . . }	{ . . }		AB:ETHERNET_	
[_] DCX_32_IP.I.Data	{ . . }	{ . . }	Decimal	INT[20]	
[+] DCX_32_IP.I.Data[0]	1		Decimal	INT	
[+] DCX_32_IP.I.Data[1]	0		Decimal	INT	
[_] DCX_32_IP.I.Data[2]	16400		Decimal	INT	zsw1
DCX_32_IP.I.Data[2].0	0		Decimal	BOOL	zsw1
DCX_32_IP.I.Data[2].1	0		Decimal	BOOL	zsw1
DCX_32_IP.I.Data[2].2	0		Decimal	BOOL	zsw1
DCX_32_IP.I.Data[2].3	0		Decimal	BOOL	zsw1
DCX_32_IP.I.Data[2].4	1		Decimal	BOOL	zsw1
DCX_32_IP.I.Data[2].5	0		Decimal	BOOL	zsw1
DCX_32_IP.I.Data[2].6	0		Decimal	BOOL	zsw1
DCX_32_IP.I.Data[2].7	0		Decimal	BOOL	zsw1
DCX_32_IP.I.Data[2].8	0		Decimal	BOOL	zsw1
DCX_32_IP.I.Data[2].9	0		Decimal	BOOL	zsw1
DCX_32_IP.I.Data[2].10	0		Decimal	BOOL	zsw1
DCX_32_IP.I.Data[2].11	0		Decimal	BOOL	zsw1
DCX_32_IP.I.Data[2].12	0		Decimal	BOOL	zsw1
DCX_32_IP.I.Data[2].13	0		Decimal	BOOL	zsw1
DCX_32_IP.I.Data[2].14	0		Decimal	BOOL	zsw1
DCX_32_IP.I.Data[2].15	0		Decimal	BOOL	zsw1

Figure 8.29 Status Word (Web Page Interface)

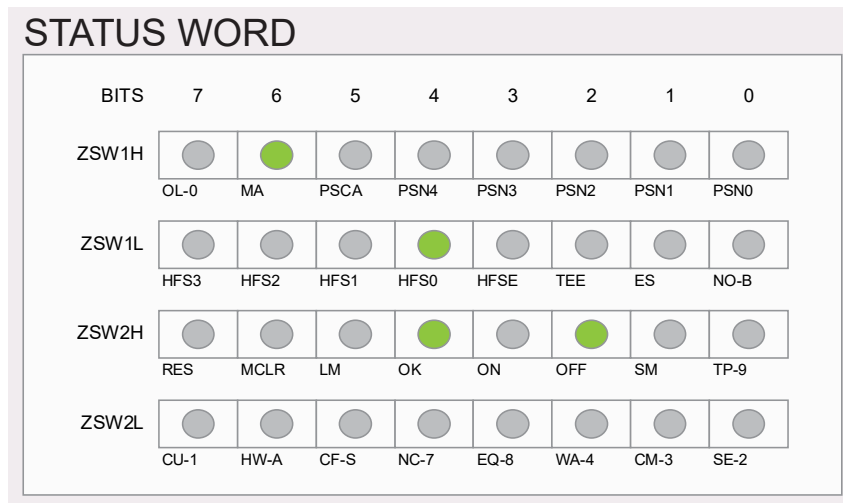

8.8.2 Live PLC Output Channel Example (DCX Control Word)

The following shows the PLC output channel expanded to bit level. The STW1 word "16384" is displayed at its binary level. Bit 14 (MA) = 1 is shown as being active on the Diagnostics Fieldbus section on the DCX Web Page Interface.

Figure 8.30 DCX Control Word

[_] DCX_32_IP.O	{...}	{...}		AB:ETHERNET_	
[_] DCX_32_IP.O.Data	{...}	{...}	Decimal	INT[20]	
[_] DCX_32_IP.O.Data[0]	16384		Decimal	INT	stw1
DCX_32_IP.O.Data[0].0	0		Decimal	BOOL	stw1
DCX_32_IP.O.Data[0].1	0		Decimal	BOOL	stw1
DCX_32_IP.O.Data[0].2	0		Decimal	BOOL	stw1
DCX_32_IP.O.Data[0].3	0		Decimal	BOOL	stw1
DCX_32_IP.O.Data[0].4	0		Decimal	BOOL	stw1
DCX_32_IP.O.Data[0].5	0		Decimal	BOOL	stw1
DCX_32_IP.O.Data[0].6	0		Decimal	BOOL	stw1
DCX_32_IP.O.Data[0].7	0		Decimal	BOOL	stw1
DCX_32_IP.O.Data[0].8	0		Decimal	BOOL	stw1
DCX_32_IP.O.Data[0].9	0		Decimal	BOOL	stw1
DCX_32_IP.O.Data[0].10	0		Decimal	BOOL	stw1
DCX_32_IP.O.Data[0].11	0		Decimal	BOOL	stw1
DCX_32_IP.O.Data[0].12	0		Decimal	BOOL	stw1
DCX_32_IP.O.Data[0].13	0		Decimal	BOOL	stw1
DCX_32_IP.O.Data[0].14	1		Decimal	BOOL	stw1
DCX_32_IP.O.Data[0].15	0		Decimal	BOOL	stw1

Figure 8.31 DCX Control Word (Web Page Interface)

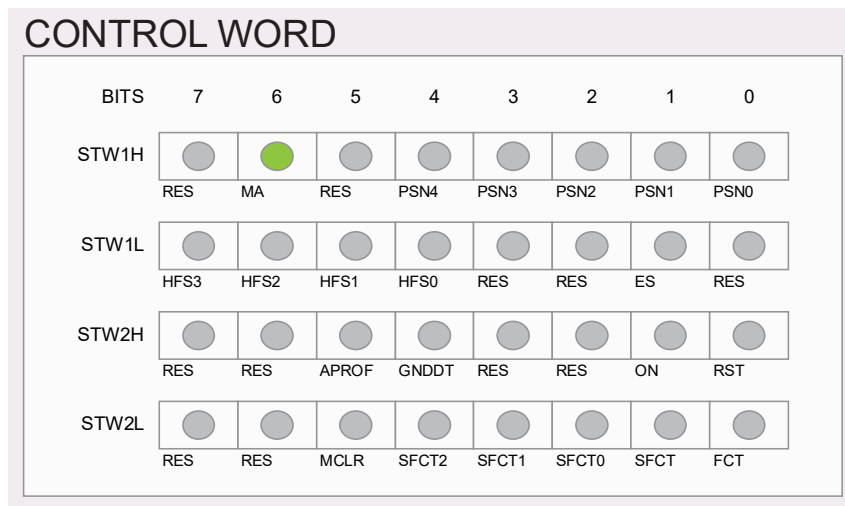





Chapter 9: Maintenance

9.1	General Maintenance Considerations	184
9.2	DCX F-EIP Power Supply Preventive Maintenance	186
9.3	Recommended Spare Stock	192
9.4	Circuit Diagram	198
9.5	Troubleshooting	199
9.6	Cold Start Procedure	202

9.1 General Maintenance Considerations

WARNING	High Voltage Hazard
	Power supplies produce high voltage. To avoid the possibility of an electrical shock, you should always power down your system prior to repairing any portion of it.

CAUTION	General Warning
	When performing maintenance on the welder, make sure that no other automated systems are active.

NOTICE	
	There are no customer replaceable components inside the power supply. Have all servicing done by a qualified Branson technician.

NOTICE	
	When returning printed circuit boards, make sure to enclose them in an anti-static package.

NOTICE	
	Connectors may not be keyed and wires may not be color-coded. Therefore, when disconnecting cables and wires, label them so you can reconnect them properly.

NOTICE



To prevent circuit damage from electrostatic discharge, always service the power supply on a static-dissipative surface, while wearing a properly grounded wrist strap.

NOTICE



When the battery is worn out, dispose it under the ordinance of each local government.

9.2 DCX F-EIP Power Supply Preventive Maintenance

The following preventive measures help assure long term operation of your Branson DCX F-EIP Power Supply equipment.

9.2.1 Periodically Clean the Equipment

NOTICE	
	Use only anti-static vacuum cleaners to prevent damage from electrostatic discharge to your power supply.

Air is continuously drawn into the power supply. Periodically disconnect the unit from power, remove the cover and vacuum out any accumulated dust and debris. Remove material adhering to:

- Power supply heat sink cooling fins
- Transformers
- Circuit boards
- Cooling intake vents
- Exhaust ports

External covers may be cleaned with a damp sponge or cloth using a solution of mild soap and water. Do not allow cleaning solution to enter the unit.

To prevent rust in areas of high humidity, exposed steel surfaces, may require a very light film of rust preventing oil, such as WD-40[®]*

* WD-40 is a registered trademark of WD-40 Manufacturing Company.

9.2.2 Recondition the Stack (Converter, Booster, and Horn)

NOTICE	
	<p>Never clean the converter-booster-horn stack mating surfaces by using a buffing wheel or by filing.</p>

Welding system components work most efficiently when the converter-booster-horn stack mating surfaces are flat, in solid contact, and free from fretting corrosion. Poor contact between mating surfaces wastes power output, makes tuning difficult, increases noise and heat, and may cause damage to the converter.

For standard 20 kHz and 30 kHz products, a Branson Mylar® polyester film washer should be installed between the horn and booster, and horn and converter. Replace the washer if torn or perforated. Stacks using Mylar® plastic film washers should be inspected every three months.

Stacks used with silicone grease, as with certain 20 kHz, 30 kHz and all 40 kHz products, should be periodically reconditioned to eliminate fretting corrosion. A stack using silicone grease should be inspected every two weeks for corrosion. When experience is gained for specific stacks, the inspection interval can be adjusted to a longer or shorter period as required.

Stack Reconditioning Procedure

To recondition stack mating surfaces, take the following steps:

Table 9.1 Stack Reconditioning Procedure

Step	Action
1	Disassemble the converter-booster-horn stack and wipe the mating surfaces with a clean cloth or paper towel.
2	Examine all mating surfaces. If any mating surface shows corrosion or a hard, dark deposit, recondition it.
3	If necessary, remove the threaded stud from the part.
4	Tape a clean sheet of #400 (or finer) grit emery cloth to a clean, smooth, flat surface (such as a sheet of plate glass), as in Figure 9.1 Reconditioning Stack Mating Surfaces .
5	Place the interface surface on the emery cloth. Grasp the part at the lower end, with your thumb over the spanner-wrench hole, and lap the part in a straight line across the emery cloth. Do not apply downward pressure — the weight of the part alone provides sufficient pressure.
6	Lap the part, two or three times, in the same direction against the emery cloth. (See Figure 9.1 Reconditioning Stack Mating Surfaces .)
7	Rotate the part 120 degrees, placing your thumb over the spanner-wrench hole, and repeat the lapping procedure in step 6.

Table 9.1 Stack Reconditioning Procedure

Step	Action
8	Rotate the part another 120 degrees to the next spanner-wrench hole, and repeat the lapping procedure in step 6.
9	Re-examine the mating surface. If necessary, repeat steps 2-5 until you remove most of the contaminant. Remember, this should not require more than two to three complete rotations for an aluminum horn or booster; a titanium component may require more rotations.
10	<p>Before re-inserting a threaded stud in an aluminum booster or horn: Using a file card or wire brush, clean any aluminum bits from the knurled end of the stud.</p> <p>Using a clean cloth or towel, clean the threaded hole.</p> <p>Examine the knurled end of the stud. If worn, replace the stud. Also, examine the stud and threaded hole for stripped threads.</p> <p>NOTICE Threaded studs cannot be reused in titanium horns or boosters. Replace all studs in these components.</p>
11	Assemble and install the stack.

Figure 9.1 Reconditioning Stack Mating Surfaces

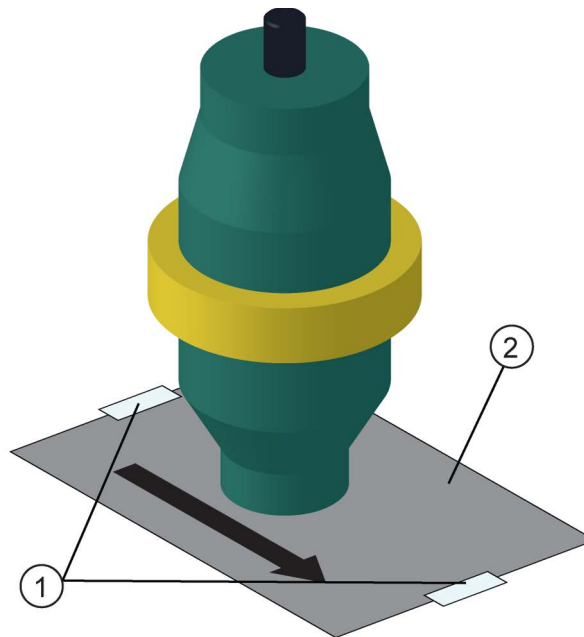

Table 9.2 Reconditioning Stack Mating Surfaces

Item	Description
1	Tape
2	#400 Emery Cloth

9.2.3 Stack Torque Values

Table 9.3 Stack Torque Values

Frequency	Torque
20 kHz	220 in·lb (25 N·m)
30 kHz	185 in·lb (21 N·m)
40 kHz	95 in·lb (11 N·m)

For a 20 kHz System

Table 9.4 Stack Reassembly for a 20 kHz System

Step	Action
1	Clean the mating surfaces of the converter, booster, and horn. Remove any foreign material from the threaded holes.
2	Install the threaded stud into the top of the booster. Torque to 450 in·lb (50.84 N·m). If the stud is dry, apply 1 or 2 drops of a light lubricating oil before installing.
3	Install the threaded stud into the top of the horn. Torque to 450 in·lb (50.84 N·m). If the stud is dry, apply 1 or 2 drops of a light lubricating oil before installing.
4	Install a single Mylar® plastic film washer (matching the size of the washer to the stud) to each interface.
5	Assemble the converter to the booster and the booster to the horn.
6	Torque to 220 in·lb (24.85 N·m) at each interface.

For a 30 kHz System

Table 9.5 Stack Reassembly for a 30 kHz System

Step	Action
1	Clean the mating surfaces of the converter, booster, and horn. Remove any foreign material from the threaded holes.
2	Install the threaded stud into the top of the booster. Torque to 290 in·lb (32.76 N·m). If the stud is dry, apply 1 or 2 drops of a light lubricating oil before installing.
3	Install the threaded stud into the top of the horn. Torque to 290 in·lb (32.76 N·m). If the stud is dry, apply 1 or 2 drops of a light lubricating oil before installing.
4	Install a single Mylar® plastic film washer (matching the size of the washer to the stud) to each interface.
5	Assemble the converter to the booster and the booster to the horn.
6	Torque to 185 in·lb (21 N·m) at each interface.

For a 40 kHz System

Table 9.6 Stack Reassembly for a 40 kHz System

Step	Action
1	Clean the mating surfaces of the converter, booster, and horn. Remove any foreign material from the threaded holes.
2	Apply a drop of Loctite®* 290 threadlocker (or equivalent) to the studs for the booster and horn.
3	Install the threaded stud into the top of the booster. Torque to 70 in·lb (7.91 N·m). Remove excess Loctite 290 threadlocker from the booster face and let cure for 30 minutes.
4	Install the threaded stud into the top of the horn. Torque to 70 in·lb (7.91 N·m). Remove excess Loctite 290 threadlocker from the horn face and let cure for 30 minutes.
5	Coat each interface surface with a thin film of silicon grease - but do not apply silicon grease to a threaded stud or tip.
6	Torque to 95 in·lb (10.73 N·m) at each interface.

* Loctite is a registered trademark of Henkel Corporation, U.S.A.

9.2.4 Stud Torque Values

Table 9.7 Stud Torque Values

Used on	Stud Size	Torque	EDP #
20 kHz	1/2 in x 20 x 1-1/4 in	450 in·lb, 50.84 N·m	100-098-370
	1/2 in x 20 x 1-1/2 in		100-098-123
30 kHz	3/8 in x 24 x 1 in	290 in·lb, 32.76 N·m	100-298-170R
40 kHz*	M8X1.25 X 20 (40 kHz horns and boosters)	70 in·lb, 7.91 N·m	100-098-790

* Add a drop of Loctite 290 threadlocker to the stud. Torque and let cure for 30 minutes before using.

9.3 Recommended Spare Stock

This section provides lists of replacement parts, system cables, and suggested spares.

9.3.1 System Cables

You can order the following cables:

Table 9.8 DCX F-EIP Power Supply System Cables

P/N	Description
100-240-383	Cable, RF 8 ft (2.5 m)
100-240-384	Cable, RF 15 ft (4.5 m)
100-240-385	Cable, RF 25 ft (7.5 m)
100-240-387	Cable, RF right angle 8 ft (2.5 m)
100-240-388	Cable, RF right angle 15 ft (4.5 m)
100-240-389	Cable, RF right angle 25 ft (7.5 m)
100-240-392	Cable, User I/O 25 ft (7.5 m)
100-240-393	Cable, User I/O 50 ft (15 m)
200-240-396	Cable Ethernet Cat 5e 7 ft (2.1 m)

9.3.2 Suggested Spares

Table 9.9 Suggested Spares

Description	EDP#	1-4 Units	6-12 Units	14+ Units
Converter	Refer to Table 9.10 Converters Compatible with the DCX F-EIP Power Supply.	0	1	2
Booster	Refer to Table 9.11 DCX F-EIP Power Supply Compatible Boosters.	0	1	2
Horn	As Ordered	1	1	2
Studs	Refer to Table 9.12 Other Items used with the DCX F-EIP Power Supply.	4	6	8
Mylar [®] Plastic Film Washer Kit	Refer to Table 9.12 Other Items used with the DCX F-EIP Power Supply.	1	1	1

9.3.3 Converters Compatible with the DCX F-EIP Power Supply

Table 9.10 Converters Compatible with the DCX F-EIP Power Supply

Where used	Model	Connector	Part Number
20 kHz / 1250 W 20 kHz / 2500 W 20 kHz / 4000 W	CR-20S	SHV connector	125-135-115R
	CR-20C	SHV connector with 3 ft (0.9 m) cable	159-135-210R
	CH-20S (932 AH SPL)	SHV connector	159-135-075R
	CH-20C	SHV connector with 3 ft (0.9 m) cable	159-135-211R
	CS-20S	SHV connector	159-135-138R
	CS-20C	SHV connector with 3 ft (0.9 m) cable	159-135-209R
30 kHz / 1500 W	CR-30S	SHV connectors	101-135-081R
	CR-30C	SHV connector with 3 ft (0.9 m) cable	159-135-213R
	CH-30S	SHV connector	101-135-071R
	CH-30C	SHV connector with 3 ft (0.9 m) cable	159-135-214R
	CS-30S	SHV connector	159-135-110R
	CS-30C	SHV connector with 3 ft (0.9 m) cable	159-135-212R
40 kHz / 800 W	4TP	SHV connector (platen mount)	101-135-068R
	CR-40S (4TH)	SHV connector	101-135-067R
	CR-40C	SHV connector with 3 ft (0.9 m) cable	159-135-215R

9.3.4 DCX F-EIP Power Supply Compatible Boosters

Table 9.11 DCX F-EIP Power Supply Compatible Boosters

Type of Booster	Description	Part Number
Solid Mount (1/2-20 horn stud) 20 kHz	Titanium, 1:0.6 (Purple)	101-149-095
	Titanium, 1:1 (Green)	101-149-096
	Titanium, 1:1.5 (Gold)	101-149-097
	Titanium, 1:2 (Silver)	101-149-098
	Titanium, 1:2.5 (Black)	101-149-099
Solid Mount (M8 x 1.25 horn stud) 40 kHz	Titanium, 1:0.6 (Purple)	109-041-178
	Titanium, 1:1 (Green)	109-041-177
	Titanium, 1:1.5 (Gold)	109-041-176
	Titanium, 1:2 (Silver)	109-041-175
	Titanium, 1:2.5 (Black)	109-041-174
Standard Series (1/2-20 horn stud) 20 kHz	Aluminum, 1:0.6 (Purple)	101-149-055
	Aluminum, 1:1 (Green)	101-149-051
	Aluminum, 1:1.5 (Gold)	101-149-052
	Aluminum, 1:2 (Silver)	101-149-053
	Titanium, 1:0.6 (Purple)	101-149-060
	Titanium, 1:1 (Green)	101-149-056
	Titanium, 1:1.5 (Gold)	101-149-057
	Titanium, 1:2 (Silver)	101-149-058
Standard Series (3/8-24 horn stud) 30 kHz	Titanium, 1:2.5 (Black)	101-149-103
	Titanium, 1:2 (Silver)	101-149-104
	Titanium, 1:1.5 (Gold)	101-149-105
	Titanium, 1:1 (Green)	101-149-106

Table 9.11 DCX F-EIP Power Supply Compatible Boosters

Type of Booster	Description	Part Number
Standard Series (M8 x 1.25 horn stud) 40 kHz	Aluminum, 1:0.6 (Purple)	101-149-087
	Aluminum, 1:1 (Green)	101-149-079
	Aluminum, 1:1.5 (Gold)	101-149-080
	Aluminum, 1:2 (Silver)	101-149-081R
	Aluminum, 1:2.5 (Black)	101-149-082
	Titanium, 1:1 (Green)	101-149-085
	Titanium, 1:1.5 (Gold)	101-149-086
	Titanium, 1:2 (Silver)	101-149-083
	Titanium, 1:2.5 (Black)	101-149-084

9.3.5 Other Items used with the DCX F-EIP Power Supply

Table 9.12 Other Items used with the DCX F-EIP Power Supply

Product	Description	Part No.
Silicone grease	For use with 40 kHz systems	101-053-002
Mylar® Plastic Film Washers (for 20 kHz systems)	Kit, 10 each (1/2 in. and 3/8 in.)	100-063-357
	Kit, 150 each (1/2 in.)	100-063-471
	Kit, 150 each (3/8 in.)	100-063-472
Mylar® Plastic Film Washers (for 30 kHz systems)	Kit, 10 each (3/8 in.)	100-063-632
	Kit, 150 each (3/8 in.)	100-063-712
Tool Kit	20 kHz (spanner wrench and 10 pc washer kit)	101-063-208R
	30 kHz (spanner wrench and 10 pc washer kit)	101-063-636R
	40 kHz (spanner wrench and silicone grease)	101-063-176R
Spanner wrench	20 kHz	101-118-039
	30 kHz	201-118-033
	40 kHz	201-118-024
Studs	1/2-20 x 1-1/4 (titanium horns)	100-098-370
	1/2-20 x 1-1/2 (aluminum horns, 20 kHz boosters)	100-098-123
	3/8-24 x 1 (30 kHz titanium horns and boosters)	100-298-170R
	M8X1.25 X 20 (40 kHz horns and boosters)	100-098-790

9.4 Circuit Diagram

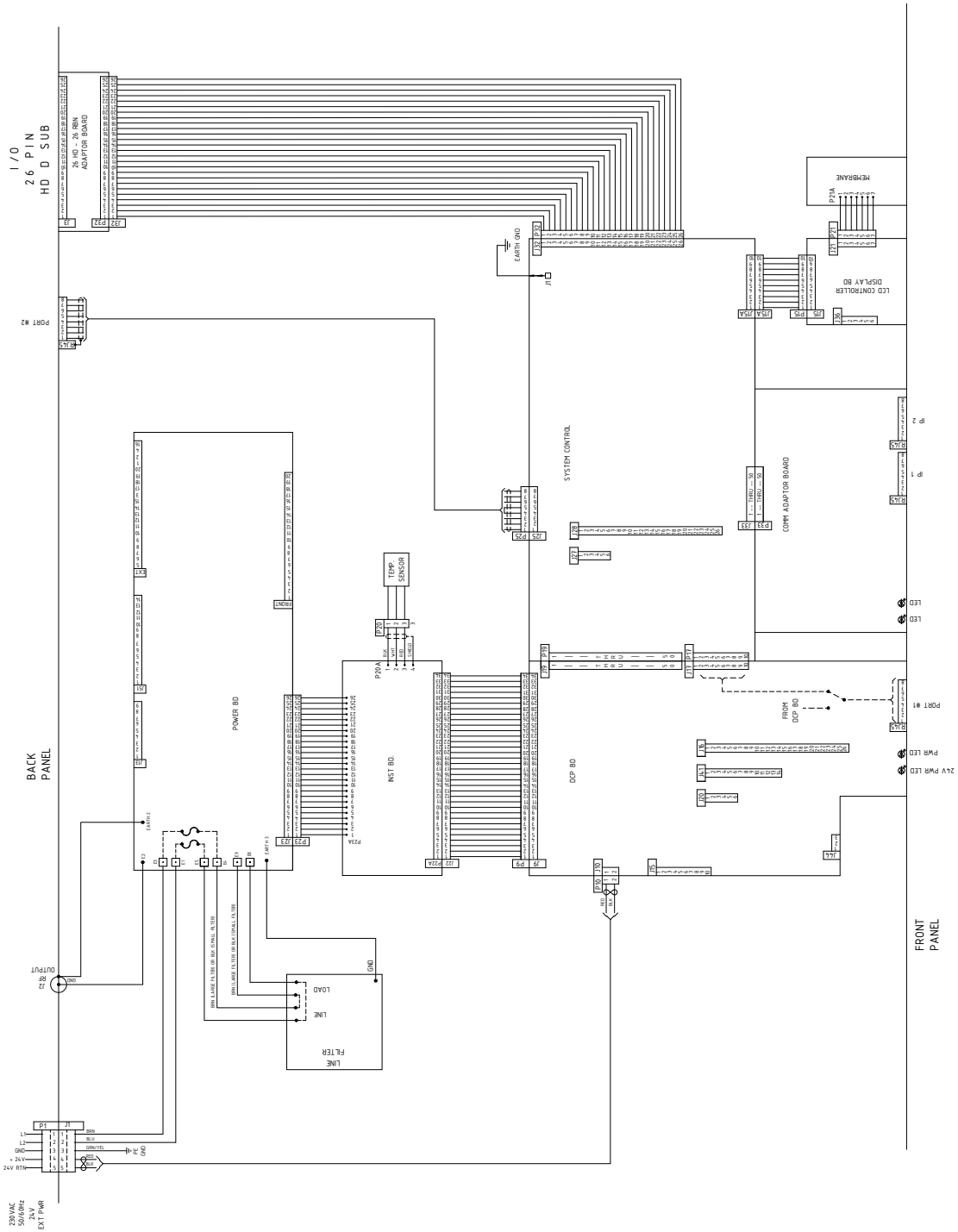

9.5 Troubleshooting

If you have a problem operating the DCX F-EIP Power Supply, take the following steps:

Table 9.13 Troubleshooting

Step	Action
1	Make sure the converter-booster-horn stack is properly assembled and installed.
2	For instructions on reconditioning stack component surfaces, refer to 9.2.2 Recondition the Stack (Converter, Booster, and Horn) .
3	If you need additional help, call your local Branson representative, refer to 1.3 How to Contact Branson .

NOTICE	
	DCX F-EIP Power Supply should be serviced only by qualified technicians using Branson-approved test and repair equipment, repair procedures, and replacement parts. Unauthorized attempts at repair or modification of the power supply will void the warranty.

9.5.1 Common Electrical Problems

Table 9.14 Troubleshooting Common Electrical Problems

Problem	Check	Solution
When touching a component of the weld system, you get a slight electrical shock.	Ensure the ground cable is connected properly.	N/A
	Inspect the line cables.	If failed, repair or replace.

9.5.2 Ultrasonic Power Problems

Table 9.15 Troubleshooting Ultrasonic Power Problems

Problem	Check	Solution
Ultrasonic power delivered to horn; no indication on bar graph.	Check connector cables, replace if failed.	Replace defective cables.
	Test power supply.	See 7.8 Ultrasonics Test Procedure .
No ultrasonic power generated when Test key pressed; no Alarm indicator.	Failed or missing stack.	Replace.
	RF cable unplugged or failed; replace if failed.	Plug in or replace.
	Test power supply (7.8 Ultrasonics Test Procedure).	If defective, send unit for repair.
Unable to adjust amplitude using the front panel keypad.	Register setting configured to "External Amplitude Control"	Reset if required. See 7.5 Configuring the Power Supply Registers .
Unable to remote control.	User fieldbus or I/O cabling	Repair or replace.
	Customer's switching device	Test/inspect/repair/replace.

9.5.3 Weld Cycle Problems

Table 9.16 Troubleshooting Weld Cycle Problems

Problem	Check	Solution
Full ultrasonic power not delivered.	Unsuitable horn or booster selection.	Contact Branson Applications Lab
	Plastic part material varies.	
	Mold release lubricant in weld area.	
	Unsuitable joint design.	
	Unsuitable or misaligned part fixture.	
	Amplitude setting	Adjust if required.
No ultrasonic power passed to horn.	Power supply overheating.	If defective, send unit for repair.
Alarm indicator illuminates when you press the Test key or during the weld cycle.	Check converter-booster-horn stack interface for fretting corrosion.	See 9.2.2 Recondition the Stack (Converter, Booster, and Horn) .
	Check for loose or failed horn converter or booster.	Tighten or replace as needed.
	Check for loose or failed horn or booster stud.	
	Failed RF cable	Replace if failed.
Excessively warm horn, booster, and converter; occasional overloads.	Check converter-booster-horn stack mating surfaces for fretting corrosion.	See 9.2.2 Recondition the Stack (Converter, Booster, and Horn) .
	Be certain proper cooling has been provided.	If defective, send unit for repair.

9.6 Cold Start Procedure

The power supply internal memory stores the system default settings and the registers that you set. It also provides temporary storage to support the power supply internal functions. A cold start clears and restores all the power supply settings back to the original factory defaults. It is not necessary to perform a cold start during normal operation and servicing, but you might find a cold start helpful when:

- You suspect the system is not operating properly
- You want to make a new setup
- Some system memory registers, such as Software version, will not be cleared by this Cold Start procedure

9.6.1 Performing a Cold Start

NOTICE	
	<p>Using the Cold Start procedure will erase the current Amplitude Setting, the IP address and some of the Registers that you set. Be sure you have a record of your setup if you want to retain it or use the system backup feature from the DCX F-EIP Power Supply Web Page Interface.</p>

Table 9.17 Steps to Perform a Cold Start

Step	Action
1	Turn off the power supply.
2	Connect together pins 4 and 10 on the 26-pin User I/O Connector.
3	Turn on the power supply.
4	After the power up sequence ends, turn off the power supply.
5	Disconnect pins 4 and 10 of the 26-pin on User I/O Connector.

Appendix A: Alarms

A.1	Overload Alarms (Group 0)	204
A.2	Cutoff Alarms (Group 1)	206
A.3	Setup Alarms (Group 2)	207
A.4	Cycle Modified Alarms (Group 3)	208
A.5	Warning Alarms (Group 4)	209
A.6	Limit Alarms (Group 5)	210
A.7	Equipment Failure Alarms (Group 6)	211
A.8	No Cycle Alarms (Group 7)	213
A.9	Communication Failure Alarms (Group 8)	214
A.10	Hardware Alarms (Group A)	215
A.11	Non-Cycle Overload Alarms (Group B)	216
A.12	EIP Standard Error Codes	218

A.1 Overload Alarms (Group 0)

This group includes all overload alarms that can occur during a weld cycle. This overload group will abort the weld cycle after stopping the sonics.

Table A.1 Overload Alarms (Group 0)

LCD Alarm Code	Fieldbus Bit Assignment	Alarm	Description
E0:01	Bit01	Weld Overload - Phase	This alarm is generated in case of weld phase is out of weld phase limit for weld phase limit time period.
E0:02	Bit02	Weld Overload - Current	This alarm is generated in case of weld current reaches to peak RF current limit of the system.
E0:03	Bit03	Weld Overload - Frequency	This alarm is generated in case of weld frequency is out of weld frequency low and high limit window.
E0:04	Bit04	Weld Overload - Power	This alarm is generated in case of weld power reaches to peak RF power limit of the system.
E0:05	Bit05	Weld Overload - Voltage	This alarm is generated in case of voltage during weld reaches to peak RF voltage limit of the system.
E0:06	Bit06	Weld Overload - Temperature	This alarm is generated in case of temperature inside the system (at the heat sink) reaches to 85° C (±5° C). NOTICE Alarm cannot be cleared until the temperature returns below threshold.
E0:11	Bit17	Energy Brake Overload - Phase	This alarm is generated in case of phase is out of weld phase limit for weld phase limit time period during energy breaking.
E0:12	Bit18	Energy Brake Overload - Current	This alarm is generated in case of weld current reaches to peak RF current limit of the system during energy breaking.
E0:13	Bit19	Energy Brake Overload - Frequency	This alarm is generated in case of weld frequency is out of weld frequency low and high limit window during energy breaking.

Table A.1 Overload Alarms (Group 0)

LCD Alarm Code	Fieldbus Bit Assignment	Alarm	Description
E0:14	Bit20	Energy Brake Overload - Power	This alarm is generated in case of weld power reaches to peak RF power limit of the system during energy breaking.
E0:15	Bit21	Energy Brake Overload - Voltage	This alarm is generated in case of voltage during weld reaches to peak RF voltage limit of the system during energy breaking.
E0:16	Bit22	Energy Brake Overload - Temperature	<p>This alarm is generated in case of temperature inside the system (at the heat sink) reaches to 85° C ($\pm 5^\circ$ C) during energy breaking.</p> <p>NOTICE Alarm cannot be cleared until the temperature returns below threshold.</p>

A.2 Cutoff Alarms (Group 1)

This groups includes all cutoff alarms. Cutoff alarms are defined as a limit on a parameter, that when exceeded, will stop ultrasonics. The remaining portion of a weld cycle will continue.

Table A.2 Cutoff Alarms (Group 1)

LCD Alarm Code	Fieldbus Bit Assignment	Alarm	Description
E1:02	Bit02	Energy Cutoff	Energy cutoff alarm is generated if the energy value during sonics on exceeded to the set cutoff value during a weld.
E1:03	Bit03	Power Cutoff	Power cutoff alarm is generated if the peak power value during sonics on exceeded to the set cutoff value.
E1:04	Bit04	Custom Input1 Cutoff	User can configure one of the user analog input as a Custom Input1 and also set a cutoff value from that input. System will generate custom Input1 Cutoff alarm if the user input voltage exceeds from the cutoff value set by user.
E1:05	Bit05	Time Cutoff (Maximum Time-out)	User can set a time cutoff for weld and the alarm will be generated if the sonic on time during weld exceeds to the set value.
E1:06	Bit06	Frequency Low Cutoff	User can set frequency low cutoff (negative offset to be applied from weld start frequency) for weld and the alarm will be generated if the frequency during weld goes below to the weld start frequency minus set value.
E1:07	Bit07	Frequency High Cutoff	User can set frequency high cutoff (positive offset to be applied from weld start frequency) for weld and the alarm will be generated if the frequency during weld goes above to the weld start frequency plus set value.
E1:08	Bit08	Custom Input2 Cutoff	User can configure one of the user analog input as a Custom Input2 and also set a cutoff value from that input. System will generate Custom Input2 cutoff alarm if the user input voltage exceeds from the cutoff value set by user.

A.3 Setup Alarms (Group 2)

This group includes all alarms that can occur during setup.

Table A.3 Setup Alarms (Group 2)

LCD Alarm Code	Fieldbus Bit Assignment	Alarm	Description
E2:03	Bit02	Invalid Preset	Recalling invalid preset. Preset > 32.

A.4 Cycle Modified Alarms (Group 3)

Cycle modified alarms cause the cycle to be modified from the intended parameters. This can be caused by the user or equipment conditions changing. This group of alarms will always abort the cycle.

Table A.4 Cycle Modified Alarms (Group 3)

LCD Alarm Code	Fieldbus Bit Assignment	Alarm	Description
E3:01	Bit01	Trigger Lost During Weld Or Hold	This alarm is generated during a weld cycle in case actuator is present and trigger input is lost before completing the weld (in case of time, energy, peak power and ground detect mode).
E3:02	Bit02	Cycle Aborted Via User I/O	This alarm is generated if user aborts the cycle using cycle abort user input.

A.5 Warning Alarms (Group 4)

Warnings occur when a condition is happening that may have been unexpected. This group of alarms does not abort the cycle. This group includes overloads during afterburst because they do not abort the cycle.

Table A.5 Warning Alarms (Group 4)

LCD Alarm Code	Fieldbus Bit Assignment	Alarm	Description
E4:04	Bit04	Amplitude Step Not Reached	This alarm is generated if Amplitude Stepping is ON but weld cycle finishes before stepping take places.
E4:05	Bit05	Sonics Disabled Via User I/O	This alarm indicates the user has enabled an input pin as "Sonics Disable" and has run a cycle with this input active.
E4:11	Bit17	Afterburst Overload - Phase	This alarm is generated in case of afterburst phase is out of Weld Phase limit for Weld Phase limit time period.
E4:12	Bit18	Afterburst Overload - Current	This Alarm is generated in case of weld current reaches to peak RF current limit of the system during afterburst.
E4:13	Bit19	Afterburst Overload - Frequency	This alarm is generated in case of Weld Frequency is out of Weld Frequency Low and High limit window during afterburst.
E4:14	Bit20	Afterburst Overload - Power	This alarm is generated in case of weld power reaches to peak RF power limit of the system during afterburst.
E4:15	Bit21	Afterburst Overload - Voltage	This alarm is generated in case of weld voltage reaches to peak RF voltage limit of the system during afterburst.
E4:16	Bit22	Afterburst Overload - Temperature	The internal heat sink temperature is greater than allowed. NOTICE Alarm cannot be cleared until the temperature returns below threshold.

A.6 Limit Alarms (Group 5)

Limits will be reported at the end of the weld, but, unlike cutoffs, will not stop the sonics or abort the cycle.

Table A.6 Limit Alarms (Group 5)

LCD Alarm Code	Fieldbus Bit Assignment	Alarm	Description
E5:03	Bit03	Power - Minus Limit	This alarm is generated at the end of the cycle in case of Weld peak power is lower than the Power Minus limit.
E5:04	Bit04	Power - Plus Limit	This alarm is generated at the end of the cycle in case of Weld peak power is bigger than the Power Plus limit.
E5:05	Bit05	Time - Minus Limit	This alarm is generated at the end of the cycle in case of Weld time is lower than the Time Minus limit.
E5:06	Bit06	Time - Plus Limit	This alarm is generated at the end of the cycle in case of Weld time is bigger than the time Plus limit.
E5:07	Bit07	Energy - Minus Limit	This alarm is generated at the end of the cycle in case of Weld energy is lower than the energy Minus limit.
E5:08	Bit08	Energy - Plus Limit	This alarm is generated at the end of the cycle in case of Weld energy is bigger than the energy Plus limit.

A.7 Equipment Failure Alarms (Group 6)

Equipment alarms are caused by user equipment malfunction. These alarms occur before a cycle starts and therefore, will prevent a cycle from starting until the malfunction is corrected.

NOTICE	
	Alarm message will not reset until the malfunction is corrected.

Table A.7 Equipment Failure Alarms (Group 6)

LCD Alarm Code	Fieldbus Bit Assignment	Alarm	Description
E6:01	Bit01	Start Input Still Active	This alarm is generated if External Start/Cycle Start/Trigger signal is active for more than 4 seconds after finishing the weld or while system is waiting to come into ready state.
E6:02	Bit02	Trigger Active While ULS Active	This alarm is generated any time if Trigger and ULS both becomes active.
E6:03	Bit03	Trigger Active In Ready	This alarm is generated if Trigger signal becomes active while system is in ready state and actuator is present.
E6:04	Bit04	ULS Not Active In Ready	This alarm is generated if actuator is present and ULS is not active while system is already in ready state.
E6:05	Bit05	Ground Detect Active In Ready	This alarm is generated if ground detect signal becomes active while system is in ready state.
E6:07	Bit07	Cable Failure - User I/O	The cable detect user I/O feature has been enabled and detected that the assigned pin does not have the voltage applied.
E6:08	Bit08	Field Bus Removed	Communication between the internal field bus card and the internal weld controller has failed.
E6:09	Bit09	Start Input Lost	This alarm is generated when source of cycle start is removed before Trigger comes.

Table A.7 Equipment Failure Alarms (Group 6)

LCD Alarm Code	Fieldbus Bit Assignment	Alarm	Description
E6:10	Bit16	Cycle Abort In Ready	This alarm is generated if Cycle Abort signal becomes active while system is in ready state.
E6:11	Bit17	ULS Time Out	This alarm is generated if Actuator is present and ULS does not become active with a time-out at the end of the cycle.
E6:12	Bit18	ULS Active During Weld	This alarm is generated if System is waiting for TRS and ULS becomes active. After TRS is active and system jumps to next state of cycle this alarm is generated when ULS becomes active during cycle along with "TRS active while ULS Active" alarm.

A.8 No Cycle Alarms (Group 7)

No cycle alarms are caused by possible mechanical setup errors or user errors. These are usually time out errors because an expected input did not occur in time. They will prevent a cycle from continuing. So although a cycle may have started, the cycle will be aborted.

Table A.8 No Cycle Alarms (Group 7)

LCD Alarm Code	Fieldbus Bit Assignment	Alarm	Description
E7:01	Bit01	ULS Time-Out (Start Of Cycle)	A cycle start has been received but the upper limit switch has not gone inactive within the time-out specified by the system.
E7:02	Bit02	Trigger Time-Out	A cycle has been started, but the trigger input has not gone active within the time-out specified by the system.
E7:03	Bit03	External Sonics Delay Time-Out (User I/O)	The system is waiting for an external user defined input (if configured), but has not received the input within the time-out specified by the system.
E7:04	Bit04	Interlock Not In Place (User I/O)	The system is waiting for a valid status from a user defined Interlock input (if configured), but the input is not active at the time of Cycle start.
E7:05	Bit05	RF Switch Feedback Failure	A feedback signal from the RF switch not was not received within the time specified by the user.
E7:06	Bit06	Part Not In Place (User I/O)	The system is waiting for an external user defined input, but the input is not active at the Cycle Start.
E7:07	Bit07	Stack Number Not Valid For RF Switching	An invalid horn number is being requested from the preset. Any values outside the range of 16 horn numbers will cause an alarm.

A.9 Communication Failure Alarms (Group 8)

This group handles any communication issue that occur between processors. This is generally the result of noisy environments or other conditions that interrupt communications. Physical cable failures will be included in the Hardware Failure group. Because data cannot be transmitted between internal hardware, the cycle will be aborted.

NOTICE	
	Alarm message will not reset until the malfunction is corrected.

Table A.9 Communication Failure Alarms (Group 8)

LCD Alarm Code	Fieldbus Bit Assignment	Alarm	Description
E8:01	Bit01	Modbus Communication Failure	Internal communication failure.
E8:02	Bit02	LCD Communication Failure	Communication between the LCD user interface and the internal weld controller has failed.
E8:03	Bit03	Fieldbus Communication Failure	The field bus was detected at power on, but is no longer responding. Either the cable has been removed or the field bus master has stop working. If the system is powered down and field bus is not detected at power up, then the system can still be used without the field bus.

A.10 Hardware Alarms (Group A)

This group of alarms will deal with internal equipment failures. This will generally be equipment that is supplied by Branson as part in the internal workings of the power supply. Cycles cannot be started if there is a Hardware alarm. If a cycle is in process when the alarm is detected then the cycle is aborted.

NOTICE	
	Alarm message will not reset until the malfunction is corrected.

Table A.10 Hardware Alarms (Group A)

LCD Alarm Code	Fieldbus Bit Assignment	Alarm	Description
EA:01	Bit01	LCD NOVRAM Failure	LCD NOVRAM is not working.
EA:02	Bit02	FRAM or NOVRAM Failure	FRAM or NOVRAM is not working.
EA:03	Bit03	SD RAM Failure	SD RAM is now working.
EA:04	Bit04	Connection Failure - WC to LCD	The physical connection between the WC board and LCD board is missing or broken.
EA:05	Bit05	Connection Failure - WC to DCP	The physical connection between the WC board and DCP board is missing or broken.
EA:06	Bit06	AC Line Voltage Lost	The AC line voltage to the system is lost but the 24 V supply is still present. ES bit activated, check ZSW1 Low Byte.

A.11 Non-Cycle Overload Alarms (Group B)

This group deals with overloads that occur outside of a weld cycle. By definition a weld is not in process so the weld cycle counter is not affected and the weld is not aborted.

Table A.11 Non-Cycle Overload Alarms (Group B)

LCD Alarm Code	Fieldbus Bit Assignment	Alarm	Description
Eb:01	Bit01	Seek Overload - Phase	This alarm is generated in case of phase during Seek reaches to peak RF phase limit of the system.
Eb:02	Bit02	Seek Overload - Current	This alarm is generated in case of current during Seek reaches to peak RF current limit of the system.
Eb:03	Bit03	Seek Overload - Frequency	This alarm is generated in case of Frequency during seek is out of Seek Frequency Low and High limit window.
Eb:04	Bit04	Seek Overload - Power	This alarm is generated in case of Power during seek reaches to peak RF Power limit of the system.
Eb:05	Bit05	Seek Overload - Voltage	This alarm is generated in case of Voltage during seek reaches to peak RF voltage limit of the system.
Eb:06	Bit06	Seek Overload - Temperature	This alarm is generated in case of temperature inside the system (at the heat sink) reaches to 85° C ($\pm 5^{\circ}$ C) during Seek. NOTICE Alarm cannot be cleared until the temperature returns below threshold.
Eb:11	Bit17	Test Overload - Phase	This alarm is generated in case of phase during Test reaches to peak RF phase limit of the system.
Eb:12	Bit18	Test Overload - Current	This alarm is generated in case of current during Test reaches to peak RF current limit of the system.
Eb:13	Bit19	Test Overload - Frequency	This alarm is generated in case of Frequency during seek is out of Test Frequency Low and High limit window.

Table A.11 Non-Cycle Overload Alarms (Group B)

LCD Alarm Code	Fieldbus Bit Assignment	Alarm	Description
Eb:14	Bit20	Test Overload - Power	This alarm is generated in case of Power during Test reaches to peak RF Power limit of the system.
Eb:15	Bit21	Test Overload - Voltage	This Alarm is generated in case of Voltage during Test reaches to peak RF voltage limit of the system.
Eb:16	Bit22	Test Overload - Temperature	<p>This alarm is generated in case of temperature inside the system (at the heat sink) reaches to 85° C ($\pm 5^\circ$ C) during Test.</p> <p>NOTICE Alarm cannot be cleared until the temperature returns below threshold.</p>

A.12 EIP Standard Error Codes

Table A.12 EIP Standard Error Codes

CIP Status		Status Name	Alarm Text
Dec	Hex		
0		Success	Service was successfully performed by the object specified.
3	0x03	Invalid parameter value	A parameter associated with the request was invalid. This code is used when a parameter does not meet the requirements of this specification and/or the requirements defined in an Application Object Specification.
5	0x05	Path destination unknown	The path segment identifier or the segment syntax was not understood by the processing node. Path processing shall, stop when a path segment error is encountered.
8	0x08	Service not supported	The requested service was not implemented or was not defined for this Object Class/ Instance.
9	0x09	Invalid attribute value	Invalid attribute data detected.
14	0x0E	Attribute not settable	A request to modify a non-modifiable attribute was received.
15	0x0F	Privilege violation	A permission/privilege check failed. The Token has not been obtained.
31	0x1E	Vendor specific error	A vendor specific error has been encountered. The additional Code Field of the Error Response defines the particular error encountered. Use of this General Error Code should only be performed when none of the Error Codes presented in this table or within an Object Class definition accurately reflect the error.

NOTICE	
	<p>These error codes are visible on the Diagnostics – Fieldbus Test web page on an EIP unit in the CIP Status box. Before reading the code click on the Update button to ensure you have the latest status code.</p>

Appendix B: EtherNet/IP Commands

B.1	Parameter Set Class 100 (32 Instances)	220
B.2	Weld Data Class 101 (32 Instances)	223
B.3	Stack Parameter Class 102 (16 Instances)	225
B.4	Common Stack Parameters (16 instances)	226
B.5	Stack Status Class 103 (16 Instances)	227
B.6	Alarm Data Class 104 (1 Instances)	229
B.7	System Information Class 105 (1 Instances)	230
B.8	Other Information Class 112 (1 Instances)	231
B.9	Identity Class 1 (1 Instance)	232

B.1 Parameter Set Class 100 (32 Instances)

Each instance refers to the preset number.

Table B.1 Parameter Set Class

Attribute ID	Name	Data Type	Access	Default	Min.	Max.	Format	Unit
1010	Preset Name (Character 1)	AINT8	Get/Set	64	32	128	-	-
1011	Preset Name (Character 2)	AINT8	Get/Set	64	32	128	-	-
1012	Preset Name (Character 3)	AINT8	Get/Set	64	32	128	-	-
1013	Preset Name (Character 4)	AINT8	Get/Set	64	32	128	-	-
1014	Preset Name (Character 5)	AINT8	Get/Set	64	32	128	-	-
1015	Preset Name (Character 6)	AINT8	Get/Set	64	32	128	-	-
1016	Preset Name (Character 7)	AINT8	Get/Set	64	32	128	-	-
1017	Preset Name (Character 8)	AINT8	Get/Set	64	32	128	-	-
1018	Preset Name (Character 9)	AINT8	Get/Set	64	32	128	-	-
1019	Preset Name (Character 10)	AINT8	Get/Set	64	32	128	-	-
1020	Preset Name (Character 11)	AINT8	Get/Set	64	32	128	-	-
1021	Preset Name (Character 12)	AINT8	Get/Set	64	32	128	-	-
1022	Preset Name (Character 13)	AINT8	Get/Set	64	32	128	-	-
1023	Preset Name (Character 14)	AINT8	Get/Set	64	32	128	-	-
1024	Preset Name (Character 15)	AINT8	Get/Set	64	32	128	-	-
1025	Preset Name (Character 16)	AINT8	Get/Set	64	32	128	-	-
1026	Preset Name (Character 17)	AINT8	Get/Set	64	32	128	-	-
1027	Preset Name (Character 18)	AINT8	Get/Set	64	32	128	-	-
1028	Preset Name (Character 19)	AINT8	Get/Set	64	32	128	-	-
1029	Preset Name (Character 20)	AINT8	Get/Set	64	32	128	-	-
1040	Horn number assigned to a preset	AUINT8	Get/Set	0	0	15	-	-
1060	Weld Mode (0=Continuous, 1=Time, 2=Energy, 3=Peak Power, 4=Ground Detect)	AINT32	Get/Set	0	0	4		
1061	Time	AINT32	Get/Set	10	10	30000		ms
1062	Energy (Value should be entered 10 times higher)	AINT32	Get/Set	10	1	99990		0.1xJ
1063	Peak Power	AINT32	Get/Set	1	1	100		%
1064	Ground Detect Time	AINT32	Get/Set	1	0	500		ms
1065	Amplitude A	AINT32	Get/Set	100	10	100		%
1066	Amplitude B	AINT32	Get/Set	100	10	100		%
1067	Amplitude Profile Criterion (0=Fix, 1=External analog in, 2=Step@Time, 3=Step@Energy, 4=Step@Power, 5=Step@External)	AINT32	Get/Set	0	0	5	Selection	-
1068	Amplitude Profile Time	AINT32	Get/Set	10	1	30000		ms

Table B.1 Parameter Set Class

Attribute ID	Name	Data Type	Access	Default	Min.	Max.	Format	Unit
1069	Amplitude Profile Energy (Value should be entered 10 times higher)	AINT32	Get/Set	10	1	99990		0.1xJ
1070	Amplitude Profile Peak Power	AINT32	Get/Set	1	1	100		%
1071	Amplitude Start Ramp Time	AINT32	Get/Set	80	10	1000		ms
1073	Frequency Store at End	AINT32	Get/Set	1	0	1	Selection	
1074	Frequency Offset	AINT32	Get/Set	0	-500	500		Hz
1075	Hold time	AINT32	Get/Set	10	10	30000	0=OFF	ms
1076	Energy Breaking	AINT32	Get/Set	1	0	1	Selection	
1077	EB Target Amplitude	AINT32	Get/Set	3	1	100		%
1078	EB Time	AINT32	Get/Set	20	10	1000		ms
1079	After Burst	AINT32	Get/Set	1	0	1	Selection	
1080	AB Amplitude	AINT32	Get/Set	100	10	100		%
1081	AB Time	AINT32	Get/Set	100	100	2000		ms
1082	AB Delay	AINT32	Get/Set	100	100	2000		ms
1084	Scrub Amplitude	AINT32	Get/Set	100	10	100		%
1086	Time Error High (Cutoff)	AINT32	Get/Set	6000	10	30000	0=OFF	ms
1087	Energy Error High (Cutoff) (Value should be entered 10 times higher)	AINT32	Get/Set	1	1	99990	0=OFF	0.1xJ
1088	Peak Power Error High (Cutoff)	AINT32	Get/Set	10	1	100	0=OFF	%
1089	- Time Limit	AINT32	Get/Set	10	10	30000	0=OFF	ms
1090	+ Time Limit	AINT32	Get/Set	30000	10	30000	0=OFF	ms
1091	- Energy Limit (Value should be entered 10 times higher)	AINT32	Get/Set	1	1	99990	0=OFF	0.1xJ
1092	+ Energy Limit (Value should be entered 10 times higher)	AINT32	Get/Set	99990	1	99990	0=OFF	0.1xJ
1093	- Peak Power Limit	AINT32	Get/Set	1	1	100	0=OFF	%
1094	+ Peak Power Limit	AINT32	Get/Set	100	1	100	0=OFF	%
1095	Frequency Low (Cutoff Relative) (It depends on the power supply operating frequency. Frequency ranges will be added)	AINT32	Get/Set	20 kHz: 500	20 kHz: 1	20 kHz: 500	0=OFF	Hz
				30 kHz: 750	30 kHz: 1	30 kHz: 750		
				40 kHz: 1000	40 kHz: 1	40 kHz: 1000		
1096	Frequency High (Cutoff Relative) (It depends on the power supply operating frequency. Frequency ranges will be added)	AINT32	Get/Set	20 kHz: 500	20 kHz: 500	20 kHz: 200	0=OFF	Hz
				30 kHz: 750	30 kHz: 1	30 kHz: 750		
				40 kHz: 1000	40 kHz: 1	40 kHz: 1000		

B.1.1 Common Services

Table B.2 Common Services

Service Code	Service Name
14	Get_Attribute_Single
16	Set_Attribute_Single

B.2 Weld Data Class 101 (32 Instances)

The weld data for the preset number run.

Table B.3 Weld Data Class

Attribute ID	Description	Data Type	Access	Format	Unit
1210	Preset Name (Character 1)	AINT8	Get	-	-
1211	Preset Name (Character 2)	AINT8	Get	-	-
1212	Preset Name (Character 3)	AINT8	Get	-	-
1213	Preset Name (Character 4)	AINT8	Get	-	-
1214	Preset Name (Character 5)	AINT8	Get	-	-
1215	Preset Name (Character 6)	AINT8	Get	-	-
1216	Preset Name (Character 7)	AINT8	Get	-	-
1217	Preset Name (Character 8)	AINT8	Get	-	-
1218	Preset Name (Character 9)	AINT8	Get	-	-
1219	Preset Name (Character 10)	AINT8	Get	-	-
1220	Preset Name (Character 11)	AINT8	Get	-	-
1221	Preset Name (Character 12)	AINT8	Get	-	-
1222	Preset Name (Character 13)	AINT8	Get	-	-
1223	Preset Name (Character 14)	AINT8	Get	-	-
1224	Preset Name (Character 15)	AINT8	Get	-	-
1225	Preset Name (Character 16)	AINT8	Get	-	-
1226	Preset Name (Character 17)	AINT8	Get	-	-
1227	Preset Name (Character 18)	AINT8	Get	-	-
1228	Preset Name (Character 19)	AINT8	Get	-	-
1229	Preset Name (Character 20)	AINT8	Get	-	-
1240	Horn #	-	-	-	-
1241	Mode (0=Continuous, 1=Time, 2=Energy, 3=Peak Power, 4=Ground Detect)	-	-	-	-
1306*	Date (DD/MM/YY)	-	-	-	-
1307**	Time (SS:MM:HH)	-	-	-	-
1308***	Cycle Counter	-	-	-	-
1309-1357	Same as Class 67 attributes 1630-1678	-	-	-	-
1360	Weld Time	AINT32	Get		ms
1361	Hold Time	AINT32	Get		ms
1362	Energy	AINT32	Get		0.1 J
1363	Peak Power	AINT32	Get		%
1364	Average Power	AINT32	Get		%
1365	Average Amplitude 1	AINT32	Get		%
1366	Average Amplitude 2	AINT32	Get		%
1367	Recalled Res. Frequency	AINT32	Get		Hz

Table B.3 Weld Data Class

Attribute ID	Description	Data Type	Access	Format	Unit
1368	Start Frequency	AINT32	Get		Hz
1369	End Frequency	AINT32	Get		Hz
1370	Stored Frequency	AINT32	Get		Hz
1371	Res. Frequency OK	AINT32	Get	Selection	
1372	End Amplitude Set	AINT32	Get		%
1373	End Amplitude	AINT32	Get		%
1374	End PSV	AINT32	Get		%
1375	End Power	AINT32	Get		%
1376	End Current	AINT32	Get		%
1377	End Phase	AINT32	Get		deg. (°)
1378	End Temperature	AINT32	Get		°C

*(Date) It's given in the order: day, month, year - for example 180810

18 Hex = 24 decimal = day

08 Hex = 08 decimal = month

10 Hex = 16 decimal = year

Date = 24/08/16

** (Time) It's given in the order: seconds, minutes, hours - for example 371E0F

37 Hex = 55 decimal = seconds

1E Hex = 30 decimal = minutes

0F Hex = 15 decimal = hours

Time = 15:30:55

***ID 1308 is a 32 bit long command

B.2.1 Common Services

Table B.4 Common Services

Service Code	Service Name
14	Get_Attribute_Single

B.3 Stack Parameter Class 102 (16 Instances)

There is 1 instance for each horn preset. Attributes 1460-1474 are for seek, 1475-1489 are for test and 1490-1504 are for scan.

Table B.5 Stack Parameter Class (Seek Results)

Attribute ID	Description	Data Type	Access	Default	Min.	Max.	Format	Unit
1460	Time	AINT32	Get/Set	500	10	1000		ms
1462	Amplitude Start Ramp Time	AINT32	Get/Set	80	10	1000		ms
1465	Frequency Offset	AINT32	Get/Set	0	-500	500		Hz

Table B.6 Stack Parameter Class (Test Results)

Attribute ID	Description	Data Type	Access	Default	Min.	Max.	Format	Unit
1475	Amplitude Set A	AINT32	Get/Set	100	10	100	-	%

B.3.1 Common Services

Table B.7 Common Services

Service Code	Service Name
14	Get_Attribute_Single
16	Set_Attribute_Single

B.4 Common Stack Parameters (16 instances)

Table B.8 Common Stack Parameters

Attribute ID	Description	Data Type	Access	Default	Min.	Max.	Format	Unit
1505	Digital Tune Frequency	AINT32	Get/Set	20 kHz: 19,950	20 kHz: 19,450	20kHz: 20,450	-	Hz
				30 kHz: 30,000	30 kHz: 29,250	30 kHz: 30,750	-	Hz
				40 kHz: 39,900	40 kHz: 38,900	40 kHz: 40,900	-	Hz

B.5 Stack Status Class 103 (16 Instances)

The horn status for the horn preset number run. 1625-1694 are for seek, 1725-1794 are for test and 1825-1894 are for scan.

Table B.9 Stack Status Class (Seek)

Attribute ID	Name	Data Type	Access	Format	Unit
1625*	RTC, Date (DD/MM/YY)	-	-	-	-
1626**	RTC, Time (SS:MM:HH)	-	-	-	-
1630	OL - Overload Group 0 (bit 0-31)	-	-	-	-
1634	CU - Cutoffs Group 1 (bit 0-31)	-	-	-	-
1638	SE - Setup Group 2 (bit 0-31)	-	-	-	-
1642	CM - Cycle Modified Group 3 (bit 0-31)	-	-	-	-
1646	WA - Warnings Group 4 (bit 0-31)	-	-	-	-
1650	LM - Limits Group 5 (bit 0-31)	-	-	-	-
1654	EQ - Equipment Failure Group 6 (bit 0-31)	-	-	-	-
1658	NC - No Cycle Group 7 (bit 0-31)	-	-	-	-
1662	CF - Comm. Failure Group 8 (bit 0-31)	-	-	-	-
1666	TP - Temperature Group 9 (bit 0-31)	-	-	-	-
1670	HW - Hardware Group A (bit 0-31)	-	-	-	-
1674	NO - No Cycle Overload Group B (bit 0-31)	-	-	-	-
1678	Error Reason	-	-	-	-
1680	Time	AINT32	Get	-	ms
1681	Average Amplitude	AINT32	Get	-	%
1682	Recalled Digital Tune	AINT32	Get	-	Hz
1683	Start Frequency	AINT32	Get	-	Hz
1684	End Frequency	AINT32	Get	-	Hz
1685	Stored Frequency	AINT32	Get	-	Hz
1686	Res. Frequency OK	AINT32	Get	Selection	
1687	End Amplitude Set	AINT32	Get	-	%
1688	End Amplitude	AINT32	Get	-	%
1689	End PSV	AINT32	Get	-	%
1690	End Power	AINT32	Get	-	%
1691	End Current	AINT32	Get	-	%
1692	End Phase	AINT32	Get	-	deg. (°)
1693	End Temperature	AINT32	Get	-	°C
1694	Reserved	AINT32	Get	-	-

*(Date) It's given in the order: day, month, year - for example 180810

18 Hex = 24 decimal = day

08 Hex = 08 decimal = month

10 Hex = 16 decimal = year

Date = 24/08/16

** (Time) It's given in the order: seconds, minutes, hours - for example 371E0F

37 Hex = 55 decimal = seconds

1E Hex = 30 decimal = minutes
 0F Hex = 15 decimal = hours
 Time = 15:30:55

Table B.10 Stack Status Class (Test)

Attribute ID	Name	Data Type	Access	Format	Unit
1725-1778	Same as 1625-1678 for test	-	-	-	-
1780	Time	AINT32	Get	-	ms
1781	Average Amplitude A	AINT32	Get	-	%
1782	Average Amplitude B	AINT32	Get	-	%
1783	Recalled Res. Frequency	AINT32	Get	-	Hz
1784	Res. Frequency OK	AINT32	Get	Selection	-
1785	Start Frequency	AINT32	Get	-	Hz
1786	End Frequency	AINT32	Get	-	Hz
1787	End Amplitude Set	AINT32	Get	-	%
1788	End Amplitude	AINT32	Get	-	%
1789	End PSV	AINT32	Get	-	%
1790	End Power	AINT32	Get	-	%
1791	End Current	AINT32	Get	-	%
1792	End Phase	AINT32	Get	-	deg. (°)
1793	End Temperature	AINT32	Get	-	°C
1794	Reserved	AINT32	Get	-	-

Table B.11 Stack Status Class (Scan)

Attribute ID	Name	Data Type	Access	Format	Unit
1825-1878	Same as 1625-1678 except for scan	-	-	-	-
1880	Time	AINT32	Get	-	ms
1881	Start Frequency	AINT32	Get	-	Hz
1882	End Frequency	AINT32	Get	-	Hz
1883	End Amplitude	AINT32	Get	-	%
1884	End PSV	AINT32	Get	-	%
1885	End Power	AINT32	Get	-	%
1886	End Current	AINT32	Get	-	%
1887	End Phase	AINT32	Get	-	deg. (°)
1888	End Temperature	AINT32	Get	-	°C

B.5.1 Common Services

Table B.12 Common Services

Service Code	Service Name
14	Get_Attribute_Single

B.6 Alarm Data Class 104 (1 Instances)

Table B.13 Alarm Data Class

Attribute ID	Name	Data Type	Access	Format
200	OL - Overload Group 0 (bit 0-31)	UINT32	Get	OEPB
204	CU - Cutoffs Group 1 (bit 0-31)	UINT32	Get	OEPB
208	SE - Setup Group 2 (bit 0-31)	UINT32	Get	OEPB
212	CM - Cycle Modified Group 3 (bit 0-31)	UINT32	Get	OEPB
216	WA - Warnings Group 4 (bit 0-31)	UINT32	Get	OEPB
220	LM - Limits Group 5 (bit 0-31)	UINT32	Get	OEPB
224	EQ - Equipment Failure Group 6 (bit 0-31)	UINT32	Get	OEPB
228	NC - No Cycle Group 7 (bit 0-31)	UINT32	Get	OEPB
232	CF - Comm. Failure Group 8 (bit 0-31)	UINT32	Get	OEPB
236	TP - Temperature Group 9 (bit 0-31)	UINT32	Get	OEPB
240	HW - Hardware Group A (bit 0-31)	UINT32	Get	OEPB
244	NO - No Cycle Overload Group B (bit 0-31)	UINT32	Get	OEPB

B.6.1 Common Services

Table B.14 Common Services

Service Code	Service Name
14	Get_Attribute_Single

B.7 System Information Class 105 (1 Instances)

Table B.15 System Information Class

Attribute ID	Name	Format
150	PS Frequency	Hz
151	PS Wattage	Watts
154	PS Serial Number	-

B.7.1 Common Services

Table B.16 Common Services

Service Code	Service Name
14	Get_Attribute_Single

B.8 Other Information Class 112 (1 Instances)

Table B.17 Other Information Class

Attribute ID	Name	Data Type	Access
50	Get Access Token	UINT8	Get
51	Put Access Token	UINT8	Get/Set
100	DCP, HW Version	UINT32	Get
101	DCP, FPGA-Version	UINT32	Get
102	DCP, Bootloader-Version	UINT32	Get
103	DCP, Firmware-Version	UINT32	Get
110	WC, HW Version	UINT32	Get
112	WC, Bootloader-Version	UINT32	Get
113	WC, Firmware-Version	UINT32	Get
170*	RTC, Date (DD/MM/YY)	UINT32	Get/Set
171**	RTC, Time (SS:MM:HH)	UINT32	Get/Set

*(Date) It's given in the order: day, month, year - for example 180810

18 Hex = 24 decimal = day

08 Hex = 08 decimal = month

10 Hex = 16 decimal = year

Date = 24/08/16

** (Time) It's given in the order: seconds, minutes, hours - for example 371E0F

37 Hex = 55 decimal = seconds

1E Hex = 30 decimal = minutes

0F Hex = 15 decimal = hours

Time = 15:30:55

Table B.18 System Configuration Parameters

Attribute ID	Name	Data Type	Access
950	Clear Memory Before Seek	UINT32	Get/Set
951	Clear Memory with Reset	UINT32	Get/Set
952	Set digital Tine with Horn Scan	UINT32	Get/Set
953	Clear Memory at Power Up	UINT32	Get/Set

B.8.1 Common Services

Table B.19 Common Services

Service Code	Service Name
14	Get_Attribute_Single
16	Set_Attribute_Single

B.9 Identity Class 1 (1 Instance)

The Identity Class provides identification and general information about the device. The first instance identifies the whole device. It is used for electronic keying and by applications wishing to determine what devices are on the network. The following tables contain the attribute, status, common services, and vendor specific services information for the Identity Class.

Table B.20 Identity Class

Attribute ID	Name	Data Type	Data Value	Access
1	Vendor ID	UINT	1283	Get
2	Product Type	UINT	43	Get
3	Product Code	UINT	2	Get
4	Revision	UINT	1	Get
6	Serial #	AINT		Get
7	Product Name	SHORT STRING32	DCX-FE	Get

B.9.1 Common Services

Table B.21 Common Services

Service Code	Service Name
14	Get_Attribute_Single

Appendix C: Timing Diagrams

C.1 Timing Diagrams 234

C.1 Timing Diagrams

C.1.1 Weld Cycle

Figure C.1 Weld Cycle

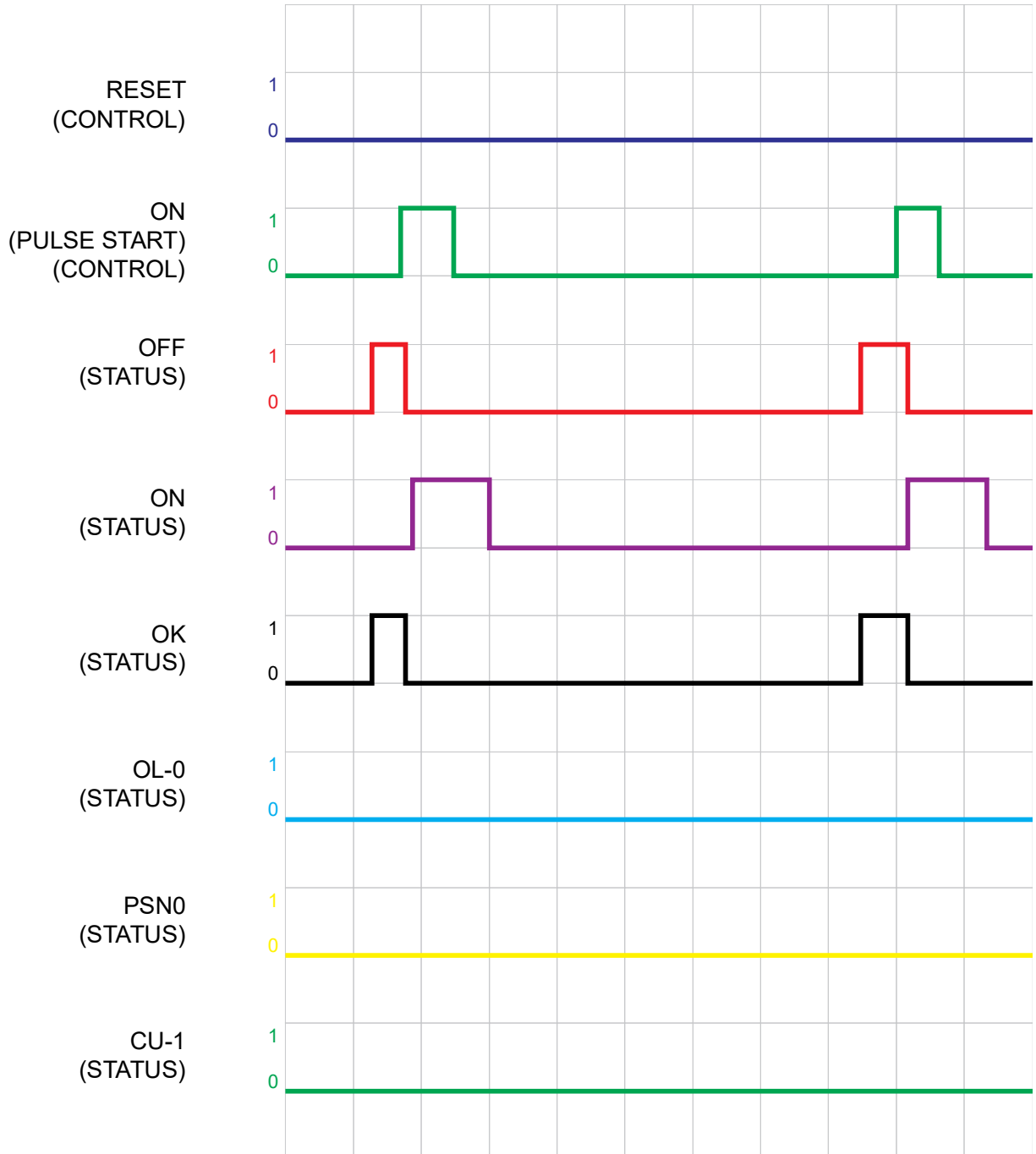

C.1.2 Weld Cycle With Overload Alarm and External Reset

Figure C.2 Weld Cycle With Overload Alarm and External Reset

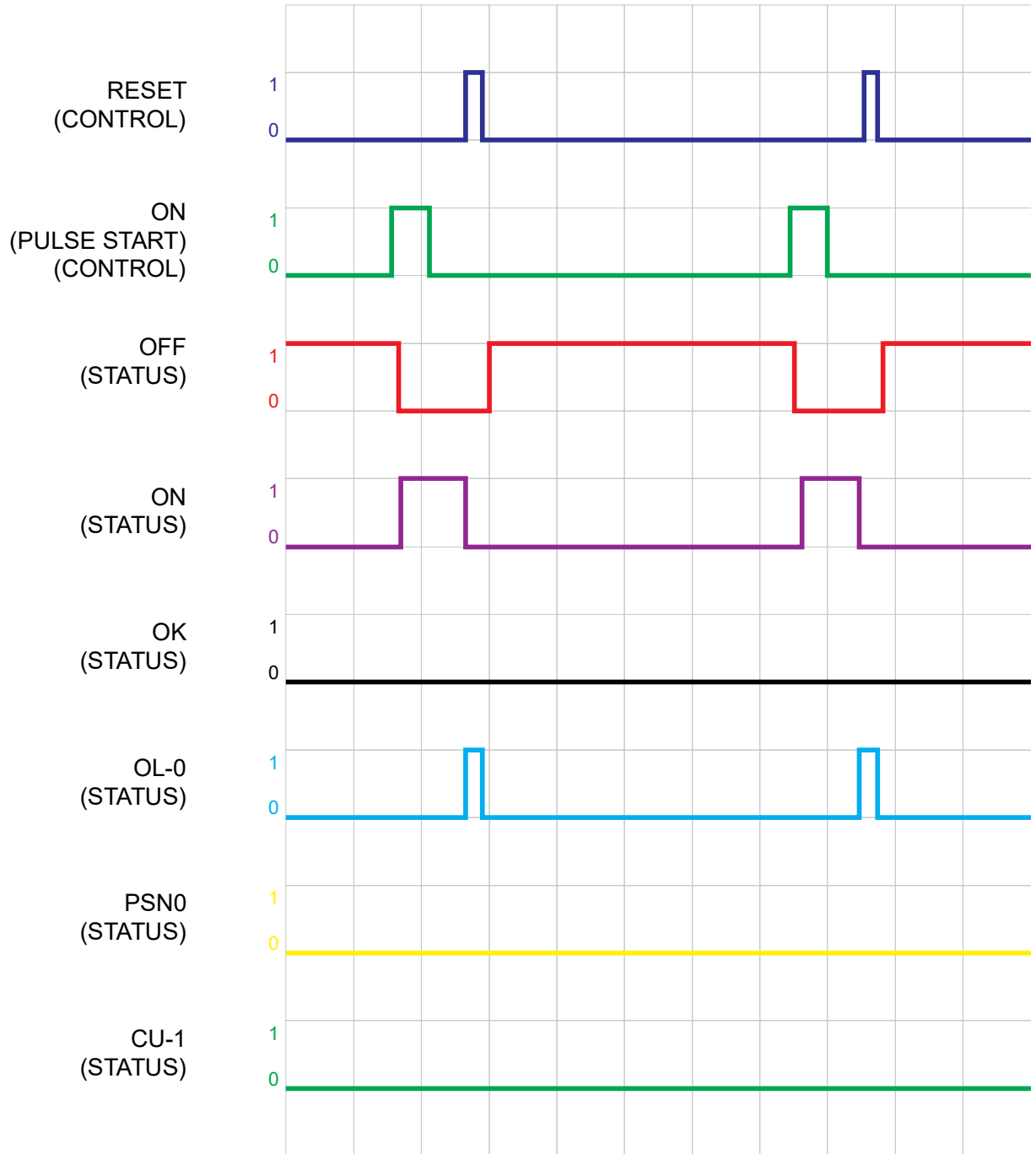

C.1.3 Weld Cycle With Cutoff Alarms and External Reset

Figure C.3 Weld Cycle With Cutoff Alarms and External Reset

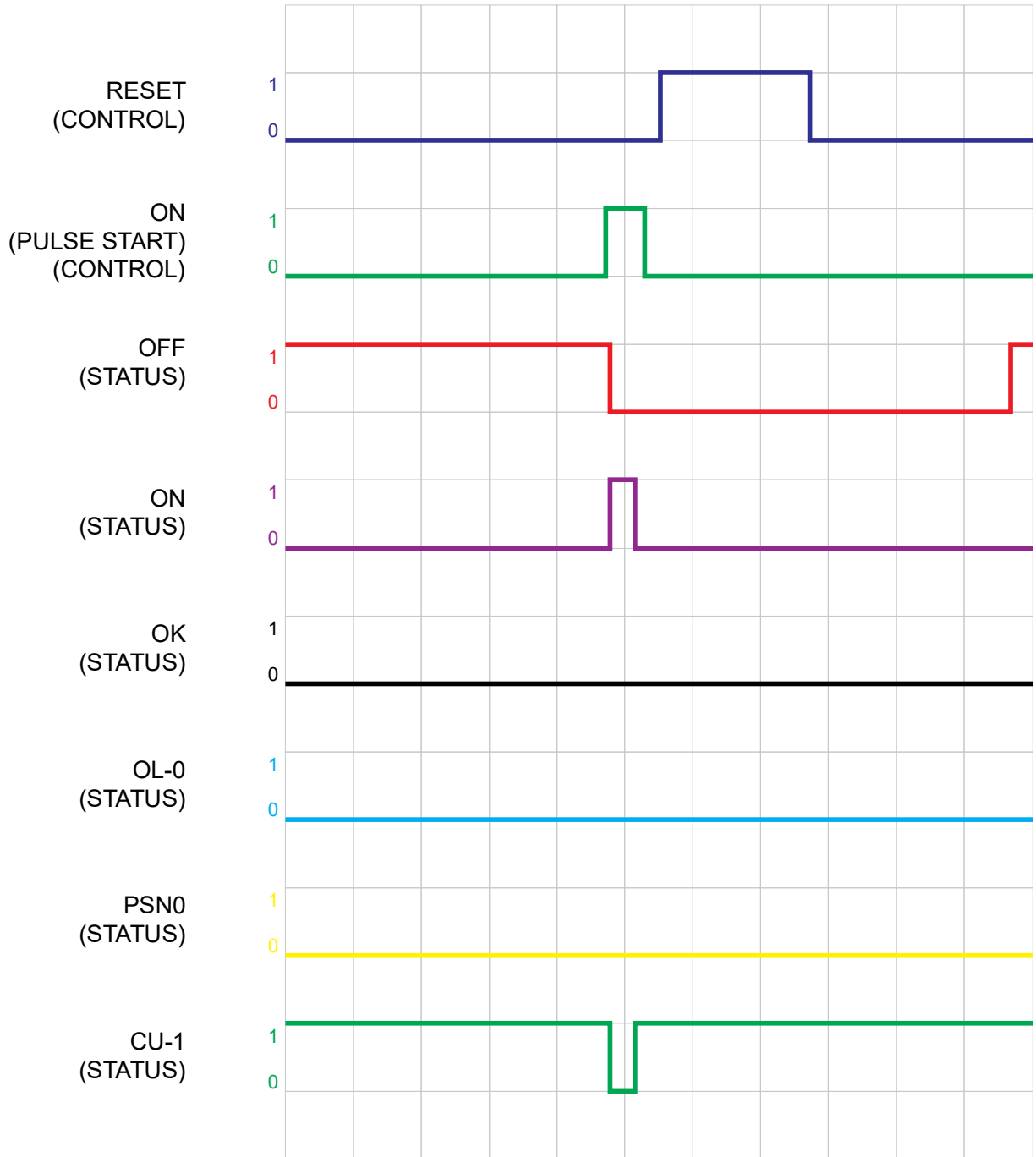

C.1.4 Weld Cycle Using Presets

Figure C.4 Weld Cycle Using Presets

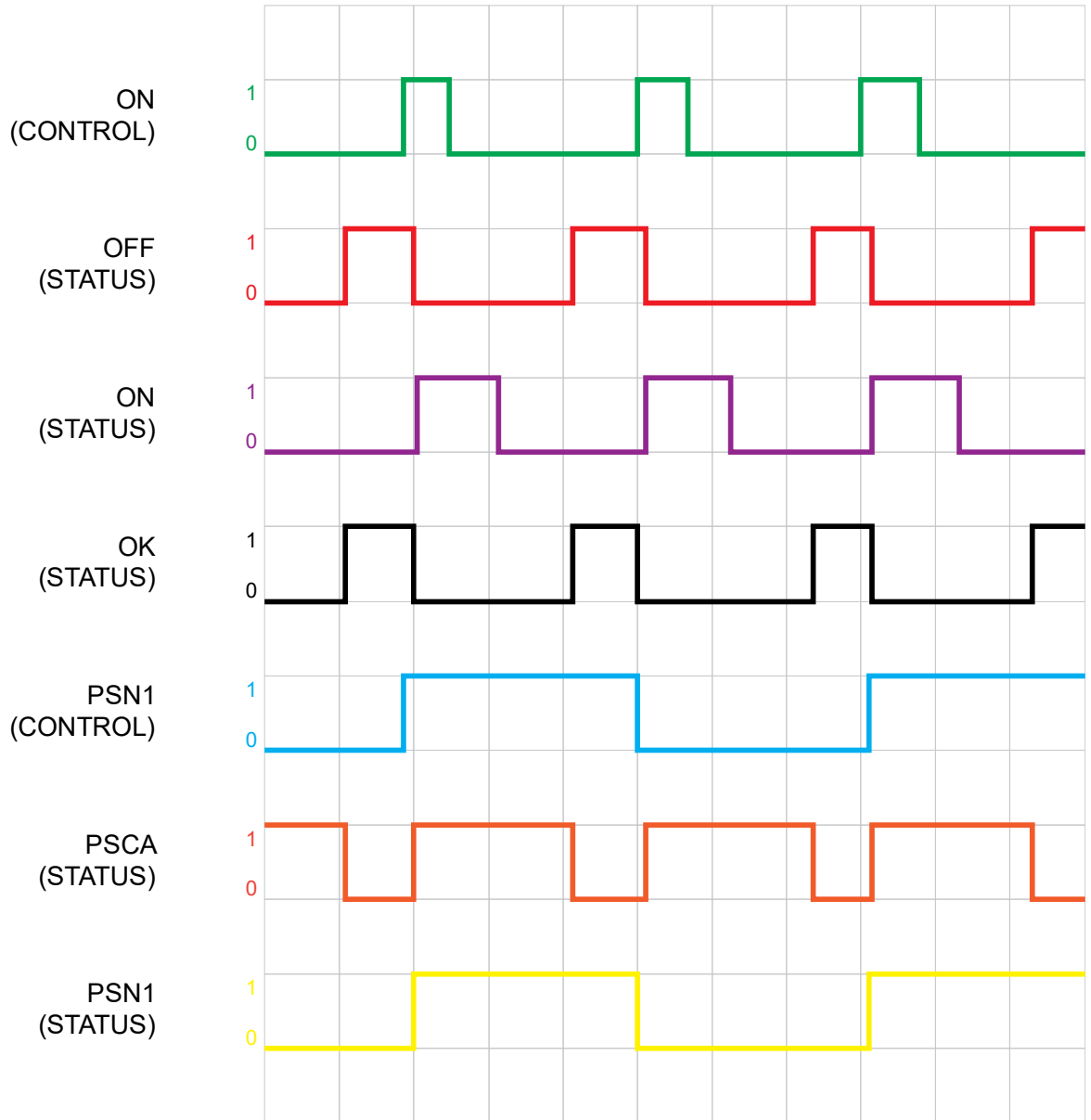

C.1.5 RF Switching Direct With Feedback With And Without Alarm

Figure C.5 RF Switching Direct With Feedback With And Without Alarm

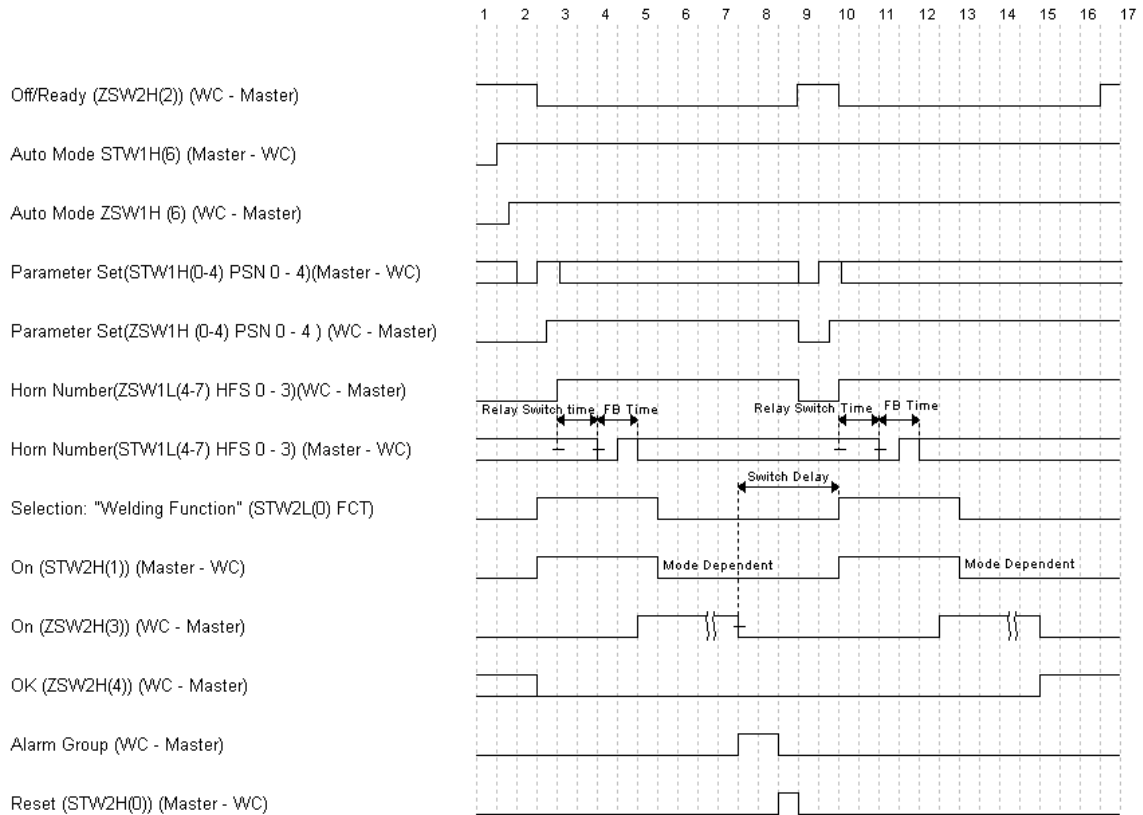

C.1.6 RF Switching I/O Direct With Feedback With And Without Alarm

Figure C.6 RF Switching I/O Direct With Feedback With And Without Alarm

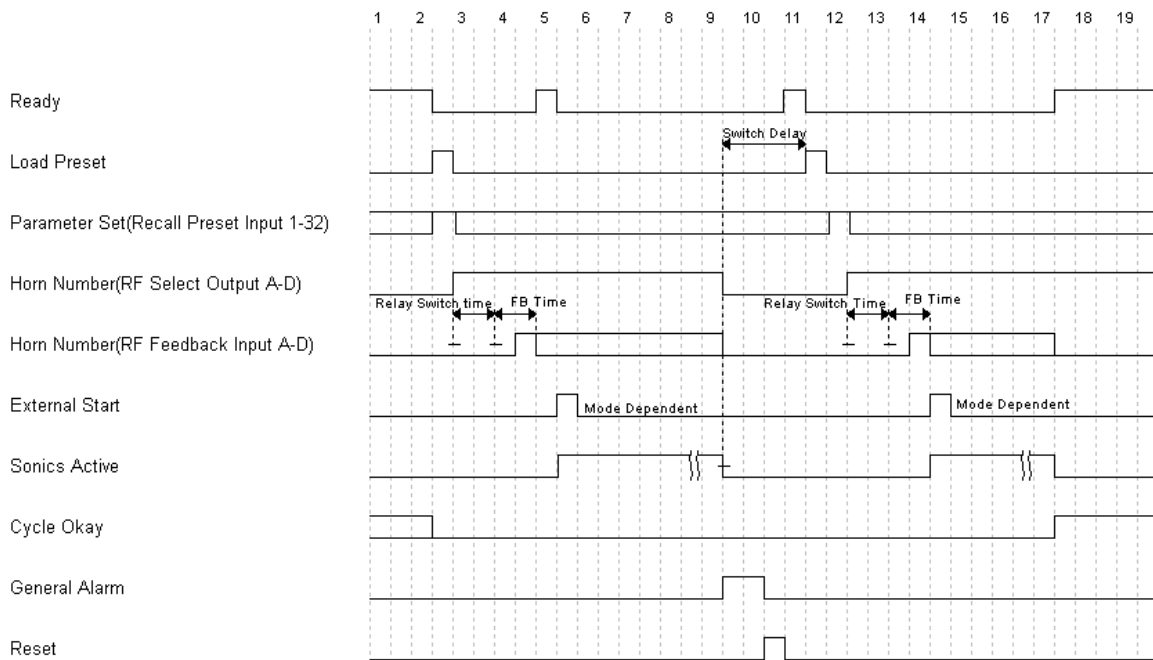

C.1.7 RF Switching I/O Direct With Feedback With And Without Alarm And Load On Start

Figure C.7 RF Switching I/O Direct With Feedback With And Without Alarm And Load On Start

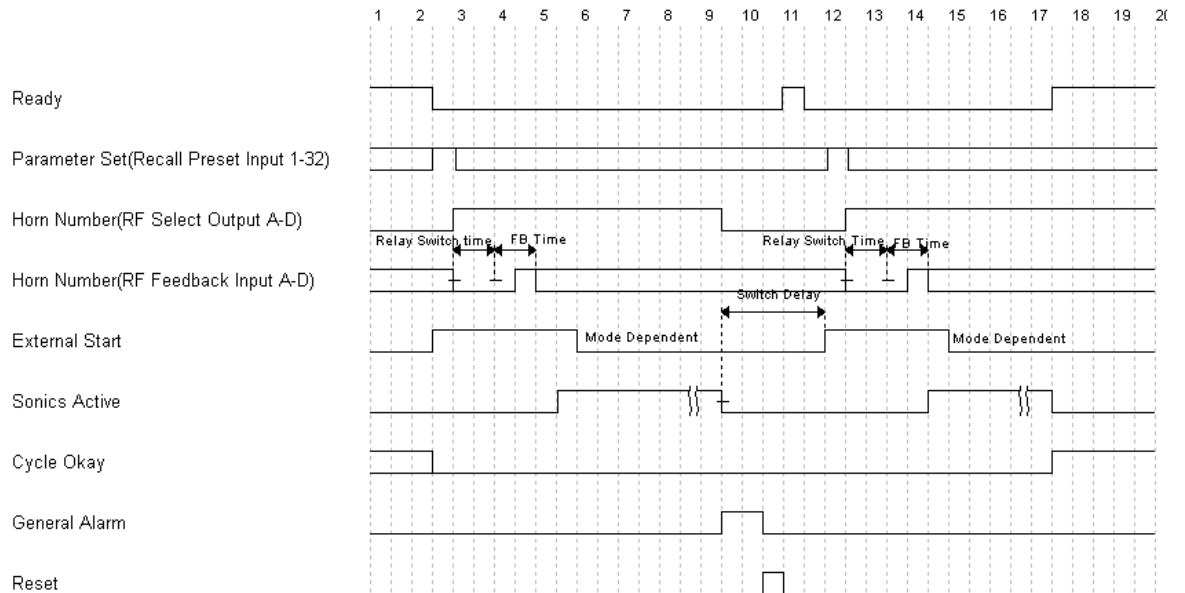

C.1.8 RF Switching I/O With Off With And Without Alarm And Load On Start

Figure C.8 RF Switching I/O With Off With And Without Alarm And Load On Start

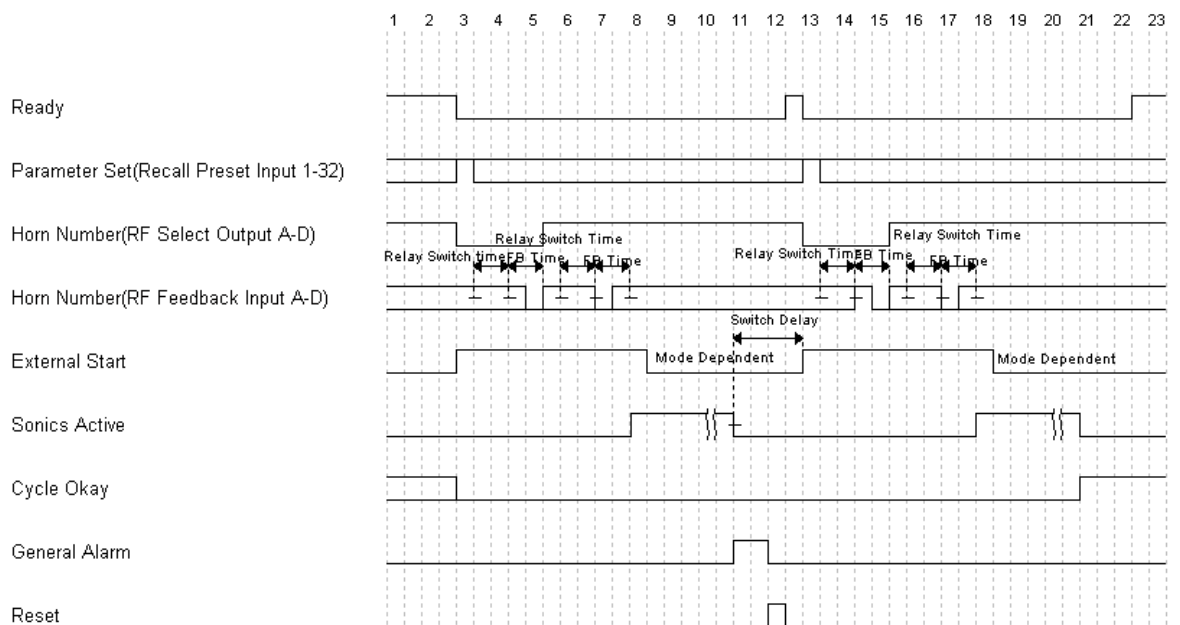

C.1.9 RF Switching I/O With Off With Feedback With And Without Alarm

Figure C.9 RF Switching I/O With Off With Feedback With And Without Alarm

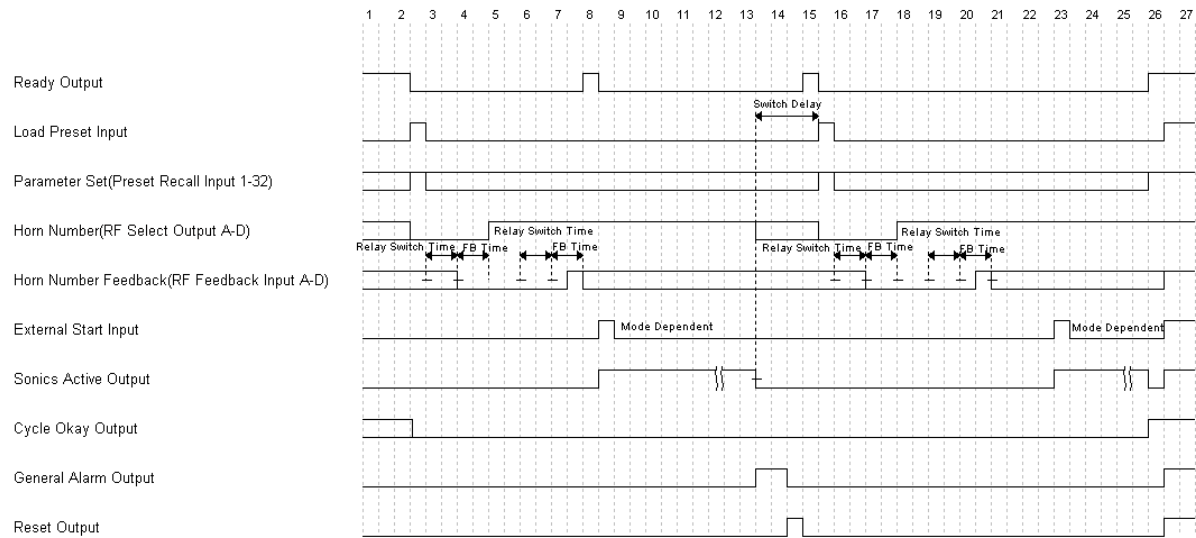

C.1.10 RF Switching With Off With Feedback With And Without Alarm

Figure C.10 RF Switching With Off With Feedback With And Without Alarm

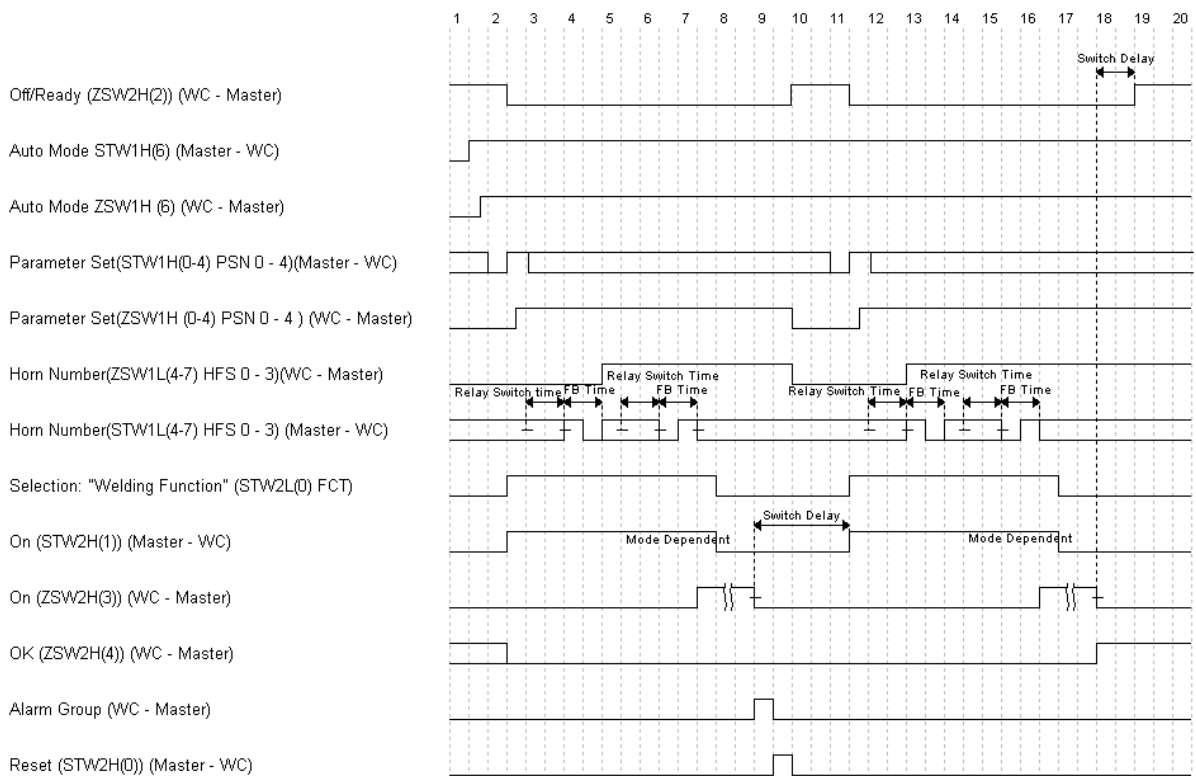

C.1.11 Timing Diagram For All Other Modes With Actuator

Figure C.11 Timing Diagram For All Other Modes With Actuator

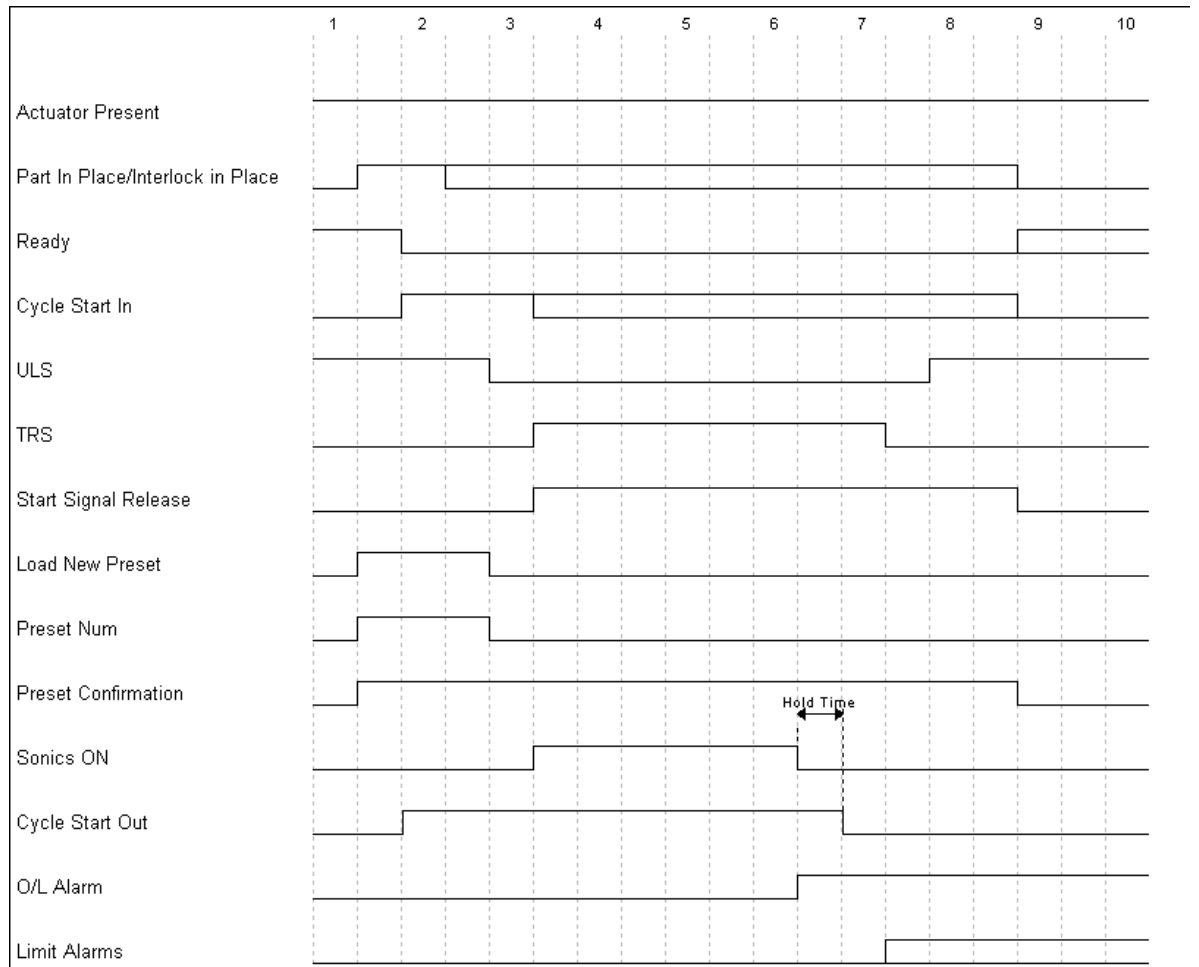

C.1.12 Timing Diagram For Cycle Abort With Actuator

Figure C.12 Timing Diagram For Cycle Abort With Actuator

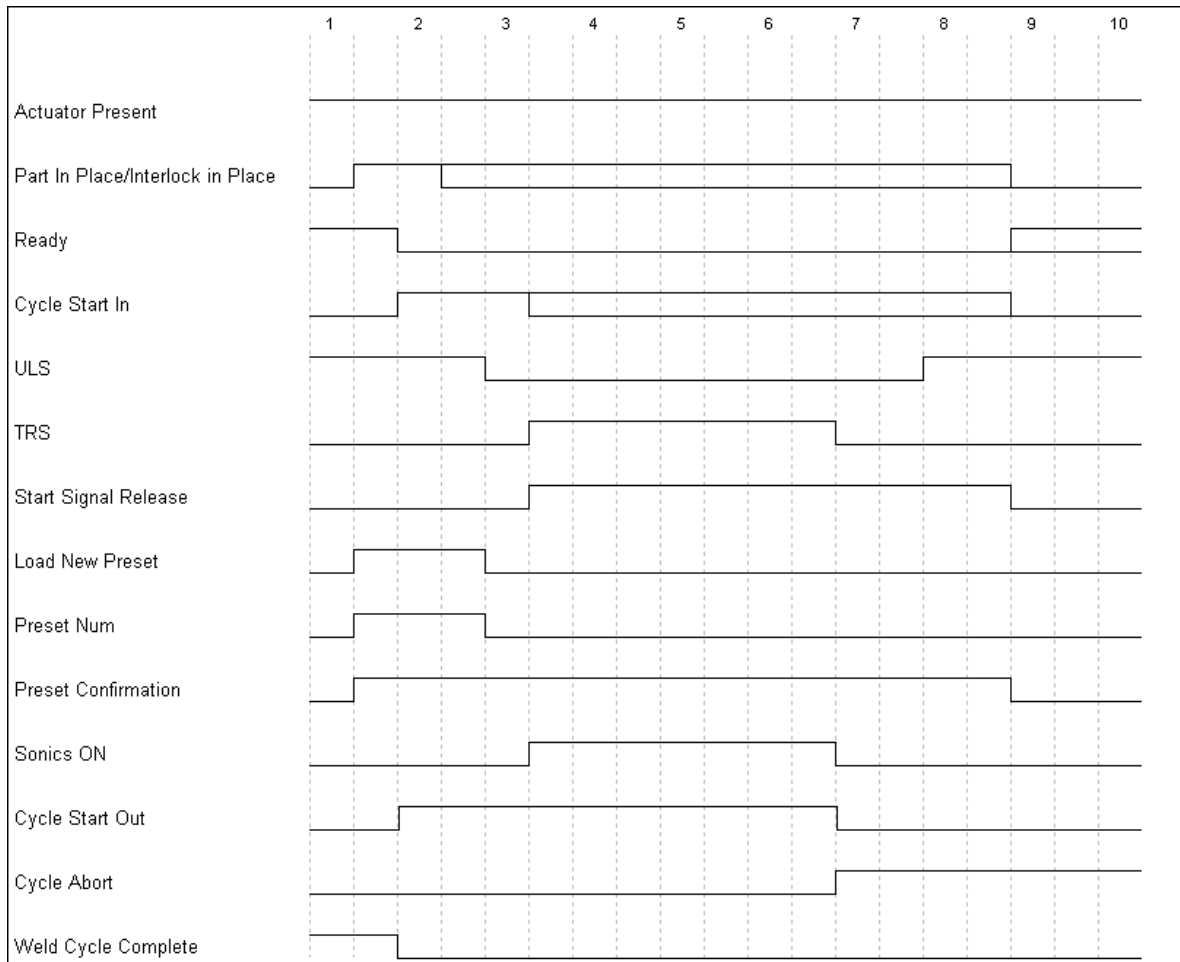

C.1.13 Timing Diagram For Ground Detect With Actuator

Figure C.13 Timing Diagram For Ground Detect With Actuator

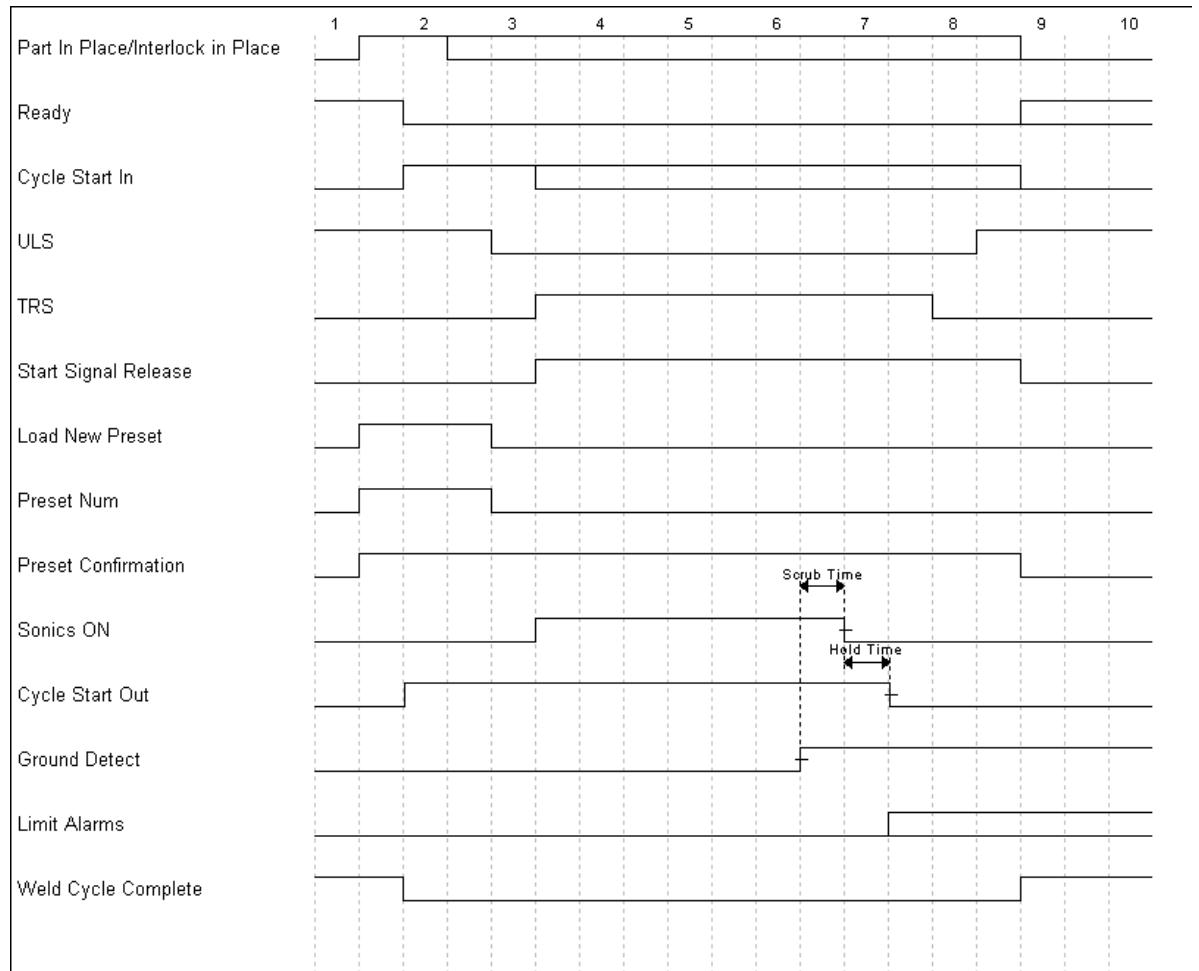

Appendix D: Signal Diagrams

D.1 Signal Diagrams 246

D.1 Signal Diagrams

Figure D.1 Continuous Mode

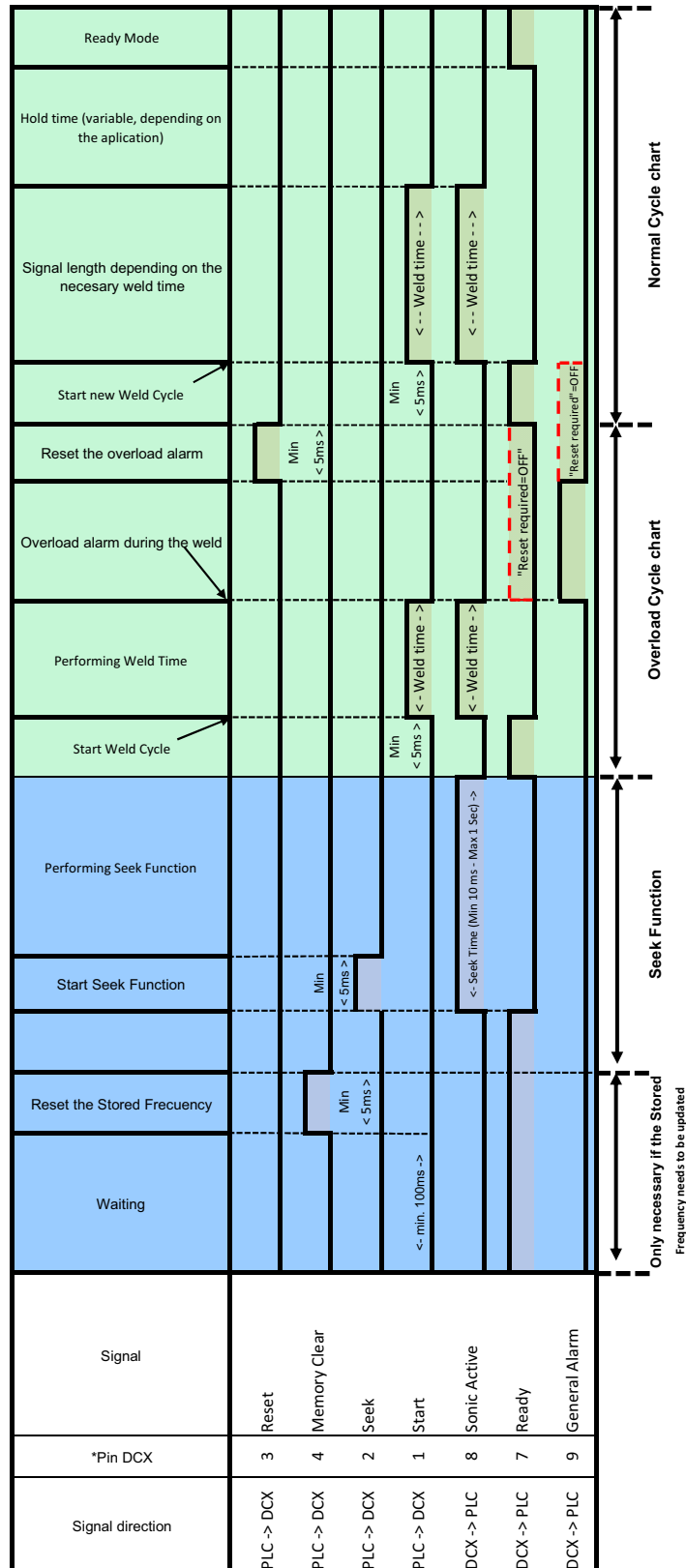

*Inputs/Outputs are configurable on the User I/O Configuration webpage.

--- If Reset Required is unchecked for Overload in Alarm Webpage interface, Ready signal will be enabled after Start switch is released.

Figure D.2 Time Mode

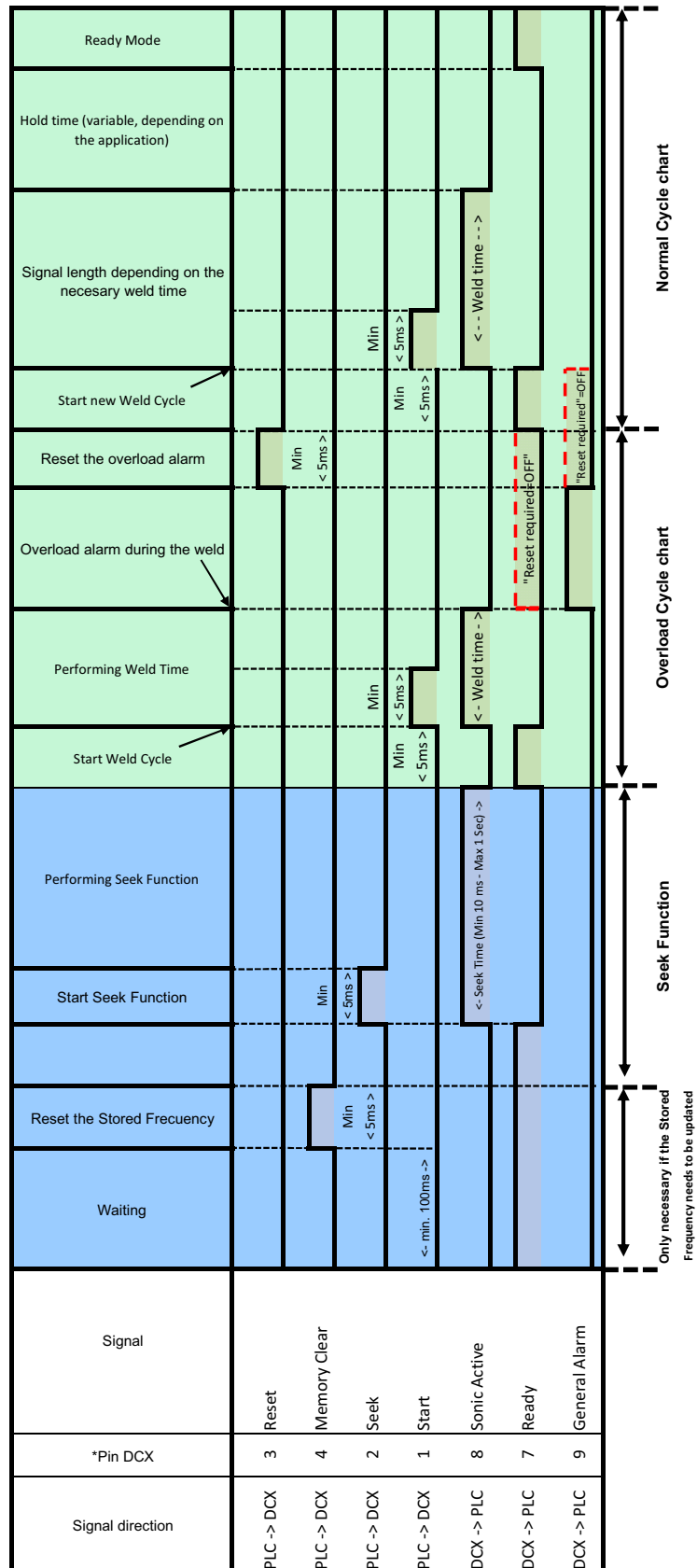

*Inputs/Outputs are configurable on the User I/O Configuration webpage.

--- If Reset Required is unchecked for Overload in Alarm Webpage interface, Ready signal will be enabled when General Alarm becomes active.

Figure D.3 AE Actuator

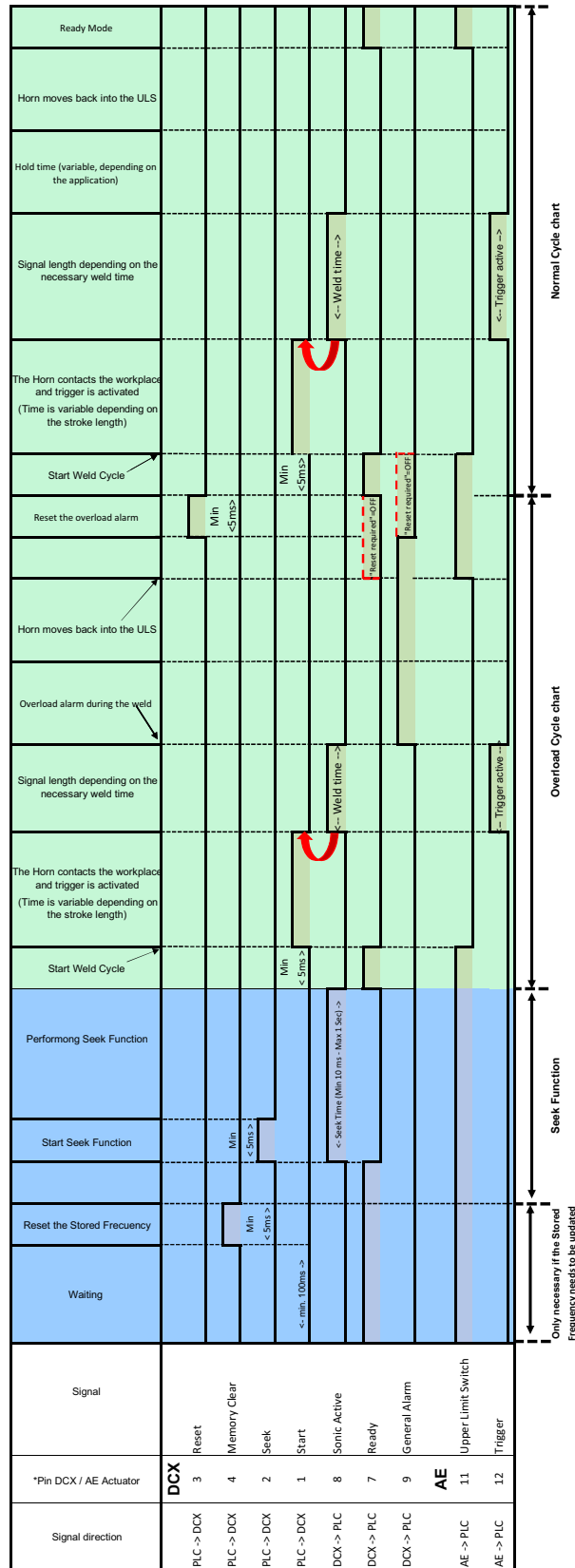

*Inputs/Outputs are configurable on the User I/O Configuration webpage.

↻ Start signal should be released by Sonic Active

--- If Reset Required is unchecked for Overload in Alarm Webpage interface, Ready signal will be enabled when Upper Limit Switch becomes active.

Appendix E: Manual's Revisions

E.1 Manual's Revisions 250

E.1 Manual's Revisions

Refer to the table below for the appropriate manual revision depending on your Power Supply's manufacturing date.

Table E.1 Manual's Revisions

Manual's Revisions	Power Supply's Manufacturing Date	
	From	To
00	May 2022	September 2024
01	October 2024	March 2026
02	April 2026	To date

Figure E.1 Manufacturing date on the Information label

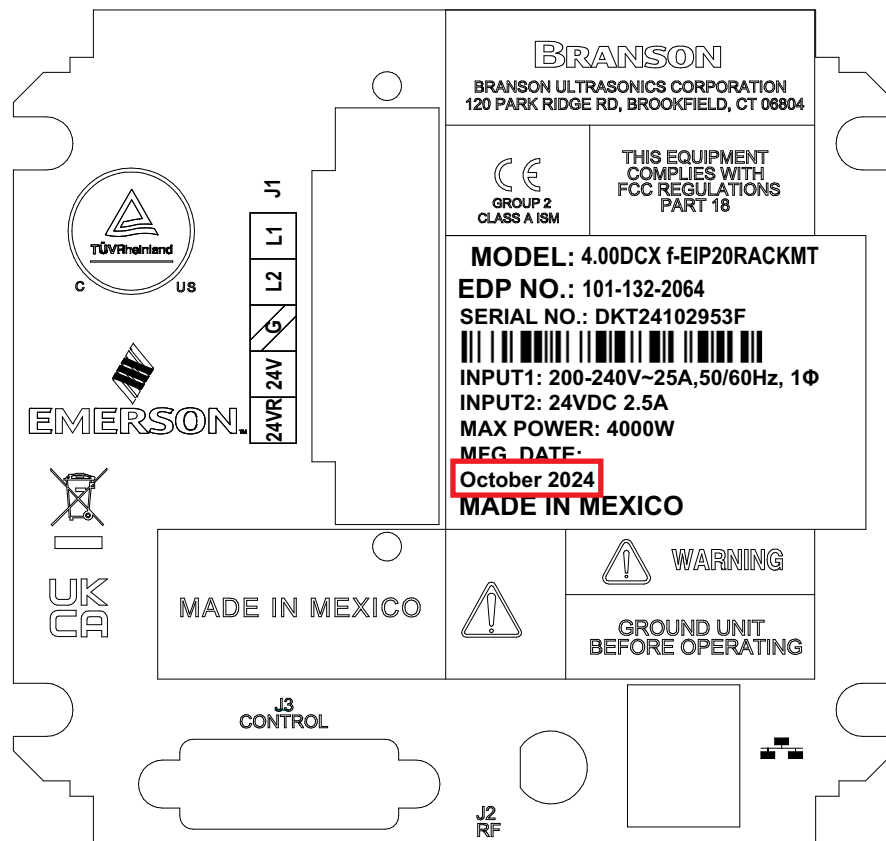
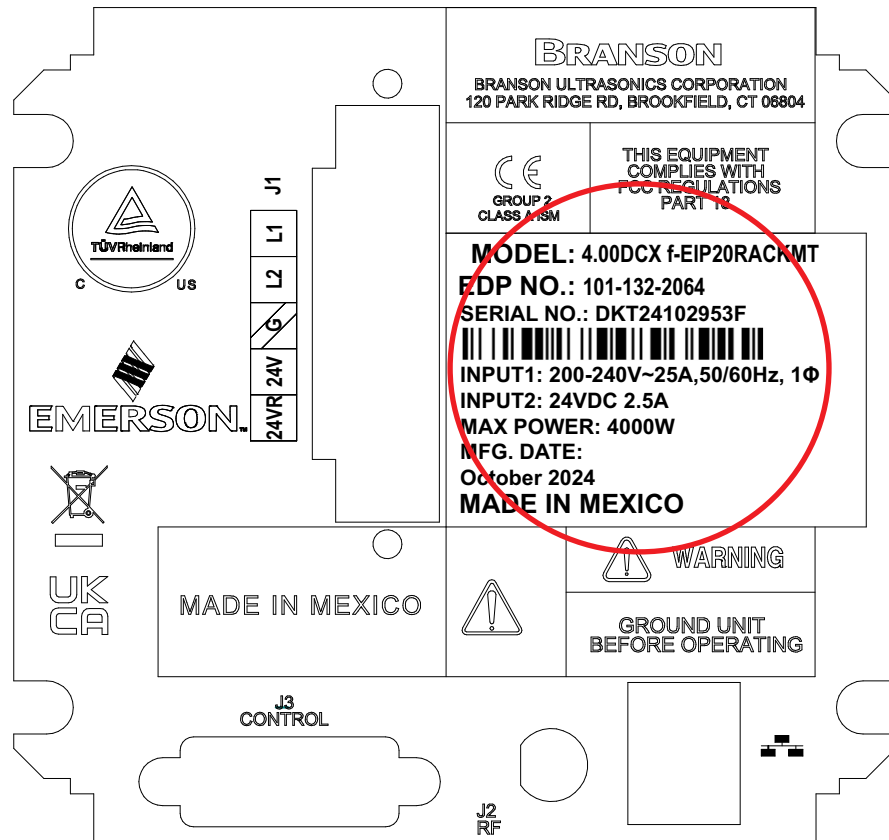
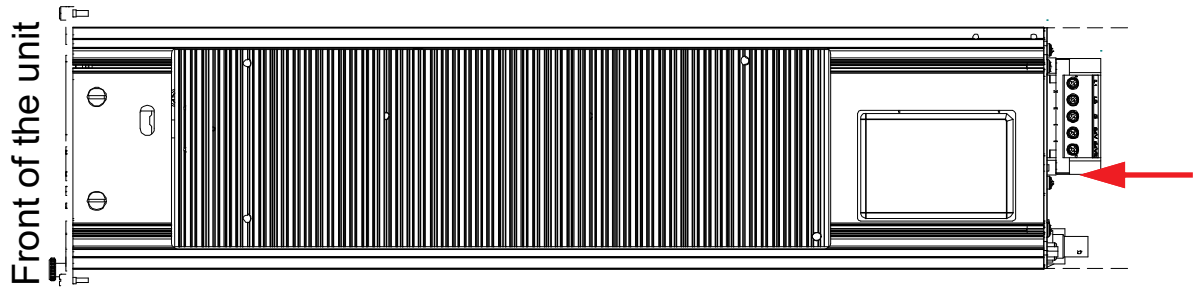

Figure E.2 Location of the Information label on the back of the DCX F-EIP Power Supply





Index

Numerics

24 V Indicator 21

A

Acoustic Stack 75
Actuator 19, 27
Afterburst 74
Alarm 27
Alarm Data 229
Alarm Icon 24
Alarm Reset Key 20
Alarms 124, 203
Amplitude 27, 122
Amplitude Control 27
Analog Input Functions 68
Analog Output Functions 69
autotune with memory (AT/M) 15
Autotuning 17, 19

B

Booster 19, 27, 94
Boosters 195
Branson
 how to contact 8

C

Cables 35
Circle Icon 24
Clamping Force 27
Cold Start 27, 202
Communication Failure Alarms 214
Compatibility 16
Configuration Key 21
Connections 25
Continuous 98
Continuous Mode 99
Continuous Mode Icon 22
Control Word (STW1) 150
Control Word (STW2) 153
Controls and Indicators 20
Converter 19, 27, 94
Converter Cooling 80
Converters 194
Converters and Boosters 85
Counters 27
Cutoff Alarms 206
Cutoffs 74
Cycle Modified Alarms 208

D

- DCX Inputs/PLC Outputs 154
- DCX Outputs/PLC Inputs 155
- Declaration of Conformity 42
- Degating 27
- Delivery 33
- Delivery and Handling 31
- Digital Amplitude Setting 17
- Digital Input Functions 64
- Digital Output Functions 66
- Drop Test 32

E

- Electrical Connections 57
- Electrical Problems 199
- Electrical Specifications 38
- Emissions 7
- End of Weld Store 74
- Energy 98
- Energy Brake 74
- Energy Director 27
- Energy Mode 103
- Energy Mode Icon 22
- Environmental Requirements 53
- Environmental Specifications 32, 38
- Equipment Failure Alarms 211
- Ethernet Port 21, 25, 57
- EtherNet/IP 17, 140
- EtherNet/IP Commands 219
- EtherNet/IP Connectors 21
- EtherNet/IP Operation 139
- EtherNet/IP Overview 143
- EtherNet/IP Specifications 142
- EtherNet/IP Status Indicator 21
- Explicit Message 144
- External Amplitude Control 27, 123
- External Frequency Control 27

F

- Features 17
- Fieldbus 27
- Fixture 27
- Flash 27
- Forming 27
- Frequency 27
- Frequency Offset 17, 28, 74
- Fretting Corrosion 28
- Front Panel 20

G

- Gain 28
- General Maintenance 184
- General Precautions 6
- Glossary 27
- Ground Detect 98
- Ground Detect Icon 23

Ground Detect Mode 107

H

Hardware Alarms 215
Horn 19, 28, 94
Horn Amplitude 28
Horn Signature 17, 28
Humidity 32

I

I/O Connections 138
Identity Object 232
Implicit (I/O) Message 144
Implicit Message for Reset 161
Implicit Message for Run 159
Implicit Message for Scan 160
Implicit Message for Seek 160
Implicit Messaging 149
Input Power Connection 72
Insertion 28
Installation and Setup 47
Installation Requirements 49
Installation Steps 55
Intended Use of the System 6
Interface 28
Introduction 13
Inventory 35

J

Joint 28
Joule Icon 23

L

LCD 17, 20
LCD Bar-Graph 133
LED Status Indicator 140
Limit Alarms 210
Limits 74
Line Input Connector 25, 57
Line Regulation 17
line regulation 15
Load Regulation 17
load regulation 15
Location 49

M

Maintenance 183
Membrane Keys 17
Mode 74
Mount the Power Supply 56
Mounting Considerations 56

N

No Cycle Alarms 213
Non-Cycle Overload Alarms 216

Number Sign Icon 23
Numeric Display 22

O

Operation 97
Other Information 231
Other Items 197
Output Power 71
Overload Alarms 204

P

Parameter 28
Parameter Range 28
Parameter Set Object 220
Passcodes 18
Peak Power 98
Peak Power Icon 23
Peak Power Mode 105
Percentage Icon 23
Physical Description 41
Pneumatic Requirements 54
Power Supply 28
Power Up 74
Power/Frequency Bar-Graph 24
Power-On Indicator 21
Preventive Maintenance 186
Primary Parameters 98

R

Ramp Starting 17
Receiving 33
Recondition the Stack 187
Registers 125, 127
Regulatory Compliance 7
Returning Equipment 36
RF Connector 25, 57

S

Safety and Support 1
Safety Requirements 2
Seek 18, 28
seek
 timed 15
Seek Ramp 74
Setup 74
Setup Alarms 207
Shipping and Handling 32
Shock / Vibration (transit) 32
Solid Mount Boosters 95
Sonics Active Indicator 23
Spare Stock 192
Stack Function 154
Stack Parameter Object 225
Stack Status Object 227
Stack Torque Values 189

- Staking 28
- Start Ramp 74
- Start-up Diagnostics 18
- Status Word (ZSW1) 156
- Status Word (ZSW2) 159
- Storage / Shipping Temperature 32
- STW1 150
- STW2 153
- Suggested Spares 193
- Swaging 28
- Symbols 2
- System Cables 192
- System Information 230
- System Protection 18

T

- Technical Specifications 37
- Test Procedure 136
- Thermoplastic 28
- Thermoset 28
- Time 98
- Time Icon 23
- Time Mode 101
- Time Mode Icon 22
- Timed Seek 18, 74
- timed seek 15
- Timing Diagrams 233
- Token 28
- Troubleshooting 199
- True Wattmeter 18

U

- Ultrasonic Power 28
- Ultrasonic Power Problems 200
- Ultrasonic Stack 94
- Ultrasonic Welding 29
- Ultrasonics Test Key 21
- Unpacking 34
- Up/Down Keys 20
- User I/O Cable Pin Assignments 60
- User I/O Connections 58
- User I/O Connector 25, 57
- User ID 18, 29

W

- Warning Alarms 209
- Warnings 2
- Web Page Interface 18
- web page interface 15
- Weld Amplitude 74
- Weld Cycle Problems 201
- Weld Data Object 223
- Weld System 29
- Welding System 17
- Window Limit High 118
- Window Limit Low 120

Window Limits 117
Wiring Considerations 49

Z

ZSW1 156
ZSW2 159