



Automation Acoustic Clamp

General Description:

The Branson Acoustic Clamp is designed for use in automation where clamping of an ultrasonic stack (converter and booster) is required. The acoustic clamp keeps the stack aligned to the product being welded without causing stress at the clamping areas around the stack. The Clamp can be mounted at any angle or orientation.

The Acoustic Clamp is available in three sizes to accommodate the frequency of the stack and minimize the mounting area. The Acoustic Clamp's body and door are constructed from cast aluminum and include pre-drilled and tapped holes for mounting.

Key Features:

- Available in 40, 30 and 20 kHz sizes
- Designed for maximum support and rigidity
- Open top design allows for access to both the RF and air cooling connections
- Compatible with all CR and CH type converters and standard boosters
- Precision locating hole and mounting pattern on the back allows for rapid clamp assembly change with precise alignments
- Bolt mount option allows the removal of only the cover for stack replacement or removal of the entire clamp assembly for quick tooling change

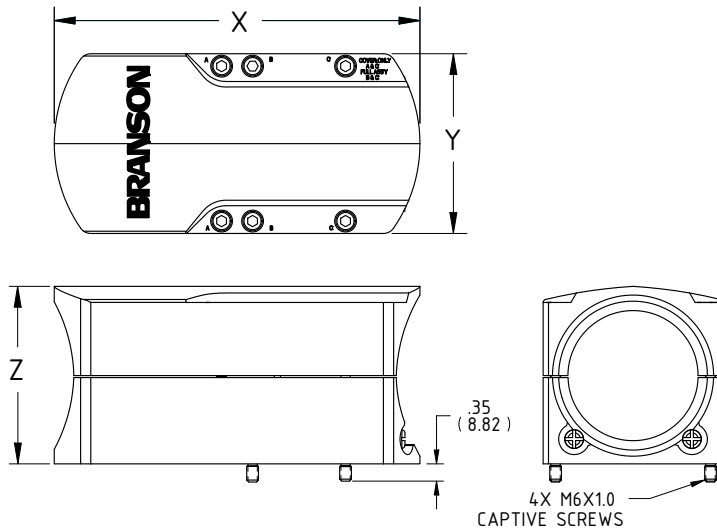

ORDERING INFORMATION:

Branson EDP No.

Acoustic Clamps

40 kHz	101-063-959
30 kHz	101-063-958
20 kHz	101-063-957

Note: All sales shall be subject to the Supplier's terms and conditions of sale as described in Branson's quotations and sales contracts.

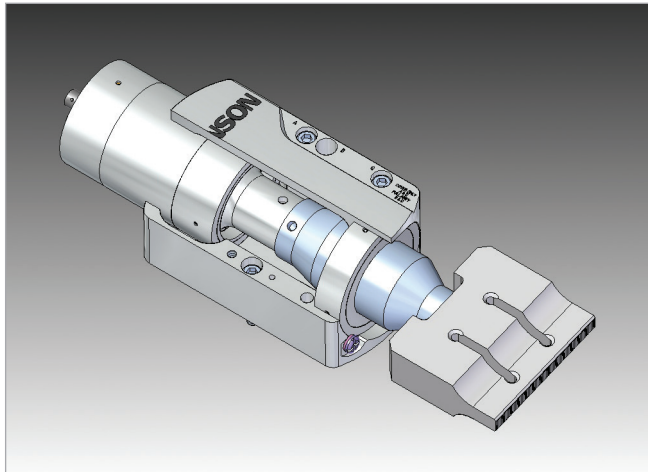

Converter Frequency	X	Y	Z	Weight
20 KHZ	7.38" (187.5 mm)	3.63" (92.1 mm)	3.58" (90.0 mm)	1,181 g
30 KHZ	5.50" (139.7 mm)	3.00" (76.2 mm)	3.00" (76.2 mm)	671 g
40 kHz	4.00" (101.6 mm)	2.19" (55.6 mm)	2.23" (56.5 mm)	334 g

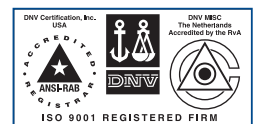

Americas

Branson Ultrasonics Corp.
41 Eagle Road
Danbury, CT 06813-1961
T: 800-796-0400
F: 203-796-9838
www.bransonultrasonics.com

Europe

Branson Ultraschall
Niederlassung der Emerson
Technologies GmbH & Co. OHG
Waldstrasse 53-55
63128 Dietzenbach, Germany
T: +49-6074-497-0
F: +49-6074-497-199
www.branson.eu

Asia

Branson Ultrasonics (Shanghai) Co., Ltd.
758 Rong Le Dong Road
Song Jiang, Shanghai, PRC, 201613
T: 86-21-3781-0588
F: 86-21-5774-5100
www.branson.com.cn