

BRANSON

DCX A and F Power Supplies

The Utmost In Control For Automation
Demands In Compact Space

Control, Performance, Flexibility in a Compact Power Supply

When your application requires automation, a high degree of control, and high-speed operating efficiency, Branson has the answer. Our DCX Series of power supplies provide the highest power density in the market today.

The DCX models A and F were specially developed for more advanced applications. They offer all the benefits of the DCX S but with enhanced weld parameter settings to achieve consistent weld quality through continuous system monitoring and closed-loop control of the welding process.

At the end of a weld cycle, the DCX A and F permit access to all relevant weld results for evaluation and documentation. The advanced communications capability and transparent information flow ensure that the DCX A and F can be integrated efficiently into a complex automated processing application.

The DCX F power supply includes the capability of being controlled and parameterized by a PLC over a Fieldbus network, providing real-time distributed control in an industrial network.



- **Enhanced flexibility via multiple weld modes** – The DCX A and F feature five different weld modes for meeting the needs of a variety of applications. The weld mode options include time, energy, peak power, ground detect, or continuous ultrasonic welding. At the end of a weld, the weld results can be reviewed to verify, evaluate, and document the weld. The user also can export the weld results to a spreadsheet for further analysis.
- **Increased process and automation control with limits and actuator I/O options** – The DCX A and F includes options for setting maximum and minimum reject limits for weld time, energy, and peak power. Also, the user can set a secondary weld cutoff limit for time, energy, or peak power.

The expanded I/O functionality of the DCX A and F allows the user to configure the DCX for use with an actuator. Actuator specific I/O inputs and outputs such as trigger and upper limit switch allow easy integration between the DCX and a stack actuating device.

- **Improved performance via closed-loop amplitude control** – The proven Digital Communication Platform with closed-loop amplitude control provides significant benefits in performance, consistency, and higher productivity, especially in applications requiring a high level of process control, weld quality, and high throughput.
- **User-friendly configuration and weld setup through Ethernet communications** – The Branson Global User Interface allows the user to interface with the DCX A and F power supplies via a standard Internet browser program such as Internet Explorer.

DCX F Fieldbus Capabilities

The DCX F features Fieldbus capabilities that allow real-time distributed control and communication with a PLC. This allows a PLC to configure the DCX F weld mode and parameters and to read back weld results and data in real time.

Fieldbus capability allows complex automated systems requiring multiple devices to be wired together in a single network. Using a single network, Fieldbus allows a programmable automation controller to monitor the status of an entire system, as well as communicate parameter changes to individual devices in real time.

The ability to network multiple devices significantly reduces the length and number of cables required, simplifies the integration of the PLC and other devices, and minimizes cabinet requirements.

Fieldbus Info

FIELDBUS INFO		COMMUNICATION SLATE	
Slave Address	192.168.10.100 <input type="radio"/> Alarm	<input checked="" type="radio"/> Ready	<input type="radio"/> Running
Data Formed	Intel Baud Rate N/A	<input checked="" type="radio"/> Bus On	<input type="radio"/> Configuration Locked
Slave Status	<input type="radio"/> Offline <input checked="" type="radio"/> Stop <input type="radio"/> Idle <input type="radio"/> Operate	<input type="radio"/> Parameter Fault	<input type="radio"/> Configuration Fault
CONTROL WORD		STATUS WORD	
BITS	7 6 5 4 3 2 1 0	BITS	7 6 5 4 3 2 1 0
STW1H	<input type="checkbox"/> <input type="checkbox"/> <input type="checkbox"/> <input type="checkbox"/> <input type="checkbox"/> <input type="checkbox"/> <input type="checkbox"/> <input type="checkbox"/>	ZBW1H	<input type="checkbox"/> <input type="checkbox"/> <input type="checkbox"/> <input type="checkbox"/> <input type="checkbox"/> <input type="checkbox"/> <input type="checkbox"/> <input type="checkbox"/>
STW1L	HFS1 HFS2 HFS1 HFS2 RES ES RES	ZBW1L	LS1 LM PS1 PS2 HFS1 HFS2 TEE ES NO-B
STW2H	RES RES APPRO SMOOT RES RES ON RES	ZBW2H	HFS3 HFS2 HFS1 HFS2 HFS1 TEE ES NO-B
STW2L	RES RES APPRO SMOOT RES RES ON RES	ZBW2L	RES RES LM CK ON OFF SM TP-B
	RES RES RES SP2E SP2T SP2D SP2T PCT	ZBW3L	LS1 WPA OF-B RCTP USB WPA-DMS SEL2

EMERSON
Industrial Automation

DCX F Global User Interface allows real-time diagnostic analysis of Fieldbus communication between the DCX F and a PLC.

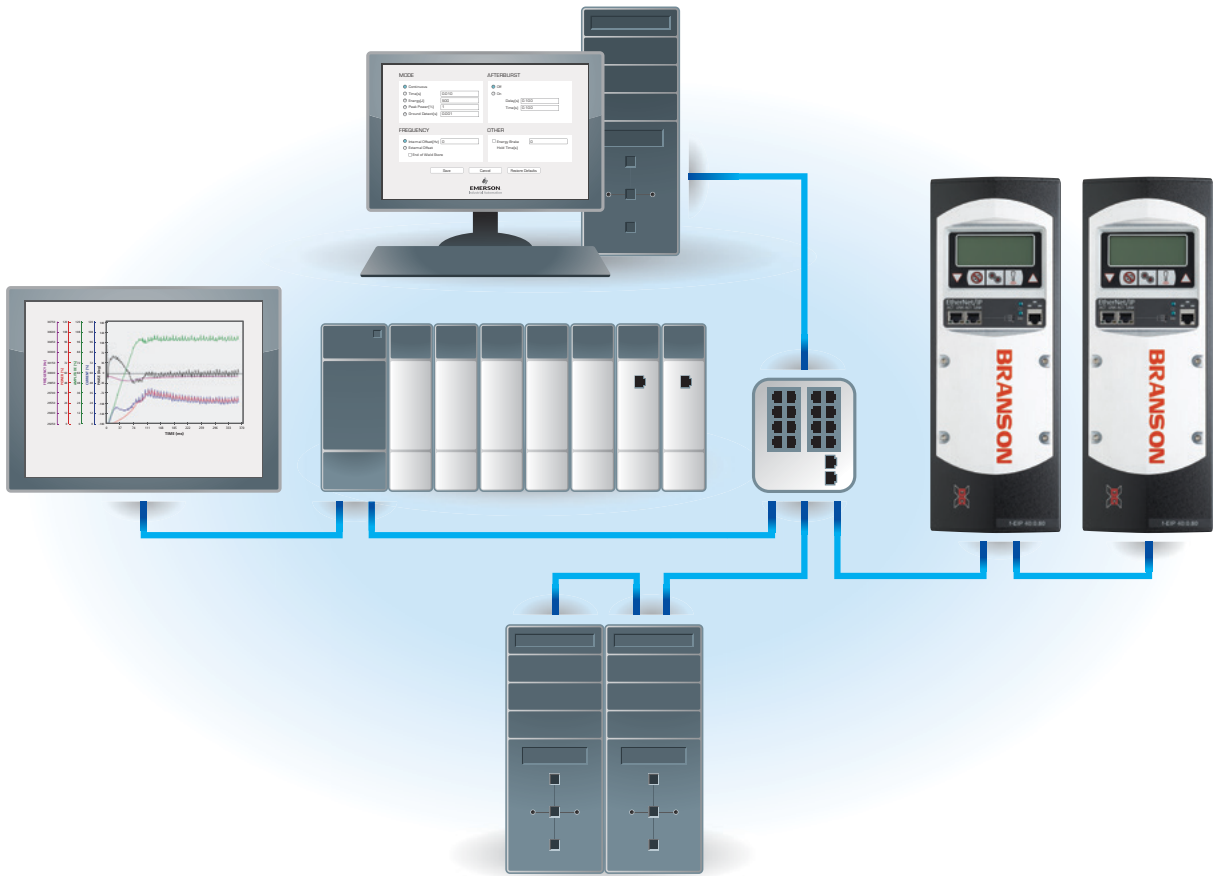

Key Features

- Digital Amplitude Control** – The DCX A and F offer digital amplitude control through the LCD user interface, the Branson Global User Interface, or from a user-provided external source. The amplitude rate and level can be adjusted instantaneously during a weld to increase weld energy, decrease the weld time, and increase product throughput (Fig. 1).
- Regulation** – The closed-loop amplitude control maintains accurate output amplitude by correcting for disturbances in line voltage (Fig. 2) and output power loading (Fig. 3). Constant amplitude control also requires less force to deliver output power, which results in greater weld consistency, less flash, and less deflection of thin-walled parts.
- Autotune Plus Memory (AT/M)** – AT/M provides fully-automatic tuning within a range of ± 500 Hz for 20 kHz horns, ± 750 Hz for 30 kHz horns, and ± 1000 Hz for 40 kHz horns.
- Auto Seek** – The Auto Seek function tracks the operating frequency of the stack by oscillating the horn at a low-level amplitude (10%) and storing the operating frequency in the DCX controller's memory.
- Scan** – The scan ensures reliable horn starting by performing a full-frequency analysis of the horn's operating band and storing the primary operating frequency in the DCX controller's memory.
- Programmable Starting Ramp Times** – The ultrasonic starting rate can be programmed from 1 to 999 milliseconds to accommodate the starting characteristics of a wide variety of horns.
- Front Panel Interface** – The icon-driven interface allows the user to read and set weld parameters, perform horn tests, configure the DCX weld settings, and clear alarms.
- I/O Interface** – I/O status outputs and command inputs are programmable through the Branson Global User Interface and are accessible through the 26-pin D-shell port.
- Power Measurement** – Real output RF power to the horn is displayed on the front panel LCD screen and is accessible through the I/O port in a relative 0-10V analog output signal.

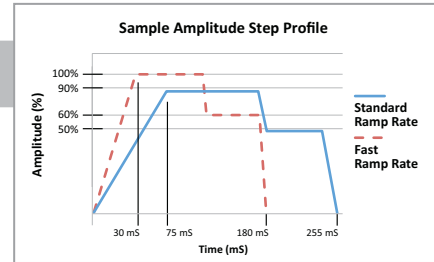

Figure 1

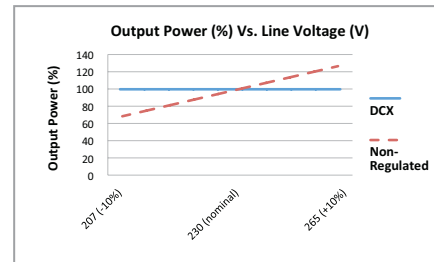

Figure 2

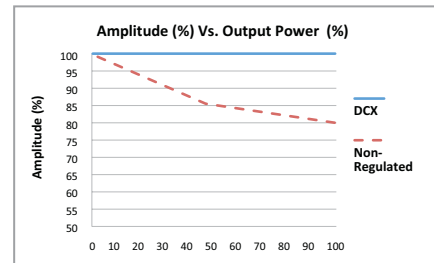

Figure 3

- Enclosure Design** – The DCX comes in a vertical, horizontal, and rack mount industrial enclosure. The vertical enclosure allows mounting in industrial automation cabinets. The horizontal enclosure allows mounting on bench tops or shelves. The rack mount enclosure is for mounting in a 19" drawer. Thermal management of the internal components in the DCX horizontal and vertical is accomplished through a cooling channel, which separates the electronics from the air flow. The DCX rack mount requires a separate rack mount fan unit for cooling.
- System Protection Monitor (SPM)** – The SPM continually evaluates the DCX operating conditions to protect the power supply, converter, and other system components from failures and downtime.
- High Cycle Rate** – Cycle rates are dependent on application and control requirements but are capable in excess of 200 welds per minute.

Branson Global User Interface

The DCX A and F offer a powerful web-based interface that comes standard on all DCX Power Supplies. This eliminates costly software and dedicated computer hardware that often lead to a loss of productivity and time.

The Branson Global User Interface uses a standard HTML-based communication interface protocol. This allows the user to employ a commercially available Internet browser and Ethernet cable to set weld presets and system configurations, monitor performance, customize I/O configurations, perform system diagnostics, and many other functions. The interface offers a tab structure for simple navigation.

Weld History

Cycle #	Date & Time	Weld Mode	Weld Time	Weld Energy	Peak Power	Amp 1	Amp 2	Preset No	Start Freq
424	08-14-13 05:34:17 PM	Energy	01.029	1803	60	100	N/A	0	19960
423	08-14-13 05:34:15 PM	Energy	01.035	1803	57	100	N/A	0	19962
422	08-14-13 05:34:13 PM	Energy	01.009	1802	57	100	N/A	0	19963
421	08-14-13 05:34:11 PM	Energy	01.017	1802	58	100	N/A	0	19962
420	08-14-13 05:34:09 PM	Energy	01.037	1802	58	100	N/A	0	19962
419	08-14-13 05:34:07 PM	Energy	01.003	1802	57	100	N/A	0	19963
418	08-14-13 05:34:06 PM	Energy	00.999	1803	58	100	N/A	0	19964
417	08-14-13 05:32:40 PM	Time	01.025	1842	59	100	N/A	0	19965
416	08-14-13 05:32:37 PM	Time	01.025	1835	57	100	N/A	0	19964
415	08-14-13 05:32:35 PM	Time	01.025	1780	57	100	N/A	0	19966
414	08-14-13 05:32:34 PM	Time	01.025	1861	58	100	N/A	0	19966
413	08-14-13 05:32:32 PM	Time	01.025	1830	59	100	N/A	0	19966
412	08-14-13 05:32:30 PM	Time	01.025	1815	57	100	N/A	0	19968

Enables the user to verify, evaluate and document the weld results. The weld results can be exported to a spreadsheet for further analysis.

Horn Signature and Diagnostics

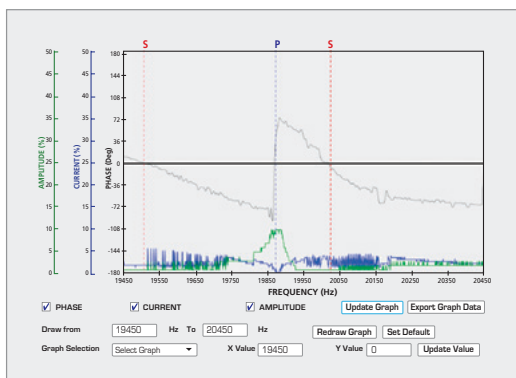

Allows for viewing and documenting the horn characteristics after a broadband frequency scan. The scan graphically displays the horn's characteristics and reports the parallel and series resonant frequencies.

Weld Setup

MODE

Continuous

Time(s)

Energy(J)

Peak Power(%)

Ground Detect(s)

AFTERBURST

Off

On

Delay(s)

Time(s)

FREQUENCY

Internal Offset(Hz)

External Offset

End of Weld Store

OTHER

Energy Brake

Hold Time(s)

Allows for setup of the weld mode in time, energy, peak power, ground detect or continuous ultrasonic.

Weld Graph

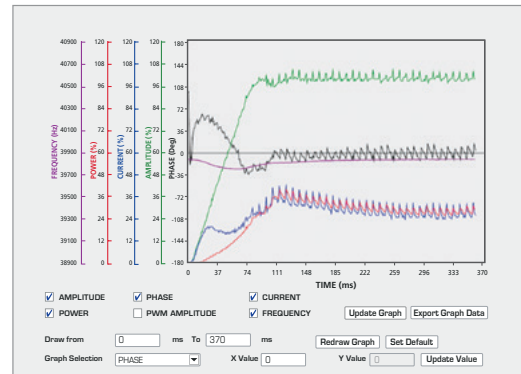

Displays graphing of the weld data in 1 ms increments. The weld graph data includes power, frequency, and amplitude. The weld graph data also can be exported to a spreadsheet.

Configuration – User I/O

DIGITAL INPUTS

J3-1 STD-External Start 0 V 24 V

J3-2 UNASSIGN 0 V 24 V

J3-3 ACT-Actuator Present

J3-4 ACT-Cycle Abort

J3-5 ACT-Ground Detect

J3-6 ACT-Interlock in Place

J3-7 ACT-Part In Place

J3-8 ACT-Trigger Switch

J3-9 ACT-Upperlimit Switch

J3-10 RF-Feedback 1

J3-11 RF-Feedback 2

J3-12 RF-Feedback 4

J3-13 RF-Feedback B

J3-14 STD-Status Feedback

J3-15 STD-Cable Detect

J3-16 STD-Display Lock

J3-17 STD-External A...

J3-18 STD-External Ho...

J3-19 STD-External Reset

J3-20 STD-External Seek

J3-21 STD-External Sto...

J3-22 STD-External Start

J3-23 STD-External Test

J3-24 STD-External Test

DIGITAL OUTPUTS

J3-7 STD-Ready 0 V 24 V

J3-8 STD-Sonics Active 0 V 24 V

J3-9 STD-General Alarm 0 V 24 V

J3-10 STD-STD-Seek/Scan 0 V 24 V

J3-19 STD-Amp1 Amp2 0 V 24 V

J3-20 STD-Overload Alarm 0 V 24 V

Enables configuration of all digital and analog I/O functions. The I/O configuration includes functions such as power monitoring, amplitude control, acoustic starting control, and seek.

DCX A and F Series Specifications – Horizontal & Vertical

Three Power Supply Sizes

Size	Small			Medium		Large	
DCX A/F	40:0.4	30:0.75	40:0.8	20:1.25	30:1.5	20:2.5	20:4.0
Frequency	40 kHz	30 kHz	40 kHz	20 kHz	30 kHz	20 kHz	20 kHz
Peak Output Power	400 W	750 W	800 W	1250 W	1500 W	2500 W	4000 W
Max. Continuous Power	200 W	375 W	400 W	625 W	750 W	1250 W	2000 W
Circuit Breaker	10 A	10 A	10 A	15 A	15 A	25 A	25 A
Supply Voltage	180-253 VAC, 50/60 Hz, 1 PH, 24 V DC, 3A			180-253 VAC, 50/60 Hz, 1 PH, 24 V DC, 3A		180-253 VAC, 50/60 Hz, 1 PH, 24 V DC, 3A	
Weight	16 lbs. / 7.25 kg			18 lbs. / 8.16 kg		22 lbs. / 10 kg	

Dimensions

Dimension	Inch	mm
a	10.63	270.0
b	8.63	219.2
c	7.13	181.1
d	5.53	140.5
e	14.01	355.9
f	0.37	9.4
g	17.38	441.5
h	5.22	132.6
i	4.50	114.3
j	3.50	88.9
k	15.75	400.0
l	3.37	85.6
m	2.37	60.2
n	1.06	26.9

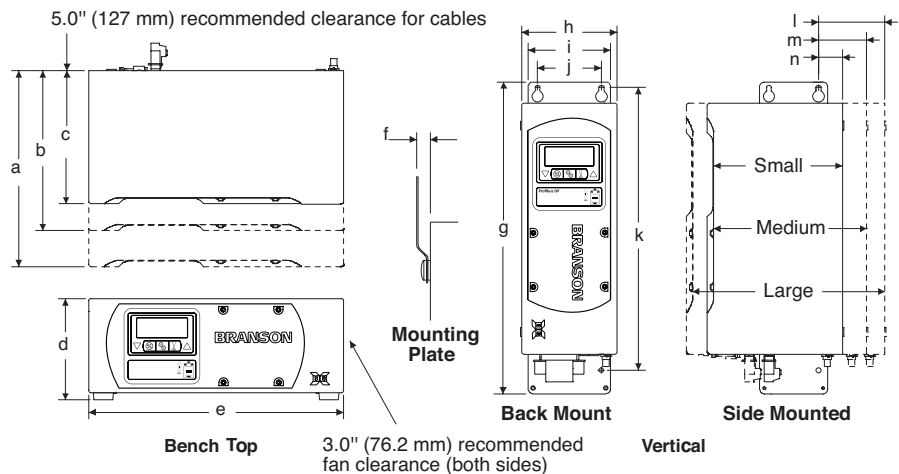

Ordering Key

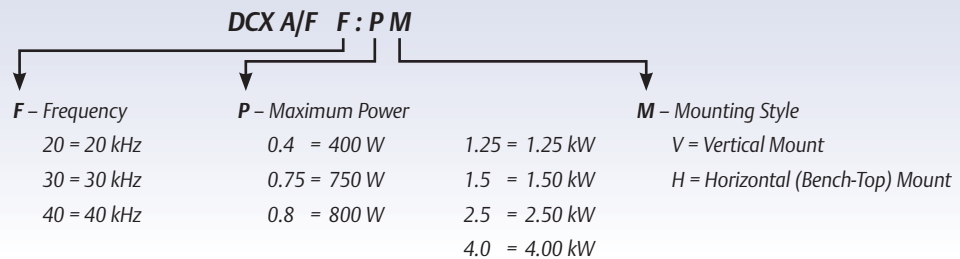

DCX A and F Series Specifications – Rack Mount

Three Power Supply Sizes

Size	Small		Medium		Large
DCX A/F	40:0.8	30:1.5	20:1.25	20:2.5	20:4.0
Frequency	40 kHz	30 kHz	20 kHz	20 kHz	20 kHz
Peak Output Power	800 W	1500 W	1250 W	2500 W	4000 W
Max. Continuous Power	400 W	750 W	625 W	1250 W	2000 W
Fuse	16 A	16 A	16 A	16 A	25 A
Supply Voltage	180-253 VAC, 50/60 Hz, 1 PH, 24 V DC, 3A		180-253 VAC, 50/60 Hz, 1 PH, 24 V DC, 3A		200-253 VAC, 50/60 Hz, 1 PH, 24 V DC, 3A
Weight	8 lbs. / 3.6 kg		12 lbs. / 5.4 kg		15 lbs. / 6.8 kg

Dimensions

Dimension	Units	mm
a	3 HE	128
b	21 TE	106
c	28 TE	142
d	42 TE	213
e	—	450

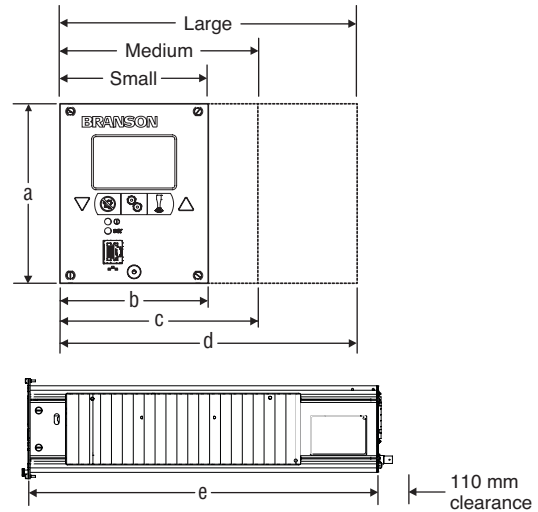

Ordering Key

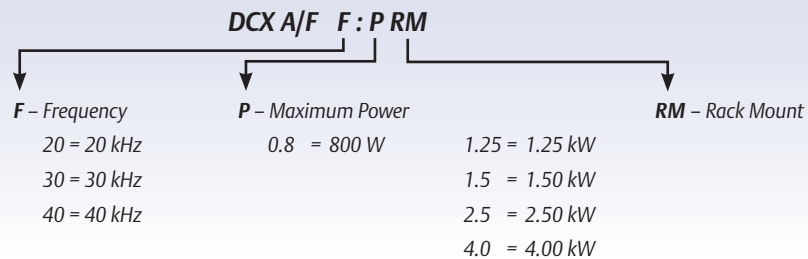

True Global Support & Service

Branson Ultrasonics is the world leader in materials joining, with more than 1,800 employees and 70 sales and support offices. We are committed to leading the industry in products, solutions, service, and support excellence. That means fast delivery, troubleshooting, parts replacement, feasibility studies, cooperative research, preventative maintenance, and repair services. Branson is part of the Industrial Automation division of Emerson, a diversified international manufacturing and technology company committed to developing technological breakthroughs that advance the performance of a wide range of products and processes.

All specifications subject to change without notice. All dimensions are nominal.
All units are CE compliant and comply with FCC rules and regulations governing radio frequency interference.



Americas

Branson Ultrasonics Corp.
41 Eagle Road
Danbury, CT 06810, USA
T: 203-796-0400
F: 203-796-0450
www.bransonultrasonics.com

Europe

Branson Ultraschall
Niederlassung der Emerson
Technologies GmbH & Co. OHG
Waldstrasse 53-55
63128 Dietzenbach, Germany
T: +49-6074-497-0
F: +49-6074-497-199
www.branson.eu

Asia

Branson Ultrasonics (Shanghai) Co., Ltd.
758 Rong Le Dong Road
Song Jiang, Shanghai, PRC, 201613
T: 86-21-3781-0588
F: 86-21-5774-5100
www.branson.com.cn