2000X ao Actuator Instruction Manual

EDP 100-214-281

Rev. 07

Software Version 10.xx and above

BRANSON Ultrasonics Corporation
41 Eagle Road
Danbury, Connecticut 06813-1961 U.S.A.
(203) 796-0400

Manual Change Information

At Branson, we strive to maintain our position as the leader in ultrasonics plastics joining, cleaning and related technologies by continually improving our circuits and components in our equipment. These improvements are incorporated as soon as they are developed and thoroughly tested.

Information concerning any improvements will be added to the appropriate technical documentation at its next revision and printing. Therefore, when requesting service assistance for specific units, note the Revision information found on the cover of this document, and refer to the printing date which appears at the bottom of this page.

Copyright



NOTE

Loctite is a registered trademark of Henkel Corporation U.S.A. Other trademarks and service marks mentioned herein are held by their respective owners.

2000X ao Actuator Instruction Manual

Foreword

Congratulations on your choice of a Branson Ultrasonics Corporation system!

The Branson 2000X-Series system is process equipment for the joining of plastic parts using ultrasonic energy. It is the newest generation of product using this sophisticated technology for a variety of customer applications. This Instruction Manual is part of the documentation set for this system, and should be kept with the equipment.

Thank you for choosing Branson!

Introduction

This manual is arranged into several structured chapters which will help you find the information you may need to know to safely handle, install, set up, program, operate, and/or maintain this product. Please refer to the Table of Contents and/or the Index of this manual to find the information you may be looking for. In the event you require additional assistance or information, please contact our Product Support department (Chapter 1, see [How to Contact Branson on page 1-10](#) for information on how to contact them) or your local Branson representative.

Table of Contents

- 1 Safety and Support**
 - 1.1 Safety Requirements and Warnings** - - - - - 1-2
 - 1.1.1 Symbols Found in this Manual - - - - - 1-2
 - 1.1.2 Symbols Found on the Product - - - - - 1-2
 - 1.2 General Precautions** - - - - - 1-3
 - 1.2.1 Intended Use of the System - - - - - 1-5
 - 1.2.2 Safety Measures and Guards- - - - - 1-6
 - 1.2.3 Emissions - - - - - 1-6
 - 1.2.4 Setting up the Workplace- - - - - 1-6
 - 1.2.5 Regulatory Compliance - - - - - 1-6
 - 1.3 Warranty Statement, Disclaimer** - - - - - 1-6
 - 1.4 How to Contact Branson** - - - - - -1-10
 - 1.4.1 Before Calling Branson for Assistance - - - - - -1-10
 - 1.5 Returning Equipment for Repair** - - - - - -1-11
 - 1.5.1 Get an RGA Number - - - - - -1-12
 - 1.5.2 Record information about the Problem - - - - - -1-12
 - 1.5.3 Departments to Contact - - - - - -1-13
 - 1.5.4 Pack and Ship the Equipment - - - - - -1-14
 - 1.6 Obtaining Replacement Parts-** - - - - - -1-14

- 2 Introduction to the 2000X ao Actuator**
 - 2.1 Models Covered-** - - - - - 2-1
 - 2.1.1 Power Supply Manual Set - - - - - 2-2
 - 2.1.2 Actuator Manual Set - - - - - 2-3
 - 2.2 Overview of this Model** - - - - - 2-3
 - 2.3 Features of the System** - - - - - 2-4
 - 2.4 Controls and Indicators-** - - - - - 2-7
 - 2.5 Welding Systems** - - - - - 2-8
 - 2.6 Glossary of Terms** - - - - - -2-10

- 3 Delivery and Handling**
 - 3.1 Shipping and Handling** - - - - - 3-1

3.1.1	Environmental Specifications - - - - -	3-1
3.2	Receiving - - - - -	3-2
3.3	Unpacking - - - - -	3-3
3.3.1	Actuator Assemblies - - - - -	3-3
3.4	Returning Equipment - - - - -	3-3
4	Installation and Setup	
4.1	About Installation - - - - -	4-2
4.2	Handling and Unpacking - - - - -	4-2
4.2.1	Unpack the Stand or Actuator - - - - -	4-3
4.2.2	Stand (actuator on a base) - - - - -	4-3
4.2.3	Stand (Actuator on a Hub) - - - - -	4-5
4.2.4	Actuator (Alone) - - - - -	4-6
4.3	Take Inventory of Small Parts - - - - -	4-7
4.3.1	Cables - - - - -	4-8
4.4	Installation Requirements - - - - -	4-9
4.4.1	Location - - - - -	4-9
4.4.2	Environmental Specifications - - - - -	4-9
4.4.3	Electrical Input Power Ratings - - - - -	4-10
4.4.4	Air Cylinder Consumption - - - - -	4-11
4.4.5	Factory Air - - - - -	4-15
4.5	Installation Steps - - - - -	4-16
4.5.1	Mounting the Stand (Actuator on Base) - - - - -	4-16
4.5.2	Mounting the Stand (Actuator on Hub-mounted column)- - - - -	4-17
4.5.3	Actuator (Alone) - - - - -	4-18
4.5.4	Mount the Power Supply - - - - -	4-20
4.5.5	Input Power (Main)- - - - -	4-21
4.5.6	Output Power (RF Cable) - - - - -	4-21
4.5.7	Interconnect between Power Supply and Actuator - - - - -	4-21
4.5.8	Start Switch Connection (Automation) - - - - -	4-23
4.5.9	Serial (RS-232) Port Connector- - - - -	4-24
4.5.10	Parallel Printer Connector - - - - -	4-24
4.5.11	User I/O Interface - - - - -	4-24
4.5.12	Input Power Plug- - - - -	4-27
4.5.13	User I/O DIP Switch (SW1)- - - - -	4-28
4.5.14	Module Options DIP Switch - - - - -	4-28
4.6	Guards and Safety Equipment - - - - -	4-29
4.6.1	Emergency Stop Control - - - - -	4-29

- 4.7 Rack Mount Installation** - - - - -4-29
- 4.8 Assemble the Acoustic Stack** - - - - -4-31
 - 4.8.1 For a 20kHz System - - - - -4-31
 - 4.8.2 For a 30kHz System - - - - -4-32
 - 4.8.3 For a 40kHz System - - - - -4-32
 - 4.8.4 Assembling the 20kHz Acoustic Stack - - - - -4-33
 - 4.8.5 Connecting Tip to Horn- - - - -4-34
 - 4.8.6 Installing the Stack in the Actuator - - - - -4-35
- 4.9 Mounting the Fixture on the Branson Base**- - - - -4-37
- 4.10 Testing the Installation** - - - - -4-38
- 4.11 Still Need Help?**- - - - -4-39

- 5 Technical Specifications**
 - 5.1 Technical Specifications** - - - - - 5-1
 - 5.1.1 Requirement Specifications - - - - - 5-1
 - 5.1.2 Performance Specifications - - - - - 5-2
 - 5.2 Physical Description** - - - - - 5-3
 - 5.2.1 Standard Items- - - - - 5-3

- 6 Operation**
 - 6.1 Actuator Controls**- - - - - 6-1
 - 6.2 Initial Actuator Settings**- - - - - 6-2
 - 6.2.1 Regulated Air Pressure and Air Pressure Gauge - - - - - 6-2
 - 6.2.2 Factory Air Source - - - - - 6-3
 - 6.2.3 Downspeed Control - - - - - 6-3
 - 6.2.4 Dynamic Trigger - - - - - 6-3
 - 6.2.5 Actuator Alignment and Height (Horn travel) - - - - - 6-4
 - 6.2.6 Mechanical Stop - - - - - 6-4
 - 6.2.7 Emergency Stop - - - - - 6-5
 - 6.3 Operating the Actuator**- - - - - 6-5

- 7 Maintenance**
 - 7.1 Calibration** - - - - - 7-1
 - 7.2 Periodic and Preventive Maintenance** - - - - - 7-1
 - 7.2.1 Periodically Clean the Equipment- - - - - 7-1
 - 7.2.2 Recondition the Stack (converter, booster, and horn) - - - - 7-2
 - 7.2.3 Routine Component Replacement - - - - - 7-4
 - 7.3 Parts Lists** - - - - - 7-5

Index

List of Figures

fig. 1.1	Connector label on the ao Actuator - - - - -	1-2
fig. 1.2	Caution label on the aod Actuator for the factory air supply - - - - -	1-3
fig. 1.3	Safety Labels on front of the aod Actuator - - - - -	1-3
fig. 2.1	Right Side View of the 2000X ao Actuator - - - - -	2-2
fig. 4.1	Unpacking the Stand (Actuator on a Base); Right-side View of Stand - - - - -	4-3
fig. 4.2	Unpacking the Stand (Actuator on a Hub); Hub Shown Separately - - - - -	4-5
fig. 4.3	Ultrasonic Converter (J-Type for Stand-Alone Use) and Booster - - - - -	4-6
fig. 4.4	Power Supply Dimensional Drawing - - - - -	4-12
fig. 4.5	ao Actuator Dimensional Drawing - - - - -	4-13
fig. 4.6	Block Wiring Diagram - - - - -	4-14
fig. 4.7	Base Mounting Centers - - - - -	4-17
fig. 4.8	Mounting Bolt Pattern for the Hub (for Stand on Hub)- - - - -	4-18
fig. 4.9	Rear view of Actuator, showing Mounting Surface, Bolt and Guide Pin locations - - - - -	4-19
fig. 4.10	Connections on Rear of Power Supply - - - - -	4-20
fig. 4.11	Electrical Connections from Power Supply to a 2000-series Actuator - - - - -	4-22
fig. 4.12	Start Switch Connection Codes - - - - -	4-23
fig. 4.13	User I/O Cable Identification and Wire Color Diagram - - - - -	4-24
fig. 4.14	Line Cord Color Code - - - - -	4-27
fig. 4.15	Actuator Emergency Stop Button - - - - -	4-29
fig. 4.16	Detail of Rack Mount Handle Kit Assembly - - - - -	4-30
fig. 4.17	Assembling the 20kHz Acoustic Stack - - - - -	4-33
fig. 4.18	Connecting Tip to Horn - - - - -	4-34
fig. 4.19	Installing a 20kHz Stack in a Branson Actuator - - - - -	4-35
fig. 4.20	Installing a 40kHz Stack in a Branson Actuator - - - - -	4-36
fig. 4.21	Mounting Circles on Base - - - - -	4-37
fig. 4.22	Normal Front Panel Display After Power-Up - - - - -	4-38
fig. 5.1	2000 Actuator Pneumatic Schematic - - - - -	5-5

List of Tables

tab. 1 .1	Warranty Period - - - - -	1-8
tab. 1.2	Branson Contacts - - - - -	1-13
tab. 3.1	Environmental Specifications - - - - -	3-1
tab. 4.1	Small Parts included (=x) with Power Supply and/or Actuator Assemblies	4-7
tab. 4.2	List of Cables - - - - -	4-8
tab. 4.3	Environmental Specifications - - - - -	4-9
tab. 4.4	Input Power requirements - - - - -	4-10
tab. 4.5	User I/O Cable Pin Assignments. - - - - -	4-25
tab. 4.6	User I/O Input and Output Function Selection - - - - -	4-27
tab. 4.7	User I/O DIP Switch Functions - - - - -	4-28
tab. 4.8	Tools - - - - -	4-31
tab. 4.9	Stud Torque Values - - - - -	4-34
tab. 4.10	Tip to Horn Torque Specifications - - - - -	4-34
tab. 5.1	Environmental Specifications - - - - -	5-1
tab. 5.2	Max. welding force, dynamic trigger force, dynamic follow-through - - -	5-2
tab. 5.3	Maximum Traverse Speed (Application dependant)- - - - -	5-2
tab. 5.4	Description of Controls on Base - - - - -	5-3
tab. 7.1	Component Replacements Based on Cycles Run - - - - -	7-4
tab. 7.2	Accessories List for ao Actuator - - - - -	7-5
tab. 7.3	Spare Parts List for the aoActuator- - - - -	7-8
tab. 7.4	Suggested Spares- - - - -	7-9

Chapter 1: Safety and Support

- 1.1 Safety Requirements and Warnings** - - - - - 1-2
- 1.1.1 Symbols Found in this Manual - - - - - 1-2
- 1.1.2 Symbols Found on the Product - - - - - 1-2
- 1.2 General Precautions** - - - - - 1-3
- 1.2.1 Intended Use of the System - - - - - 1-5
- 1.2.2 Safety Measures and Guards - - - - - 1-5
- 1.2.3 Emissions - - - - - 1-6
- 1.2.4 Setting up the Workplace - - - - - 1-6
- 1.2.5 Regulatory Compliance- - - - - 1-6
- 1.3 Warranty Statement, Disclaimer** - - - - - 1-7
- 1.4 How to Contact Branson** - - - - - 1-10
- 1.4.1 Before Calling Branson for Assistance - - - - - 1-10
- 1.5 Returning Equipment for Repair** - - - - - 1-11
- 1.5.1 Get an RGA Number - - - - - 1-12
- 1.5.2 Record information about the Problem - - - - - 1-12
- 1.5.3 Departments to Contact - - - - - 1-13
- 1.5.4 Pack and Ship the Equipment - - - - - 1-14
- 1.6 Obtaining Replacement Parts-** - - - - - 1-14

This chapter contains an explanation of the different Safety Notice symbols and icons found both in this manual and on the product itself and provides additional safety information for ultrasonic welding. This chapter also describes how to contact Branson for assistance.

1.1 Safety Requirements and Warnings

1.1.1 Symbols Found in this Manual

Three symbols used throughout this manual warrant special attention:



NOTE

A Note contains important information. It does not alert the user to potential injury, but only to a situation that might eventually require additional work or modification if you ignore it initially.



CAUTION

A Caution indicates a potentially hazardous situation that, if not avoided, can result in minor or moderate injury. It might also alert the user to unsafe practices or conditions that can damage equipment if not corrected.



WARNING

A Warning indicates a hazardous situation or practice that, if not avoided, can result in serious injury or death.

1.1.2 Symbols Found on the Product

Familiar graphic warning symbols are used to alert the user to items of concern or hazard. The following warning symbols appear on the 2000X ao Actuator

Figure 1.1 Connector label on the ao Actuator

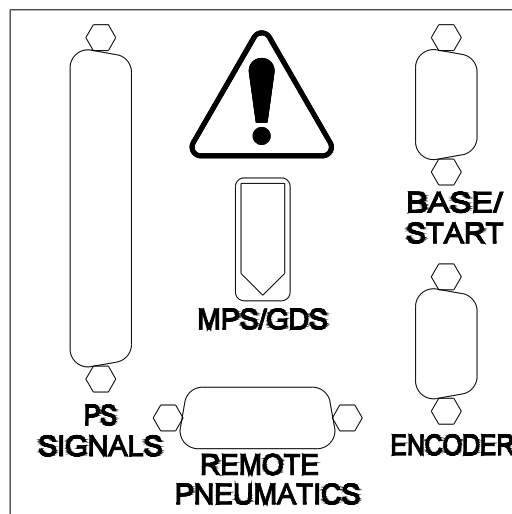
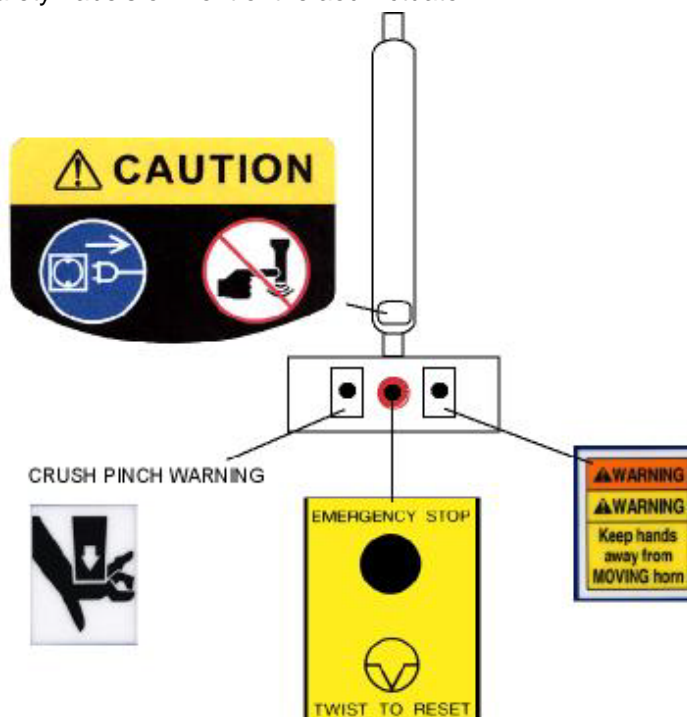

Figure 1.2 Caution label on the aod Actuator for the factory air supply



Figure 1.3 Safety Labels on front of the aod Actuator



1.2 General Precautions

Take the following precautions before servicing the power supply:

- Be sure the power switch is in the Off position before making any electrical connections.
- To prevent the possibility of an electrical shock, always plug the power supply into a grounded power source.
- Power supplies produce high voltage. Before working on the power supply module, do the following:
 - Turn off the power supply;
 - Unplug main power; and
 - Allow at least 2 minutes for capacitors to discharge.
- High voltage is present in the power supply. Do not operate with the cover removed.
- High line voltages exist in the ultrasonic power supply module. Common points are tied to

circuit reference, not chassis ground. Therefore, use only non-grounded, battery-powered multimeters when testing these modules. Using other types of test equipment can present a shock hazard.

- Be sure power is disconnected from the power supply before setting a DIP switch.
- Keep hands from under the horn. Down force (pressure) and ultrasonic vibrations can cause injury.
- Do not cycle the welding system if either the RF cable or converter is disconnected.
- When using larger horns, avoid situations where fingers could be pinched between the horn and the fixture.
- Be aware that the actuator is "armed" if the pressure indicator light on the front panel is on.
- Be aware that the actuator is "armed" if air pressure is indicated by the pressure indicator on the actuator front panel and/or the air pressure gauge in the remote box.
- In normal operation, bearing seals will retain an adequate amount of grease for safe bearing operation. Bearing can leak but contains enough grease for the life of the bearing. Removing and running without grease will void the warranty. For more information contact product support.



NOTE

Sound level and frequency of the noise emitted during the ultrasonic assembly process may depend upon a. type of application, b. size, shape and composition of the material being assembled, c. shape and material of the holding fixture, d. welder setup parameters and e. tool design. Some parts vibrate at an audible frequency during the process. Some or all of these factors may result in an uncomfortable noise being emitted during the process. In such cases operators may need to be provided with personal protective equipment. See 29 CFR (Code of Federal Regulations) 1910.95 Occupational Noise Exposure.

Manufacturers of Protective Materials and Equipment	
Hearing Protectors	
Safeware, Inc 9475 Lottsford Rd. Suite 150 Largo, MD 20774-5351 www.safewareinc.com	David Clark 360 Franklin St. Box 15054 Worcester, MA 01615-0054 www.davidclark.com

Softcomm Products 2310 - T South Airport Blvd. Chandler, AZ 85224	Elvex Corp 13 Trowbridge Drive Bethel, CT 06801
Sound Absorbing Material	
American Acoustical Products 6 October Hill Road Holliston, MA 01746	Tamer Industries 185 Riverside Av. Somerset MA 02725
Singer Safety Co. 2300 W. Logan Blvd. Chicago IL 60647-2023	Foamex 1501 E. Second St. Eddystone PA 19022
Polymer Technologies, Inc. 420 - T Corporate Blvd. Newark, DE 19702	Soundcoat Company 1 Burt Drive Deer Park, NY 11729
Static Protection Equipment	
Polygenex PO Box 4468 Cary, NC 27519	Electrostatics, Inc. 352D Godshall Dr. Harleysville, PA 19438-2017
Terra Universal 700 - N Harbor Blvd. Anaheim, CA 92805 www.terrauni.com	

1.2.1 Intended Use of the System

The 2000X-series Power Supply and ao Actuator are components of an ultrasonic welding system. These are designed for a wide variety of welding or processing applications.

1.2.2 Safety Measures and Guards

The 2000X ao Actuator, along with its 2000X-Series Power Supply, contains software-controlled electronic safety devices intended to prevent the machine from operating in a fashion harmful to the user. Start Switch and Emergency Stop controls are designed to prevent undesirable startup.

1.2.3 Emissions

When being processed, certain plastic materials can emit toxic fumes, gases or other emissions that can be hazardous to the operator's health. Where such materials are processed, proper ventilation of the workstation is required. Check your materials suppliers for recommended protection when processing their materials.



CAUTION

Processing of many materials, such as PVC, can be hazardous to an operator's health and could cause corrosion/damage to the equipment. Use proper ventilation and take protective measures.

1.2.4 Setting up the Workplace

Measures for setting up a workplace for safe operation of the ultrasonic welder are outlined in *Chapter 4: Installation and Setup* and in the 2000 Series Installation Guide.

1.2.5 Regulatory Compliance

This product meets electrical safety requirements and EMC (Electromagnetic Compliance) requirements for North America and the European Union.

1.3 Warranty Statement, Disclaimer

The following excerpts from the "Terms and Conditions of Sale" (found on the back of your Invoice) are essential guidelines for the product Warranty issued with your Branson ultrasonic welding components. The items listed in this section specifically address issues involving the delivery, shipment, and warranty period provided. If you have any questions, please refer to the back of the Invoice included with your system, which lists all of the Terms and Conditions of Sale, or contact your Branson representative.

TERMS AND CONDITIONS OF SALE

Branson Ultrasonics Corporation is herein referred to as the “Seller” and the customer or person or entity purchasing products (“Products”) from Seller is referred to as the “Buyer.” Buyer’s acceptance of the Products will manifest Buyer’s assent to these Terms and Conditions.

ULTRASONIC JOINING EQUIPMENT NORTH AMERICAN WARRANTY POLICY

Each product manufactured by Branson is guaranteed to be free from *defects in material and workmanship* for a period of time specified in [Table 1.1 Warranty Period](#) from the date of invoice.

Table 1.1 *Warranty Period*

Power Supplies	36 months
Actuators	36 months
Integrated Welders	36 months
Accessories	36 months
Converters	36 months (limited to <i>one-time</i> replacement)
Non-Branson equipment (i.e. printers)	warranted by the manufacturer
Horns	12 months (limited to <i>one-time</i> replacement)
Boosters	36 months
Rental Equipment	Same as purchased equipment
Specials and products with EDP prefix 159-xxx-xxx	12 months
Specials and products with EDP prefix 125-xxx-xxx	12 months

The warranty does *not* apply to:

- any product which has been subject to misuse, misapplication, neglect (including without limitation inadequate maintenance), accident or improper installation, modification or adjustment.
- applications requiring metal-to-metal contact when the ultrasonic exposure time exceeds 1.5 seconds.
- any product exposed to adverse environments, improper repair or repairs using non-Branson methods or material.
- non-Branson equipment (i.e., horns, boosters, converters) or improperly tuned horns.
- Set up/installation of equipment and software updates.

Warranty Service covers the following:

Repair service at Branson's main repair facility or a regional office

- Includes parts and labor performed at Branson authorized repair facilities. The customer must return the equipment properly packed with all shipping charges prepaid.

Repair service at the customer site

- Includes parts and labor at the customer site performed by a Branson technician. The customer is responsible for all travel-related charges.

Module trade-in:

- Includes serialized components for work performed by the customer. The customer orders the replacement components from the Parts Store and issues a P.O. When the failed components are returned to Branson the warranty status is verified and a credit is issued. The customer is responsible for all shipping charges.

Additional Warranty Notes

- Components replaced during in-warranty repair carries the remainder of the original warranty.
- Serialized assemblies replaced during the repair of out-of-warranty equipment are warranted for a period of 12 months.
- Travel charges for Branson service personnel will be waived on service calls performed within 30 days of invoice date.
- Non-serialized parts replaced during the repair of out-of-warranty equipment are warranted for 3 months.
- Trade in allowance: Branson out-of-warranty serialized components are entitled to a 25% trade in allowance regardless of age or condition, however, converters must be less than 5 years old to qualify for the trade in.

If you have any questions concerning the warranty coverage (including coverage outside of North America), please contact your Branson representative or Branson Customer Support.

1.4 How to Contact Branson

Branson is here to help you. We appreciate your business and are interested in helping you successfully use our products. To contact Branson for help, use the following telephone numbers, or contact the field office nearest you.

- **Danbury Main Number (all Departments):** (203) 796-0400 (Eastern Time Zone)
- **Parts Store (direct number):** (877) 330-0406 (Central Time Zone)
- **Repair department:** (877)-330-0405 (Central Time Zone)
- **For emergency after-hours service (5pm-8am Est):** (203) 796-0500 (US phone numbers only).

Tell the operator which product you have and which person or department you need (see Section [1.5.3 Departments to Contact](#)). If you are calling after hours, please leave a voice message with your name and return telephone number.

1.4.1 Before Calling Branson for Assistance

This manual provides information for troubleshooting and resolving problems that could occur with the equipment (see Chapter 7). If you still require assistance, Branson Product Support is here to help you. To help identify the problem, use the following questionnaire which lists the common questions you will be asked when you contact the Product Support department.

Before calling, determine the following information:

1. Your company name and location.
2. Your return telephone number.
3. Have your manual with you. If troubleshooting a problem, refer to Chapter 7.
4. Know your equipment model and serial numbers (found on a gray data label on the units). Information about the Horn (part number, gain, etc.) or other tooling may be etched into the tooling. Software- or firmware-based systems may provide a BOS or software version number, which may be required.
5. What tooling (horn) and booster are being used?
6. What are the setup parameters and mode?
7. Is your equipment in an automated system? If so, what is supplying the “start” signal?
8. Describe the problem; provide as much detail as possible. For example, is the problem intermittent? How often does it occur? How long before it occurs if you are just powering up? If an error is occurring, which error (give error number or name)?
9. List the steps you have already taken.
10. What is your application, including the materials being processed?
11. Have a list of service or spare parts you have on hand (tips, horns, etc.)
12. Notes: _____

1.5 Returning Equipment for Repair

Before sending equipment for repair, provide as much information with the equipment to help determine the problem with the system. Fill in any details below or on a separate sheet.

Describe the problem; provide as much detail as possible. For example, is this a new problem? Is the problem intermittent? How often does it occur? How long before it occurs if you are just powering up?



NOTE

To return equipment to Branson, you must first obtain an **RGA number** from a Branson representative, or the shipment may be delayed or refused

If you are returning equipment to Branson for repair, you must first call the Repair department to obtain a Returned Goods Authorization (RGA) number. (If you request it, the repair department will fax a Returned Goods Authorization form to fill out and return with your equipment.)

Branson Repair Department, C/O Zuniga Logistics, LTD

12013 Sara Road, Killam Industrial Park

Laredo, Texas 78045 U.S.A.

direct telephone number: (877) 330-0405

fax number: (877) 330-0404

- Provide as much information as possible that will help identify the need for repair.
- Carefully pack the equipment in original packing cartons.
- Clearly label all shipping cartons with the RGA number on the outside of cartons as well as on your packing slip, along with the reason for return.
- Return general repairs by any convenient method. Send priority repairs by air freight.
- You must prepay the transportation charges FOB Laredo, Texas, U.S.A.

1.5.1 Get an RGA Number

RGA# _____

If you are returning equipment to Branson, please call the Repair Department to obtain a Returned Goods Authorization (RGA) number. (At your request, the Repair Department will fax an RGA form to fill out and return with the equipment.)

1.5.2 Record information about the Problem

Before sending equipment for repair, record the following information and send a copy of it with the equipment. This will greatly increase Branson's ability to address the problem.

1. Describe the problem; provide as much detail as possible.
For example, is the problem intermittent? How often does it occur? How long before it occurs after powering up?

2. Is your equipment in an automated system? NO / YES
3. If the problem is with an external signal, which signal? _____
If known, include plug/pin # (e.g., P29, pin #3) for that signal: _____
4. What are the Weld Parameters?

5. What is your application? (Type of weld, plastic material, etc.)
6. Name and phone number of the person most familiar with the problem:

7. Contact the Branson office prior to shipping the equipment.
8. For equipment not covered by warranty, to avoid delay, include a Purchase Order.

Send a copy of this page with the equipment being returned for repair.

1.5.3 Departments to Contact

Call your local Branson Representative, or contact Branson by calling, and asking for the appropriate department as indicated in [Table 1.2: Branson Contacts](#) below.

Table 1.2 *Branson Contacts*

What you need help with or information about . . .	Who to Call	At this Phone Number
Information about new welding systems or components	Your local Branson Rep or Branson Customer Service	203-796-0400 Ext 384
Application and Setup questions on the welding system	Welding Applications Lab	203-796-0400 Ext 368
Application assistance on the Horns and Tooling	ATG Lab	203-796-0400 Ext 495
Technical questions about the welding system	Welding Product Support	203-796-0400 Ext 355
Technical questions about Horns and Tooling	ATG Lab	203-796-0400 Ext 495
Ordering new parts	Parts Store	877-330-0406
RGA's, Request for Repair, Status of a Repair	Welding Repair Department	877-330-0405
System Automation/Hookup Information	Product Support	203-796-0400 Ext 355

My Local Branson Representative's name is:

I can reach this representative at:

1.5.4 Pack and Ship the Equipment

1. Carefully pack the system in original packing material to avoid shipping damage. Plainly show the RGA number on the outside of cartons as well as inside the carton along with the reason for return. Make a list of all components packed in the box. KEEP YOUR MANUAL.
2. Return general repairs by any convenient method. Send priority repairs by air freight. Prepay the transportation charges FOB the repair site.



NOTE

Items that are sent Freight Collect will be refused.

1.6 Obtaining Replacement Parts

You can reach Branson Parts Store at the following telephone numbers:

Branson Part Store

direct telephone number: 877-330-0406

fax number: 877-330-0404

Many parts can be shipped the same day if ordered before 2:30 p.m., Eastern time.

A parts list is found in Chapter 7 of this manual, listing descriptions and EDP part numbers. If you need replacement parts, coordinate the following with your purchasing agent:

- Purchase order number
- 'Ship to' information
- 'Bill to' information
- Shipping instructions (air freight, truck, etc.)
- Any special instructions (for example, "Hold at the airport and call"). Be sure to give a name and phone number
- Contact name information

Chapter 2: Introduction to the 2000X ao Actuator

2.1	Models Covered	2-1
2.1.1	Power Supply Manual Set	2-2
2.1.2	Actuator Manual Set	2-3
2.2	Overview of this Model	2-3
2.3	Features of the System	2-4
2.4	Controls and Indicators	2-7
2.5	Welding Systems	2-8
2.6	Glossary of Terms	2-10

The 2000X ao Actuator provides motion, force, power (from the power supply), and cooling air to the ultrasonic stack assembly. The 2000X ao Actuator is designed to work with a Branson 2000d Power Supply.

2.1 Models Covered

This manual covers the Branson 2000X ao Actuator. The 2000X ao Actuator may be found in one of several configurations:

- An Actuator on a Column Support, Column and Ergonomic Base, also called a Stand on Base (as seen on the following page)
- An Actuator on a Column Support, Column and Mounting Hub, sometimes called a Stand on Hub
- An Actuator alone (not installed on a Column Support, and so on.). These are often used in custom or automated systems that provide a means of positioning the Actuator.

This manual covers these configurations. A 2000X-series actuator requires a 2000X-series power supply to function, and that is covered in separate manuals and user documents.

Figure 2-1 shows a Branson 2000X ao Actuator mounted on a column support which, in turn is mounted on a column, and is supported by the ergonomic base.

i NOTE

Pneumatics are sold separately and referred to as rp as covered by this manual.

Figure 2.1 Right Side View of the 2000X ao Actuator

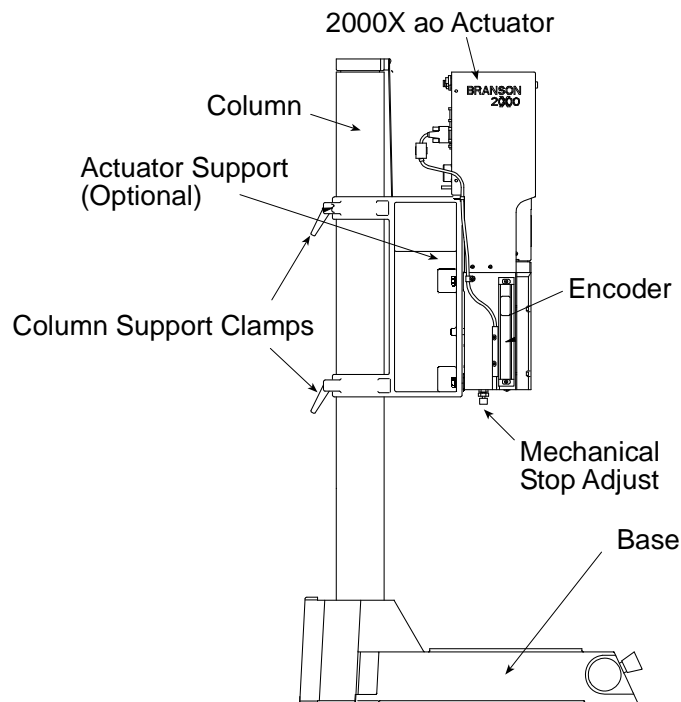

2.1.1 Power Supply Manual Set

The following documentation is available for the Branson 2000X-series Power Supplies that are compatible with the 2000X ao Actuator:

- 2000X ea Power Supply Instruction Manual (EDP 100-214-278)
- 2000-Series Installation Guide (EDP 100-214-226)
- 2000X ea Quick Start User's Guide (EDP 100-214-281)

2.1.2 Actuator Manual Set

The following documentation is available for the Branson 2000X [aeao](#) Actuator:

- Installation Guide (EDP 100-214-226)
- [ao](#) Actuator Instruction Manual (EDP 100-214-)

2.2 Overview of this Model

The 2000X ao Actuator is a compact, rigid unit designed for use in manual, semi-automated, and automated ultrasonic welding systems. The Actuator can be mounted directly on an I-beam (or similar machine frame), or it can be mounted on a column and base with start switches and used in a manual or benchtop system. The Actuator is designed to be operated in an upright position, but is capable of running horizontally or inverted. If you are mounting your equipment in an inverted position, contact Branson for further recommendations. (See *Section 1.5.3, Departments to Contact*, on page 1-13.)

The 2000X ao Actuator requires a 2000X ea Series Power Supply for power and control of the Actuator's operation and to provide ultrasonic power to the Converter in the Actuator.

The 2000X ao Actuator is designed with remotely-mountable pneumatic controls. Operation of the 2000X ao is controlled by inputs to the 2000X ea Power Supply. Having remote pneumatic controls allows easier user access to the Actuator settings, often important in automated systems.

The pneumatics covered in this manual refer to the remote box package sold by Branson. Some customers may require custom controls.

The Carriage and Slide System

The 2000X ao Actuator's carriage is driven by a double-acting air cylinder. It is mounted on a linear ball-bearing slide. The slide system is based on eight sets of preloaded, **permanently lubricated** bearings and provides consistent, precise alignment of the horn, smooth linear motion, and long-term reliability.

The Pneumatic System

The pneumatic controls on the 2000X ao are contained in the 2000Xrp Remote Pneumatics box, which is connected to the Actuator with three (3) 1/4-inch-OD poly tubing lines. The 2000X ao Actuator's carriage and sheet-metal enclosure contains the air cylinder, which receives air pressure and control from the 2000X rp. The air pressure regulator, solenoid valves, and air pressure gauge are found in the remote box. Filtered factory air is connected to the 2000X ao.

The horn's rate of descent is adjusted by the Downspeed control on the Remote Pneumatics Box. The rate of return is fixed. For information on setting the Downspeed control, see *Section 2.4: Controls and Indicators*.

Dynamic Triggering and Follow-Through

Many welding applications require force to be built up on the part before ultrasonic energy is activated. To achieve this, the Actuator contains a dynamic triggering mechanism located between the air cylinder and the converter, which initiates (triggers) ultrasonics after a preset force is applied to the part. Dynamic follow-through maintains a consistent force on the part during the weld collapse. This system helps provide uniform weld quality.

The dynamic triggering and follow-through process operates as follows: upon activation of the operating cycle, the solenoid valve delivers system air to the upper portion of the cylinder, and proportional air to lower portion of the cylinder, causing the horn to advance and contact the workpiece. As the pressure increases, the cylinder compresses springs, forcing a cam to break the optical beam of the trigger switch. When the trigger switch closes, a signal is sent to the Power Supply, which then starts the weld cycle. At this time, the actuator locks into a cycle, timing begins, and the palm buttons can be released. As melting of the plastic occurs, spring reaction the follow through maintains consistent force on the part, ensuring smooth, efficient transmission of ultrasonic energy into the part.

2.3 Features of the System

Listed below are many features of the Branson 2000X-series ultrasonic welding system included in a ao2000X ao Actuator and 2000X Series Power Supply.

- **19" Rack Mount Enclosure:** Compatible with industry standard 19" rack enclosure systems.
- **Vacuum Fluorescent Display:** For good visibility in any factory lighting situation.
- **Membrane Keyboard:** For high reliability and immunity from factory dust and oils.
- **Digital Tuning:** An advanced means to tune the Power Supply for applications and horns at the extremes of the Power Supply capture range.
- **Autotuning:** Branson Power Supply tuning ensures that the system is running at peak efficiency.
- **Weld Modes:** This welder offers multiple weld modes so that you can choose the best mode of control that meets your specific application need: Time, Energy, Peak Power, and Ground Detect.
- **Print on Alarm:** You can request any printable items whenever an alarm occurs. This will give you the information you need to determine how your setup or limits can be changed.
- **Print on Sample:** You can request any printable items based on a sampling rate. This facilitates auditing your process and lot control.

- **Print Now:** At any time, you can request any printable items for the last cycle completed.
- **Amplitude Stepping:** A patented Branson process, controlled by the Power Supply. At a specified time, energy, peak power, distance, or by external signal you can change the amplitude during the weld to control the flow of plastic. This feature helps ensure part consistency, higher strength parts and control of flash.
- **Digital Horn Test Diagnostics:** In Test mode of the Power Supply, you can view the Horn Test results in digital form, using digital readouts and bar graphs on the Power Supply to give you the best picture of the stack's operation.
- **Digital Readout of Distance During Setup/Horn Down:** During Horn Down, absolute distance is displayed digitally so that you can determine the correct values for your process limits and cutoffs.
- **Auto-Scaling of Graphs in Time Mode:** When you request a graphic printout in Time Mode, the Power Supply automatically scales the time axis of the graph to give you the most meaningful graph possible.
- **User-Selectable Graph Scales:** In any mode, you can select the scale of the time axis so that you can zoom in on a critical portion of the data.
- **Host Communications through RS232 Interface:** The 2000a Power Supply supports communications to a host computer system by RS232 connection. You can use this to download setups, modify setups, or read weld process data for off-line analysis or storage.
- **Graphic Printing of Power, Velocity, Amplitude, and Frequency:** The 2000a Power Supply supports graphic printouts of these items. These graphs include markers to show critical points in the weld. Use these graphs to optimize your weld process or diagnose application problems.
- **Pretrigger:** This feature allows you to set the system weld controls to turn the ultrasonics on *before* contact with the part.
- **Afterburst:** This feature allows you to set the system weld controls to turn the ultrasonics on *after* the weld and hold steps to release parts from the horn.
- **Control Limits:** With some power supply models, these secondary controls are used in conjunction with the main parameters of the weld parameters. These user-programmed limits provide for adaptive control of the weld process.
- **Cycle Aborts:** These are user-programmed conditions at which the process will be terminated. These can be used as safety limits to save wear and tear on the system and your tooling.
- **Digital Amplitude Setting:** This feature allows you to set the exact amplitude necessary for your application, affording increased repeatability over analog systems.
- **Password Protection:** This feature allows you to secure your setup from unauthorized changes. You can select your own password up to six characters.
- **Adjust While Running:** The 2000a Power Supply allows you to modify the weld parameters while the welder is running. This can be of benefit in automated systems where you do not want to shut down the entire line to make a minor modification.

- **Background Printing:** This feature allows you to print the results of the previous cycle while performing a new cycle.
- **Suspect Limits:** A class of user-definable alarms that alert you if a part falls into a range that you have determined should be inspected.
- **Reject Limits:** A class of user-definable alarms that alert you if a part falls into a range that you classified as reject parts.
- **Process Alarm Display Showing Actual and Set Values:** When an alarm condition has occurred, you can view the value for the last weld and the suspect and reject settings you programmed into the controls.
- **Post Weld Seek:** This system feature provides a short burst of energy at the end of the weld Hold and Afterburst steps to automatically retune the power supply, if required.
- **Frequency Offset:** This process feature allows a user to set a frequency value, for certain specific applications, where the force imparted on the fixture or anvil causes a frequency shift in the Stack's operation. You should only use this feature when advised to do so by Branson.
- **1 Millisecond Control and Sampling Rate:** This feature provides sampling and control of the weld process 1000 times each second.
- **Parallel Port:** The Power Supply allows the connection of a dot-matrix Printer to print weld results data.
- **Cycle Time and Date Stamp:** The 2000a Power Supply provides each cycle with a time and date stamp for production and quality control purposes.
- **English (USCS)/Metric Units:** This feature allows the welder to be set up in the local units in use.
- **Startup Diagnostics:** At power supply startup, the controls test the major system components, including the Actuator and its controls.
- **Weld Parameter Entry through Digital Keypad:** User Setup is direct and easy, by selecting the menu parameter by name and using the keypad to enter the precise value. The controls also support entry by incrementing existing values.
- **System Information Screen:** This is a screen that will give you information about your welding system (e.g., cylinder size, stroke length, number of cycles). Refer to this screen when contacting Branson for service and support.
- **Feature Advanced or Normal:** To simplify the menus the 2000a Power Supply can be set to Normal. When it is set to Normal, many of the advanced and sophisticated features are unavailable.
- **Sequencing of Presets:** In automated applications or where more than one weld is to be performed on a part, you can establish a sequence of presets that can be run. This eliminates the need to add outside controls for the selection of presets.
- **Ramp Starting:** The starting of the 2000X-series apower supply and horn is done at the optimum rate to reduce electrical and mechanical stress on the system. This also helps make some tough-to-start applications possible.
- **True Wattmeter:** The controls on the power supply include a true wattmeter for accurate measurement of power and energy.
- **Downspeed:** Controls the rate of descent and force build-up on the part.

2.4 Controls and Indicators

The Actuator Controls for the 2000X ao Actuator are found in two locations: on the Actuator or on the Remote Pneumatics Box. The 2000X rp is a separate component of a 2000X ao. System controls and Actuator power are provided by the 2000X-series Power Supply.

- **Stroke Indicator** Provides a quick method of determining relative carriage travel during an operating cycle. A scale is provided to indicate relative distance.



NOTE

The mechanical stop is not intended for welding by distance. The mechanical stop is not intended for welding by distance.

The front panel controls on the 2000X ao Actuator are listed below.

- **Pressure Indicator:** Indicates that the actuator is receiving pressurized air.
- **Power Light:** Indicates that the Actuator is connected to the Power Supply and that the Power Supply's main power is on.
- **Carriage Door:** Provides access to the converter-booster-horn stack; secured by four M5 hex screws. Use a T-handle wrench to tighten the hex screws.
- **Mechanical Stop:** Limits the stroke length to prevent the horn from contacting the fixture when no workpiece is in place; adjustment is approximately 0.04 in. (1 mm) per rotation; a locking ring keeps the setting from vibrating loose. Turning the knob clockwise increases the stroke length.



CAUTION

Turning the mechanical stop too far can cause it to come apart.

Controls on the 2000X rp Remote Pneumatics Box are listed below.

- **Pressure Regulator:** Adjust the amount of air pressure applied to the cylinder; range of 5-100 psig (35-700 kPa). Pull to set; push to lock.
- **Downspeed Control:** Downspeed knob controls the rate of descent and force buildup on the part to be welded.
- **Pilot Light:** Indicates that the actuator is connected to the power supply, that the 2000X rp remote box is electrically connected to the 2000ao actuator, and that the power supply's main power is on.
- **Pressure Gauge:** Indicates the amount of air pressure applied to the cylinder; range of 5-100psig (35-700 kPa). Pull to set; push to lock.

2.5 Welding Systems

Ultrasonic Plastics Welding

Thermoplastic parts are welded ultrasonically by applying high-frequency vibrations to the parts being assembled. The vibrations, through surface and intermolecular friction, produce a sharp rise in temperature at the welding interface.

When the temperature is high enough to melt the plastic, there is a flow of material between the parts. When the vibrations stop, the material solidifies under pressure and a weld results.

The Plastics Welding System

The welding system consists of a power supply, an actuator, and a converter-booster-horn stack. The system can perform a variety of ultrasonic welding operations, including: inserting, staking, spot welding, swaging, degating, and continuous operations. It is designed for use in automated, semi-automated, and/or manual production systems.

Power Supply

The 2000X Series digital Power Supply converts conventional 50/60 Hz line current to high frequency electrical energy. It also contains all the electronic controls and can be located remotely from the Actuator. This allows the operator to adjust or reprogram the welding cycle remotely from the Actuator and related welding, tooling, and parts-handling systems.

The 2000X Series Power Supply also contains a DC power supply for electrical power to operate the electrical components and control circuits in the power supply, and on the Actuator.

Converter

The converter is mounted in the actuator as part of the ultrasonic stack. The ultrasonic electrical energy from the power supply is applied to the converter (sometimes called the transducer). This transforms the high frequency electrical oscillations into mechanical vibrations at the same frequency as the electrical oscillations. The heart of the converter are piezoelectric ceramic elements. When subjected to an alternating voltage, these elements alternately expand and contract, resulting in better than 90% conversion of electrical to mechanical energy.

Booster

Success in ultrasonic assembly depends on the right amplitude of movement at the horn face. Amplitude is a function of horn shape, which is largely determined by the size and form of the parts to be assembled. The booster can be used as a mechanical transformer to increase or decrease the amplitude of vibrations applied to the parts through the horn.

The booster is a resonant half-wave section of aluminum or titanium. It is mounted between the converter and the horn, as part of the ultrasonic stack. It also provides a clamping point for rigid stack mounting.

Boosters are designed to resonate at the same frequency as the converter with which they are used. Boosters are usually mounted at a nodal (minimum vibration) point of axial motion. This minimizes the loss of energy and prevents vibration from being transmitted into the actuator.

Horn

The horn is selected or designed for a specific application. Each horn is tuned typically as a half-wave section that applies the necessary force and vibration uniformly to the parts to be assembled. It transfers ultrasonic vibrations from the converter to the workpiece. The horn is mounted to the booster as part of the ultrasonic stack.

Depending on their profile, horns are referred to as stepped, conical, exponential, bar, or catenoidal. The shape of the horn determines the amplitude at the face of the horn. Depending on the application, horns can be made from titanium alloys, aluminum, or steel. Titanium alloys are the best materials for horn fabrication due to their high level of strength and low loss. Aluminum horns are usually chrome- or nickel-plated or hard-coated to reduce wear. Steel horns are for low amplitude requiring hardness, such as ultrasonic insertion applications.

Dynamic Trigger Mechanism and Dynamic Follow Through

The Dynamic Trigger Mechanism assembly ensures that pressure is applied to the part prior to the application of ultrasonic energy. This adjustable, pressure-activated device is located between the air cylinder and the converter.

To maintain horn-to-part contact and force as the joint collapses, springs provide dynamic follow-through. As the plastic melts, the springs extend to ensure smooth transmission of ultrasonic energy into the part.

2.6 Glossary of Terms

The following terminology may be encountered when using or operating a 2000X-series ultrasonic welding system. Some of these terms may not be available in all Controls (Power Supply model) configurations:

AB Amplitude: The amplitude at the horn face during the afterburst step.

AB Delay: Time delay between the end of the hold and the start of the afterburst.

AB Time: The duration of the afterburst.

Abort Current Printing: Terminates the current printing request.

Absolute Cutoff: Ends the ultrasonic portion of the cycle when the set absolute distance is reached.

Absolute Distance: The distance the horn has travelled from home (ULS deactivation).

Absolute Mode: A mode of operation in which the ultrasonic portion of the cycle is terminated when a user-specified distance from home has been reached.

Absolute Position: The position of the actuator after clearing the Upper Limit Switch.

Actual: A reported value that occurred during the weld cycle. The converse is the set parameter that was requested during the setup.

Adjust While Running: Allows modifications to weld parameters while the welder is running.

Afterburst: Ultrasonic energy applied after the hold step. Used to break away sticking parts from the tooling.

Alarm Beeper: An audible signal that sounds when a general alarm has occurred.

Amplitude: The peak-to-peak movement at the horn face. Always expressed as a percentage of the maximum.

Amp A: The amplitude applied to the part from the start of the weld to the step change.

Amp B: The amplitude applied to the part from the step change to the end of the weld.

Amplitude Graph: A graph of amplitude percentage plotted against time.

Amplitude Step: A change in amplitude during the ultrasonic portion of the cycle.

Amp Control: The ability to set amplitude digitally or by an external control.

Automatic: A pretrigger condition indicating that pretrigger engages when the actuator leaves the upper limit switch.

Baud Rate: The rate of data transmission over the serial communication port.

Beep: An audible signal produced by the Branson control board. Used to alert the operator to an unexpected condition.

Calibrate Actuator: The menus that guide you through the actuator calibration to calibrate distance and force that must compensate for horn mass and return spring force.

Calibrate Power: The ability to calibrate the reported power against an outside standard.

Calibrate Sensors: The ability to calibrate the reported pressure sensor and force against an outside standard.

Calibrate Standards: The menu title for accessing the calibration and verification of pressure, force, power, and energy.

Cold Start: A condition that restores a setup to its default values.

Collapse Cutoff: Ends the ultrasonic portion of the cycle when the set parameter is reached.

Collapse Distance: The distance the horn has travelled from the trigger point of ultrasonics.

Collapse Mode: A mode in which the ultrasonics portion of the cycle is terminated when a user-specified distance from the trigger point has been reached.

Control Limits: Additional parameters that determine the end of the ultrasonic portion of the cycle and the move to the hold state.

Converter: The device that converts electrical energy into mechanical vibrations at a high frequency (an ultrasonic rate). The Converter is a central component of the welding system and is mounted in the Actuator.

Counters: A record of the number of cycles run by category, for example, alarms, good parts, and so on, recorded in the Controls.

Cycle Aborts: Settings that end the cycle immediately.

Digital Filter: A smoothing technique used to provide more meaningful data.

Down Speed: The user-definable speed of descent (percentage of maximum speed) during the down stroke of the Actuator.

Energy Mode: A mode of operation in which ultrasonics are terminated at a user-specified energy value.

External Amplitude Control: Enables you to access real-time amplitude control directly.

External Frequency Control: Enables you to access real-time frequency control directly.

Force A: The force applied to the part from the start of the weld to the step change.

Force B: The force applied to the part from the step change to the end of the weld.

Force Step: A change of force during the cycle.

Form Feed: When using a printer with the 2000Xd Power Supply to capture weld data, you can insert a form feed after print setup, print graph, or after reaching the number of lines per page.

Frequency: The operating frequency of the ultrasonic stack. The frequency stored is measured at the end of the ultrasonic portion of the cycle (when ultrasonics are terminated).

Freq End: The frequency at the end of the ultrasonic portion of the welding cycle (when ultrasonics are terminated).

F Actual: The actual running frequency of the acoustic system.

F Memory: The frequency stored in the Power Supply memory.

Frequency Offset: An offset factor applied to the ultrasonic frequency stored in the Power Supply.

General Alarm: An alarm that occurs due to system fault and/or tripping a limit.

Ground Det. Cutoff: Ground Detect Cutoff. Immediately terminates the weld process, including the hold step, when a ground detect has occurred.

Gnd Det. Mode: Ground Detect Mode, available in all models of 2000X power supplies. In this mode of operation, ultrasonics are terminated after detection of a ground condition between the horn and fixture or anvil.

Hand Held System: Operation using a manual trigger. Sometimes used in automated systems when the solenoid valve will not be activated and only one start switch is needed to initiate a cycle.

Hold Force: The force on the part during the hold portion of the cycle.

Hold Time: The duration of the hold step.

Horn Down: A mode in which ultrasonics are locked out and the user can advance the Actuator for setup and alignment.

Linear Encoder: Provides carriage (horn) distance measurement during the Actuator cycle.

Lines per Page: When using an optional Printer, the number of welds per printed page.

Load Cell: Provides force measurement for accurate ultrasonic triggering and graphing of force.

Main Menu: The list of categories of features available in the software, as displayed on the front panel of the Power Supply. Accessible by using a power supply front-panel button.

Max Energy: Maximum Energy. The maximum user-specified energy that produces a part without an alarm.

Min Energy: Minimum Energy. The minimum user-specified energy that produces a part without an alarm.

Minus Limit: The user-defined lower limit, or lower extreme of an acceptable range for a given parameter. See Control Limits in the Power Supply manual.

Missing Part: Returns the actuator to the home position and displays an alarm indicating that the cycle was aborted because no part was present.

Parameter Range: Valid range of parameters accepted for a particular setup.

Parameter Step: Ability to dynamically change either amplitude or force during the weld cycle.

Password: A user-defined access code for the secure areas of the Power Supply's user controls.

Password Protection: Enables lock-out of the Power Supply's weld parameter modification by using a user-defined password.

Peak Power Cutoff: A power value that terminates the ultrasonics when peak power is not the primary control mode.

Pk Pwr Mode: Peak Power Mode. A mode of operation in which ultrasonics are terminated at a user-specified power value in percentage of maximum.

Plus Limit: The user-defined upper limit. See Control Limits, Suspect, Reject and Missing Part Limits in the Power Supply manual.

Post Weld Seek: Used to determine the operating frequency of the Stack, after the Hold and/or Afterburst portion of the weld cycle. Ultrasonics are run at a low level (5%) amplitude during this step, and the frequency is stored to memory.

Power Graph: A printed graph of power in percentage of maximum plotted against time.

Preset: A method of saving the power supply's user-set parameters to memory, for a given Setup. The Power Supply model may allow multiple presets for easy recall of a Setup's parameters, for a given part, process or operation. Presets can be labeled by the user or the system.

Preset Name: The ability to name a preset in customer-defined terms. Not available in the 2000Xt Power Supply.

Pretrigger: The setting that causes ultrasonics to start before contact with the part (or, before the set Trigger Force has been met).

Pretrig Amp: Pretrigger Amplitude. The amplitude at the horn face during pretrigger.

Pretrig At: Pretrigger at (a given distance). The distance at which pretrigger is turned on.

Print on Alarm: Allows the user to set up printing automatically when an alarm occurs.

Print on Sample: Allows the user to set up printing automatically based on the number of cycles performed.

Ready Position: State in which the welder is retracted to the home position and ready to receive the start signal, ready to operate.

Recall Preset: Allows a user to activate a preset from memory for purposes of operation or modification.

Reject Limits: User-definable limits at which the violating cycle is identified as having produced a bad part.

Required: State used with limits indicating that a reset will be required when the limit is exceeded. The reset is accomplished by using the reset key on the front of the Power Supply.

Reset Required: State used with limits indicating that a reset will be required when the limit is exceeded. The reset is accomplished by using the reset key on the front of the Power Supply.

Run Dry Cycle: A cycle without ultrasonics. Used for diagnostic purposes.

Run Screen: The screen showing weld status, alarms, weld count, and process information. Available using a front-panel button on the Power Supply.

Save Preset: Stores a programmed set of weld parameters as a Preset.

Scrub Time: In Ground Detect mode, the amount of time after detection of a ground condition before the termination of ultrasonics, and end of the cycle.

Seek: The activation of ultrasonics at a low-level (5%) amplitude, for the purpose of finding the resonant frequency of the Stack.

Sequence: Allows the sequencing of presets within the welder so that multiple weld points can be performed with one welding Power Supply and Actuator.

Serial Port: A RS232 port provided to you for external data communications.

Step @ Energy: User-definable point at which AmpA or ForceA is changed to AmpB or ForceB.

Step @ Ext Sig: Allows you to shift either force or amplitude based upon an external signal.

Step @ Force: User-definable point at which AmpA is changed to AmpB.

Step @ Power: User-definable point at which AmpA or ForceA is changed to AmpB or ForceB.

Step @ Time: User-definable point at which AmpA or ForceA is changed to AmpB or ForceB.

Suspect Limits: User-definable limits at which the resultant weld in a welding cycle is identified as potentially bad (suspect).

Test Scale: The magnification of the power bar on the front panel of the Power Supply, useful for lower-power applications that want a more accurate (but smaller) scale.

Time Mode: Terminates the ultrasonics at a user-specified time.

Timeout: A time at which the ultrasonic energy terminates if the main control parameter has not been reached.

Trigger Beeper: An audible signal sounded when the trigger force has been met, and the trigger switch is made.

Trig Delay: Trigger Delay. A user-programmable time delay between engagement of the trigger switch and start of ultrasonics and ramping of force to the weld force.

UPS: Universal Power Supply.

User-defined Limits: for process resultants, where - is the user-defined lower limit, and + is the user defined upper limit:

-/+ S/R Energy: The energy reached during the weld.

-/+ S/R Freq: The peak frequency reached during a weld.

-/+ Max Force: The peak force reached during the weld.

-/+ S/R Power: The peak power as a percentage of the maximum reached during the weld.

-/+ S/R Abs D: The absolute distance reached during the weld from the Upper Limit Switch.

-/+ S/R Col D: The collapse distance reached from trigger to end of weld.

-/+ S/R Trg D: The distance at which the trigger occurred.

-/+ S/R Time: The weld time reached during the weld.

Weld Count: Count of acceptable weld cycles.

Weld Energy: The energy specified to be applied to the part during the weld cycle.

Weld History: The last 50 weld summary data lines are saved.

Weld Scale: The power bar LED scale during weld.

Weld State: A screen message showing the current state of the welder during or before the process. The list of messages are shown in the Run Screen section.

Weld Results: A one-line summary of information concerning the last weld cycle.

Weld Time: The time for which ultrasonics are on.

Chapter 3: Delivery and Handling

3.1 Shipping and Handling	3-1
3.1.1 Environmental Specifications	3-1
3.2 Receiving	3-2
3.3 Unpacking	3-3
3.3.1 Actuator Assemblies	3-3
3.4 Returning Equipment	3-3

3.1 Shipping and Handling

3.1.1 Environmental Specifications

The ao Actuator is a system of cast and electro-pneumatic components that move the ultrasonic tooling in the ultrasonic welding system and control aspects of the weld process. Many of its components can be harmed if the unit is dropped, shipped under improper conditions, or otherwise mishandled. The following environmental guidelines should be respected in the shipping of the ao Actuator unit.

Table 3.1 *Environmental Specifications*

Environmental Condition	Acceptable Range
Humidity	Maximum non-condensing
Storage / Shipping Temperature	-25°C/-13°F to +55°C/+131°F (+70°C/+158°F for 24 hours)
Shock / Vibration (transit)	60 g shock / 0.5 g and (3-100 Hz) vibration per ASTM 3332-88 and 3580-90

3.2 Receiving

Branson Actuator units are carefully checked and packed before dispatch. It is recommended, however, that you follow the procedure below upon receiving your Actuator.

Inspect the Actuator when it is delivered:

Step:	Action:
1	Check the equipment immediately after delivery to ensure that they have not been damaged during transport.
2	Verify that all parts are complete according to the delivery note.
3	Determine if any component has become loose during shipping and, if necessary, tighten screws.



NOTE

If the goods delivered have been damaged during shipping, please contact the forwarding agent immediately. Retain packing material (for possible inspection or for sending back the unit).



CAUTION

The Actuator and the Power Supply are heavy. Handling, unpacking, and installation may require the assistance of a colleague or the use of lifting platforms or hoists

3.3 Unpacking

3.3.1 Actuator Assemblies

Actuator assemblies are heavy and packed in a protective shipping container. The Booster, Converter, and Actuator Toolkit are often packed inside the shipping container.

Each Actuator is shipped as one of the three assemblies described below, with its own corresponding unpacking procedure. These assemblies vary in both the materials used for shipping and the actual components that you will receive when the Actuator is shipped. For complete Actuator unpacking and installation procedures, refer to *Chapter 4: Installation and Setup*.



NOTE

Remote pneumatics are always shipped in a separate box.

- **Stand (Actuator on Base):** A stand consisting of an Actuator on a Base is shipped on a wooden pallet with a cardboard box cover. (The packaging for this assembly is similar to that of an Actuator on Hub-Mounted Column.)
- **Stand (Actuator on Hub-Mounted Column):** A stand consisting of an Actuator on a hub-mounted column is shipped on a wooden pallet with a cardboard box cover. (The packaging for this assembly is similar to that of an Actuator on Base.)
- **Actuator (Alone):** An Actuator that does not use either type of stand is shipped in a rigid cardboard box using protective foam shells for support.

3.4 Returning Equipment

If you are returning equipment to Branson Ultrasonic Corporation, please call your Customer Service Representative to receive approval to return goods to Branson.

If you are returning equipment for repair refer to [Chapter 1: Safety and Support](#), Section [1.5: Returning Equipment for Repair](#), of this manual, for appropriate procedure.

Chapter 4: Installation and Setup

- 4.1 About Installation** - - - - - 4-2
- 4.2 Handling and Unpacking** - - - - - 4-2
 - 4.2.1 Unpack the Stand or Actuator - - - - - 4-3
 - 4.2.2 Stand (actuator on a base) - - - - - 4-3
 - 4.2.3 Stand (Actuator on a Hub) - - - - - 4-5
 - 4.2.4 Actuator (Alone) - - - - - 4-6
- 4.3 Take Inventory of Small Parts**- - - - - 4-7
 - 4.3.1 Cables - - - - - 4-8
- 4.4 Installation Requirements**- - - - - 4-9
 - 4.4.1 Location - - - - - 4-9
 - 4.4.2 Environmental Specifications - - - - - 4-9
 - 4.4.3 Electrical Input Power Ratings - - - - - 4-10
 - 4.4.4 Air Cylinder Consumption- - - - - 4-11
 - 4.4.5 Factory Air - - - - - 4-15
- 4.5 Installation Steps** - - - - - 4-16
 - 4.5.1 Mounting the Stand (Actuator on Base)- - - - - 4-16
 - 4.5.2 Mounting the Stand (Actuator on Hub-mounted column)- - 4-17
 - 4.5.3 Actuator (Alone) - - - - - 4-18
 - 4.5.4 Mount the Power Supply - - - - - 4-20
 - 4.5.5 Input Power (Main) - - - - - 4-21
 - 4.5.6 Output Power (RF Cable)- - - - - 4-21
 - 4.5.7 Interconnect between Power Supply and Actuator- - - - 4-21
 - 4.5.8 Start Switch Connection (Automation)- - - - - 4-23
 - 4.5.9 Serial (RS-232) Port Connector- - - - - 4-24
 - 4.5.10 Parallel Printer Connector - - - - - 4-24
 - 4.5.11 User I/O Interface - - - - - 4-24
 - 4.5.12 Input Power Plug - - - - - 4-27

4.5.13	User I/O DIP Switch (SW1) - - - - -	4-28
4.5.14	Module Options DIP Switch - - - - -	4-28
4.6	Guards and Safety Equipment- - - - - -	4-29
4.6.1	Emergency Stop Control - - - - -	4-29
4.7	Rack Mount Installation - - - - -	4-29
4.8	Assemble the Acoustic Stack - - - - -	4-31
4.8.1	For a 20kHz System - - - - -	4-31
4.8.2	For a 30kHz System - - - - -	4-32
4.8.3	For a 40kHz System - - - - -	4-32
4.8.4	Assembling the 20kHz Acoustic Stack - - - - -	4-33
4.8.5	Connecting Tip to Horn - - - - -	4-34
4.8.6	Installing the Stack in the Actuator- - - - -	4-35
4.9	Mounting the Fixture on the Branson Base - - - - -	4-37
4.10	Testing the Installation - - - - -	4-38
4.11	Still Need Help? - - - - -	4-39

4.1 About Installation

This chapter is intended to help the installer with the basic installation and setup of your new 2000ao Actuator.



CAUTION

The Actuator and related components are heavy. Handling, unpacking, and installation can require help or the use of lifting platforms or hoists.

International safety labels are found on the power supply and actuator. Those that are of importance during installation of the system are identified in the figures in this and other chapters of the manuals.

4.2 Handling and Unpacking

If there are any visible signs of damage to the shipping containers or the product, or you later discover hidden damage, NOTIFY YOUR CARRIER IMMEDIATELY. Save the packing material.

1. Unpack the 2000X-series components as soon as they arrive. Refer to the following procedures.
2. Verify you have all of the equipment ordered. Some components are packed inside other boxes.
3. Inspect the controls, indicators, and surfaces for signs of damage.
4. Save all packing material, including the pallets and wood spacer blocks. Evaluation systems will be returned using this packing material.

4.2.1 Unpack the Stand or Actuator

The stand (or actuator) is heavy and packed in a protective shipping container. The actuator toolkit is packed with the actuator. A booster, converter and other components may be packed inside the shipping container (depending on the equipment ordered).

- Stands are shipped on a wooden pallet with a cardboard box cover.
- Actuators (alone) are shipped in a rigid cardboard box using protective foam shells for support.

Depending on which one of the following options applies to you, unpack the Branson actuator assembly:

4.2.2 Stand (actuator on a base)



CAUTION

Heed the “This End Up” arrows and the “Open Top First” instructions. The packaging is designed to be removed from the assemblies from an upright orientation only.

Figure 4.1 Unpacking the Stand (Actuator on a Base); Right-side View of Stand

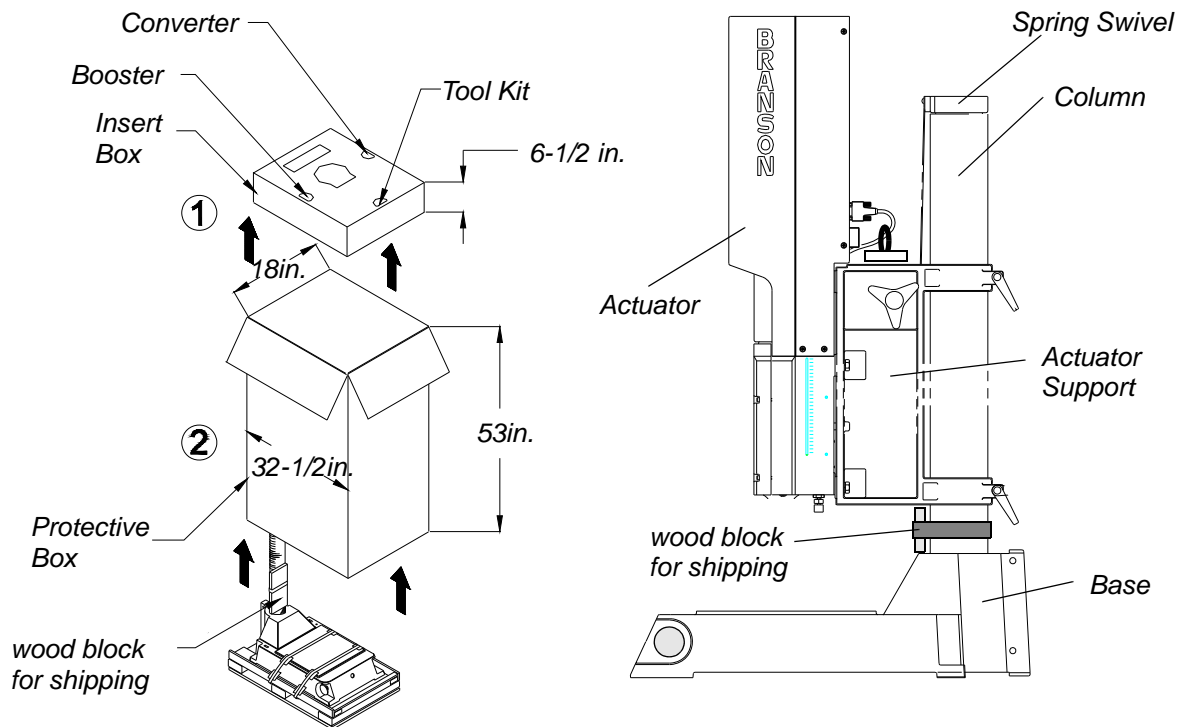

1. Move the shipping container close to the intended installation location, leave it on the floor.
2. Open the top of the box. Remove the insert from the top of the protective box, which may contain the booster, converter, and the toolkit.
3. Remove the staples at the bottom of the protective box. Lift the protective box off the pallet.



CAUTION

The column and column support are under spring tension from the counterbalance spring. Do NOT attempt to disassemble the column from the stand, but always keep the column support clamped together. When making height adjustments, carefully and slowly release the clamps to control the motion, and hold the stand to prevent sudden movements or injury.

4. Cut the two packing straps around the base and pallet. Pry off the two wooden shipping blocks (to the rear of the base) which prevent the base from sliding on the pallet.
5. The stand can now be moved into its desired location by sliding it off the pallet. Stands have a lifting hook for the use of overhead hoists to lift the assembly in place.
6. Remove the block of wood between the base and the column support by carefully loosening the two column clamps (allowing the actuator to rise slightly, but not allow sudden movements) and then cutting the shipping tape on the block of wood. **RETIGHTEN THE COLUMN CLAMPS.**
7. Unpack the toolkit from the insert box, and other parts (converter, booster, etc.) that may have shipped with the stand. Save the packing material.
8. Go to **Take Inventory of Small Parts**. See [Table 4.1 'Small Parts included \(=x\) with Power Supply and/or Actuator Assemblies' on page 4 - 7.](#)

4.2.3 Stand (Actuator on a Hub)

Figure 4.2 Unpacking the Stand (Actuator on a Hub); Hub Shown Separately

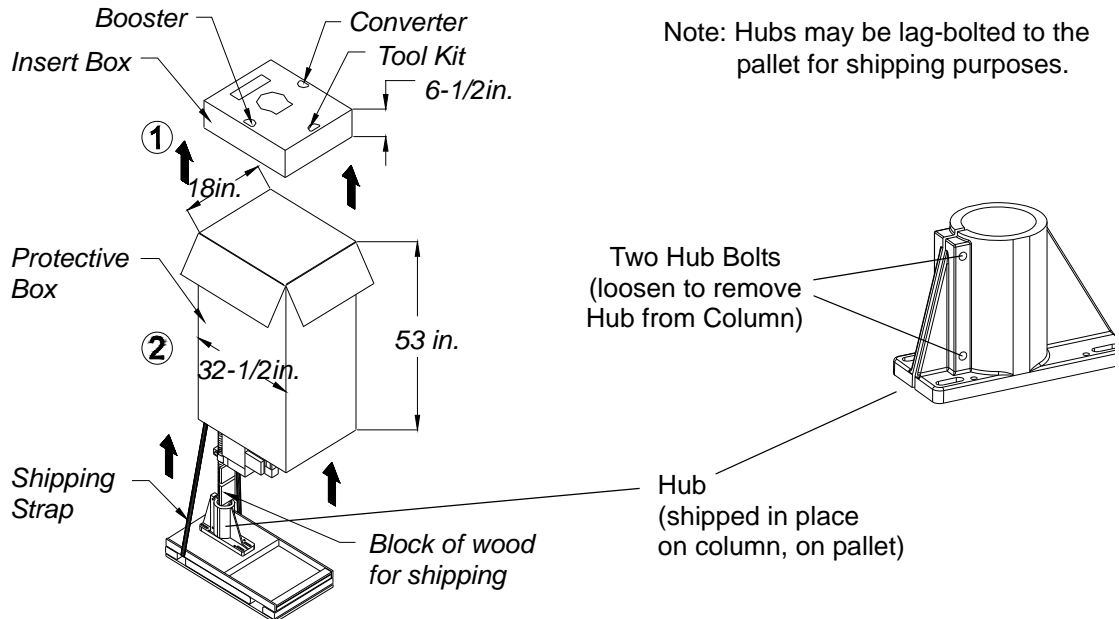

CAUTION

Heed the “This End Up” arrows and the “Open Top First” instructions. The packaging is designed to be removed from the assemblies from an upright orientation only.

1. Move the shipping container close to the intended installation location, leave it on the floor.
2. Cut the two vertical packing straps, and open the top of the box. Remove the insert from the top of the box, which can contain the booster, converter, and the toolkit. Set the insert box aside.
3. Remove the staples at the bottom of the protective box. Lift the protective box off the pallet. Flatten the box and lay it next to the pallet (you will lay the stand on it soon).



CAUTION

The unit may tend to tip over. Stabilize the stand using the lifting hook or an assistant.

4. Cut the packing strap securing the column support to the pallet.



CAUTION

The column and column support are under spring tension from the counterbalance spring. Do NOT attempt to disassemble the column from the stand, but always keep the column support clamped together. When making height adjustments, carefully and slowly release the clamps to control the motion, and hold the stand to prevent sudden movements or injury.

5. Remove the block(s) of wood between the base and the support by slowly loosening the two column clamps (allowing the stand to rise slightly) and then cutting the shipping tape on the block of wood. **RETIGHTEN THE COLUMN CLAMPS.**
6. Loosen the two hub bolts (for column clamping) on the hub.
7. Lift the actuator and column from the pallet. Carefully lay the stand on its right side (**NOT ON THE SIDE WITH THE LINEAR ENCODER**).
8. Remove the hub from the pallet and set it aside. Some hubs are bolted to the pallet from the top.
9. Unpack the converter, booster and toolkit from the insert box. Save the packing material, including the blocks of wood.
10. Go to **Take Inventory of Small Parts**. See [Table 4.1 'Small Parts included \(=x\) with Power Supply and/or Actuator Assemblies' on page 4 - 7.](#)

4.2.4 Actuator (Alone)

The actuator, if shipped alone, is assembled and ready to install.

Move the shipping container close to the intended installation location, leave it on the floor.

11. Open the top of the cardboard box, remove the insert from the top of the box and set it aside.
12. The toolkit, mounting bolts, and converter and/or booster are shipped with the actuator but in separate shipping box(es). Unpack the converter, booster, toolkit and bolts from their packages.
13. Save the packing material.



NOTE

The packaging may also include the converter and/or booster, if ordered.

Figure 4.3 Ultrasonic Converter (J-Type for Stand-Alone Use) and Booster

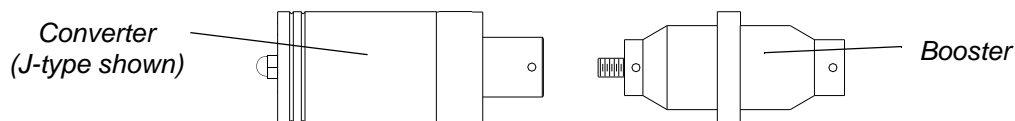

4.3 Take Inventory of Small Parts

Table 4.1 Small Parts included (=x) with Power Supply and/or Actuator Assemblies

Part or Kit	2000X Power Supply			Actuator		
	20kHz	30kHz	40kHz	Stand (Base)	Stand (Hub)	(alone)
T-Handle Wrench				x	x	x
Mylar Washer Kit	x	x				
Silicone Grease			x			
Actuator Mtg. Bolts						x
20kHz Spanners (2)	x					
30kHz Spanners (2)		x				
40kHz Spanners (2)			x			
40kHz Sleeve				ordered part	ordered part	ordered part
40kHz Sleeve Spanner				ships w/ Sleeve	ships w/ Sleeve	ships w/ Sleeve
Fixture Bolts and Washer				x		
M8 Allen wrench				x		
5/64 Allen wrench				x	x	x

4.3.1 Cables

Two cables connect the power supply and actuator: the actuator interface cable, and the RF cable. If the system is to be automated, you may also need a J911 start cable and a user I/O cable. Check your invoice for cable types and cable lengths.

Table 4.2 *List of Cables*

101-241-202	Remote Pneumatic (RP) Package Cable (J924), 8'
101-241-203	Actuator Interface, 8' (J925S)
101-241-204	Actuator Interface, 15'(J925S)
101-241-205	Actuator Interface, 25'(J925S)
101-241-206	Actuator Interface, 50'(J925S)
101-241-207	Alarm I/O, 8'(J957S)
101-241-208	Alarm I/O, 15'(J957S)
101-241-209	Alarm I/O, 25'(J957S)
101-241-258	Alarm I/O, 50'(J957S)
101-240-020	Start Cable (J911) 8' (req PLA)
101-240-015	Start Cable (J911) 15' (req PLA)
101-240-010	Start Cable (J911) 25' (req PLA)
101-240-168	Start Cable (J911) 50' (req PLA)
101-240-072	Start Cable (J913) 25' (no PLA req)
101-240-017	RF, non-CE - 8' (J931S)
101-240-012	RF, non-CE - 15' (J931S)
101-240-007	RF, non-CE - 25' (J931S) Note: Not for 30kHz or 40kHz systems
101-240-200	RF, non-CE - 50' (J931) Note: Not for 30kHz or 40kHz systems
101-240-034	RF, non CE - 8' (J 934)
101-240-035	RF, non CE - 15' (J934)
101-240-081	RF, non CE - 8' (J936S)
101-240-069	RF, non CE - 15' (J936S)
101-240-080	RF, non CE - 25' (J936S)
101-240-176	RF, CE - 8' (J931CS)
101-240-177	RF, CE - 15' (J931CS)
101-240-178	RF, CE - 25' (J931CS) Note: Not for 30kHz or 40kHz systems
101-240-199	RF, CE - 50' (J931C)
101-240-179	RF, CE - 8' (J934C)
101-240-188	RF, CE - 15' (J934C)
101-240-182	RF, CE - 20' (J934C)
100-246-630	Ground Detect Cable
100-143-043	Printer, 6'

4.4 Installation Requirements

4.4.1 Location

The actuator or stand may be installed in a variety of positions. The stand (on a base) is often manually operated, using its base-mounted start switches, and so is installed at a safe and comfortable workbench height (approximately 30-36 inches) with the operator sitting or standing in front of the system. Stands (on hubs) are often used in automated systems and may be manually or automatically loaded and unloaded.



WARNING

The stand may tip over if moved around the axis of its column, if not properly secured. The work surface on which a stand is installed must be sturdy enough to support it, and secure enough to not tip over when the stand is adjusted during installation or setup.

The power supply may be located up to 50 feet away for 20kHz, (20' for 30kHz, and 15' for 40kHz models) from the actuator. The power supply must be accessible for user parameter changes and settings, and must be placed in a horizontal orientation. The power supply should be positioned so it does not draw in dust, dirt or material via its rear fans. See [Figure 4.4 'Power Supply Dimensional Drawing' on page 4 - 12](#).

4.4.2 Environmental Specifications

Table 4.3 *Environmental Specifications*

Environmental Concern	Acceptable Range
Humidity	Maximum non-condensing
Operating Altitude	Up to 6560 ft (2000 m)
Ambient Operating Temperature	+5°C to +50°C (41°F to 122°F)
Storage / Shipping Temperature	-25°C to +55°C (-13°F to +131°F); Up to +70°C (+158°F) for 24 hours

4.4.3 Electrical Input Power Ratings

Plug the Power Supply into a single-phase, grounded, 3-wire, 50 or 60 Hz power source. [Table 4.2](#) lists the current and fuse ratings for the various models.

The ground screw on the rear of the actuator must be connected to earth ground with #8 gauge wire.

Table 4.4 *Input Power requirements*

For 20 kHz models	1250 W 200V - 240V	7 Amp Max. @ 200V / 20 Amp fuse	NEMA L6-20P Plug
	1250 W 100V - 120V	14 Amp Max. @ 100V / 20 Amp fuse	NEMA 5-15P Plug
	2500 W 200V - 240V	14 Amp Max. @ 200V / 20 Amp fuse	NEMA L6-20P Plug
	4000 W 220V - 240V	25 Amp Max. @ 220V / 25 Amp fuse	NEMA L6-20P Plug
For 30 kHz models	750 W 100V - 120V	10 Amp Max. @ 100V / 20 Amp fuse	NEMA 5-20P Plug
	750 W 200V - 240V	5 Amp Max. @ 200V / 20 Amp fuse	NEMA L6-20P Plug
	1500 W 100V - 120V*	26 Amp Max. @ 100V / 20 Amp fuse	NEMA 5-20P Plug
	1500 W 200V - 240V	10 Amp Max. @ 200V / 20 Amp fuse	NEMA L6-20P Plug
For 40 kHz models	400 W 200V - 240V	3 Amp Max. @ 200V / 20 Amp fuse	NEMA L6-20P Plug
	400 W 100V - 120V	5 Amp Max. @ 100V / 20 Amp fuse	NEMA 5-15P Plug
	800 W 200V - 240V	5 Amp Max. @ 200V / 20 Amp fuse	NEMA L6-20P Plug
	800 W 100V - 120V	10 Amp Max. @ 100V / 20 Amp fuse	NEMA 5-15P Plug

* requires a special 20 amp 120V receptacle

4.4.4 Air Cylinder Consumption

Cubic Feet of air per minute per inch of stroke length (each direction)

Air Pressure	10	20	30	40	50	60	70	80	90	100
1.5"	0.00174	0.00243	0.00312	0.00381	0.00450	0.00513	0.00590	0.00660	0.00730	0.00800
2"	0.00317	0.00437	0.00557	0.00677	0.00800	0.00930	0.01040	0.01170	0.01300	0.01420
2.5"	0.00490	0.00680	0.00870	0.01060	0.01250	0.01440	0.01630	0.01830	0.02040	0.02230
3"	0.00680	0.00960	0.01240	0.01520	0.01800	0.02080	0.02350	0.02670	0.02910	0.03190

Use the table above to calculate the air used by the air cylinder.

Add 0.034 cubic foot per second (2CFM) of actual weld time to account for converter cooling air per weld cycle.

Example:

3.0" aed actuator running at full pressure (100psi) and stroke length (4") at a cycle rate of 20 parts per minute = 0.0319 CFM per inch of stroke (from table) x 8" (total stroke is 4" down and 4" back) equals 0.2552 CFM per stroke.

Weld time is 1 second so: $0.034 \times 1 = 0.034$ CFM for cooling.

Add 0.2552 CFM for cylinder to 0.034 CFM for cooling equals 0.2892 CFM per cycle. Multiply by 20 (parts per minute) for a total of 5.784 CFM.

The example above is to be considered a worst case condition for a welder to run at.

The 2000Xf/aef welding system is unique since it's pneumatics are used in a differential mode of operation. For this reason, use the 1000psi values from the above table to be on the conservative side for sizing airflow, rather than on the actual force values. Be sure to add the converter cooling value, 0.034.

Figure 4.4 Power Supply Dimensional Drawing

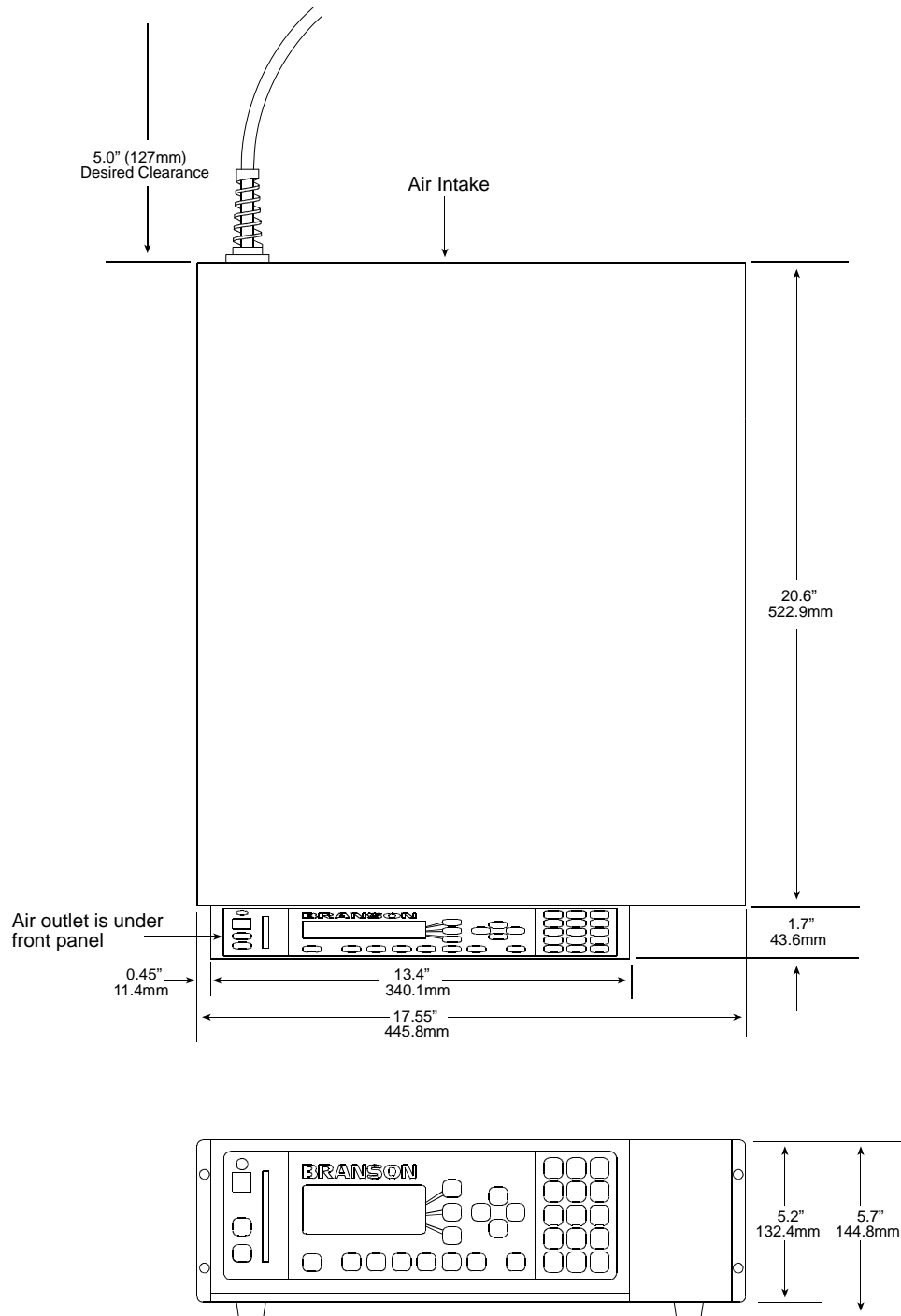

Figure 4.5 ao Actuator Dimensional Drawing

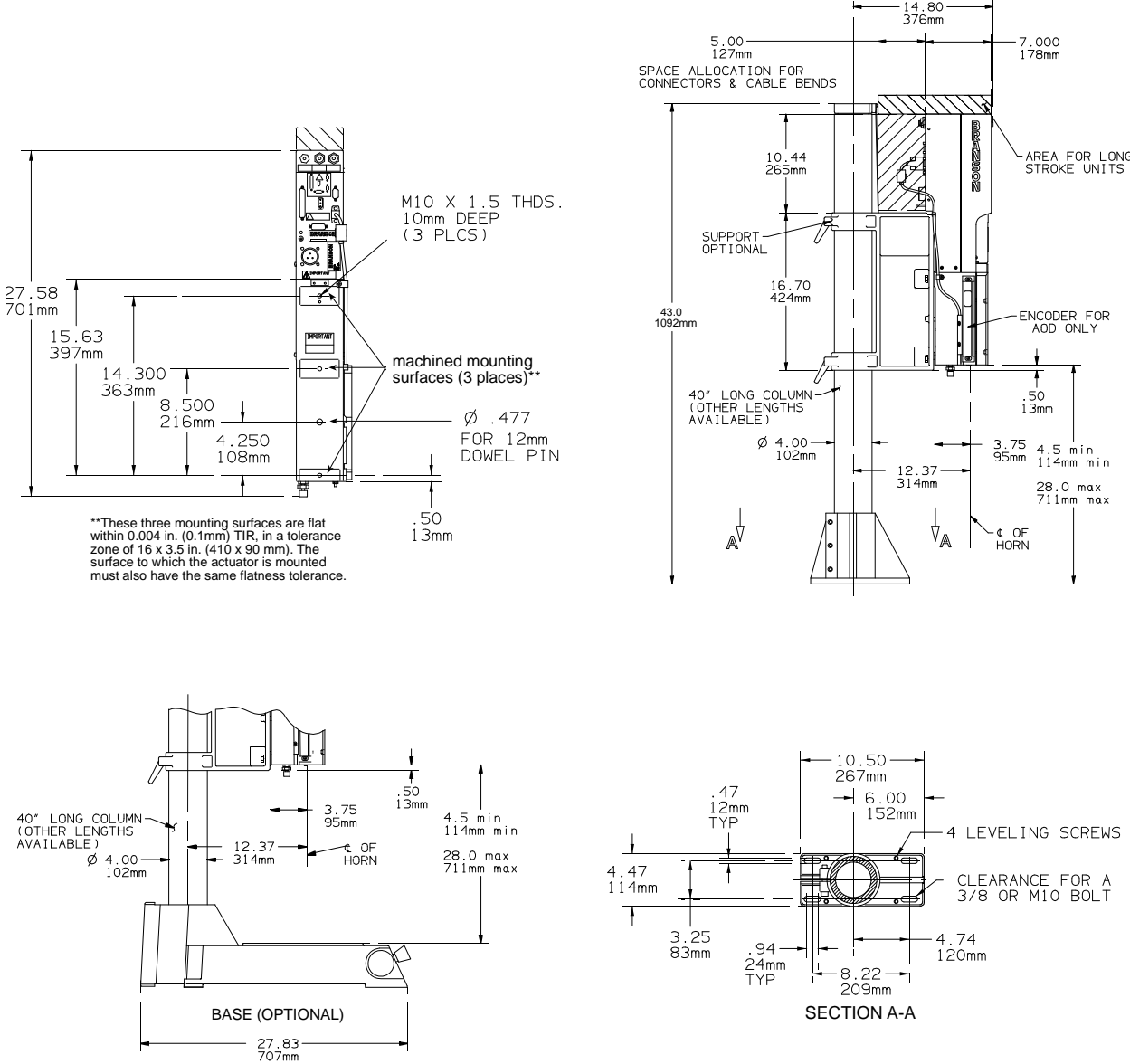
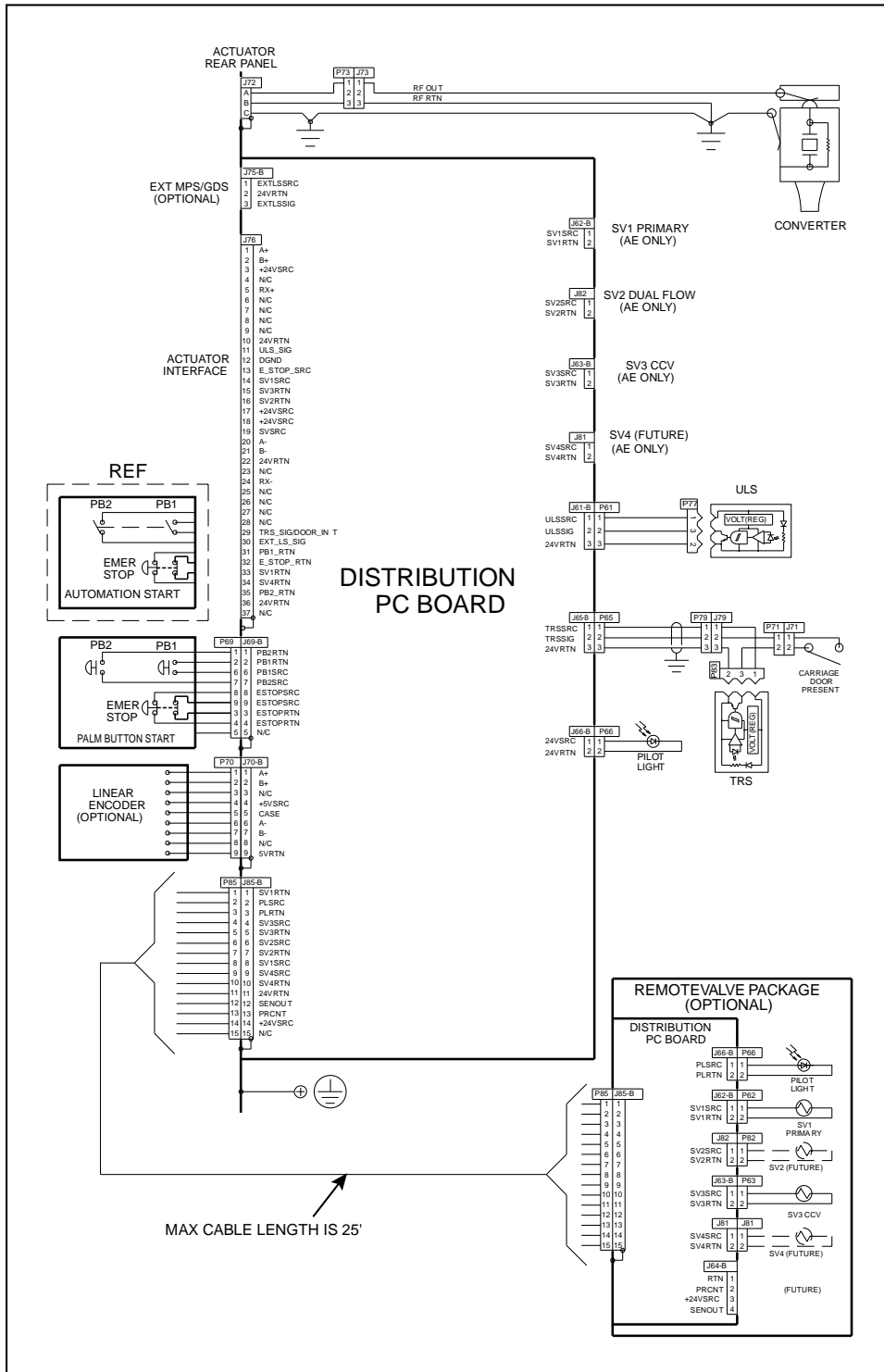

Figure 4.6 Block Wiring Diagram



4.4.5 Factory Air

The factory compressed air supply must be “clean (to a 5 micron level), dry and unlubricated” air with a regulated maximum pressure of 100 psig (690 kPa). Depending on your application, the actuator requires between 35 to 100 psi. Stands include an in-line air filter. Actuators (alone) require a customer-provided air filter. A quick-disconnect fitting is suggested. Use a lockout device on the air line if required.



WARNING

Synthetic air compressor lubricants containing Silicone or WD-40 will cause internal actuator damage and failure due to the solvents contained within these types of lubricants.

4.4.5.1. Air Filter

Actuators (alone) require a customer-provided air filter which protects from particulate matter of 5 microns or larger. If a stand is mounted in a position other than upright (vertical), its air filter must be relocated and oriented so its bowl is the lowest point, and the air flow across the air filter is horizontal. This may require some re-plumbing of the existing equipment at the customer site. The air filter is held in place by two screws on a bracket bolted to the column support, and by the factory-installed tubing. For further information, see your Actuator manual.

4.4.5.2. Pneumatic Tubing and Connectors

Actuator assemblies are not externally plumbed from the factory, but provide conventional 1/4-inch OD pneumatic tubing connection at the air inlet. If making connections for an actuator, or if re-plumbing your system for a new air filter location, you must use 1/4-inch OD tubing and connectors rated above 100 psi (use Parker "Parflex" 1/4 OD x .040 wall, type 1, grade E5, or equivalent), and appropriate connectors.

4.4.5.3. Pneumatic Connections to Actuator

Pneumatic connections to the aod actuator are identified as cylinder top, cylinder bottom, and cooling. The remote box houses the main air inlet along with the 3 output air connections to the actuator. Refer to Chapter 5 for a Pneumatic Schematic.



WARNING

Filtered cooling air must be provided to the actuator either from the rp box or from the customers custom pneumatics. Failure to connect cooling air may void product warranty. Consult with a Branson representative if you have any questions.

You must provide an air filter assembly to the remote box which will support at least 100 psig and remove particulate matter of 5 microns or larger.

4.5 Installation Steps



WARNING

This product is heavy and can cause a pinching or crushing injury during installation or adjustment. Keep clear of moving parts and do not loosen clamps unless directed to do so.



CAUTION

If a stand is not mounted in a vertical position, the air filter (on the column support) must be removed, reoriented, and replumbed. Failure to do so can cause air filter failure, and actuator failures.

4.5.1 Mounting the Stand (Actuator on Base)

The base must be bolted to your workbench to prevent tipping or undesired movement. Four mounting bolt holes are provided at the corners of the casting, and will accept your 3/8 inch or M10 cap screws. Use flat washers against the metal casting to prevent gouging.



CAUTION

You must secure the base to your work surface using four bolts, to prevent tipping or undesired movement, in the event the actuator is moved off-center or rotated around the column.

1. Ensure there are no overhead obstructions and that no pinch or rub points exist. Remember that the actuator is taller than the column when fully raised, and there are exposed connections.
2. Mount the base to your workbench using four socket-head cap screws (customer provided, 3/8 inch or M10). Use flat washers against the metal casting to prevent gouging. The use of nylon lock nuts with your cap screws is suggested, to reduce loosening due to vibration and movement.
3. Connect factory air to the air hose on the stand (3/8 NPT male fitting on the hose). A quick-disconnect fitting is suggested. Use a lockout device on the air line if required.
4. Verify the base/start switch control cable is properly connected to the **back of actuator**.
5. Verify the linear encoder connector is properly connected to the **back of the actuator**.
6. Verify earth ground is connected with #8 gauge wire to the ground terminal on the rear of the actuator.

Figure 4.7 Base Mounting Centers

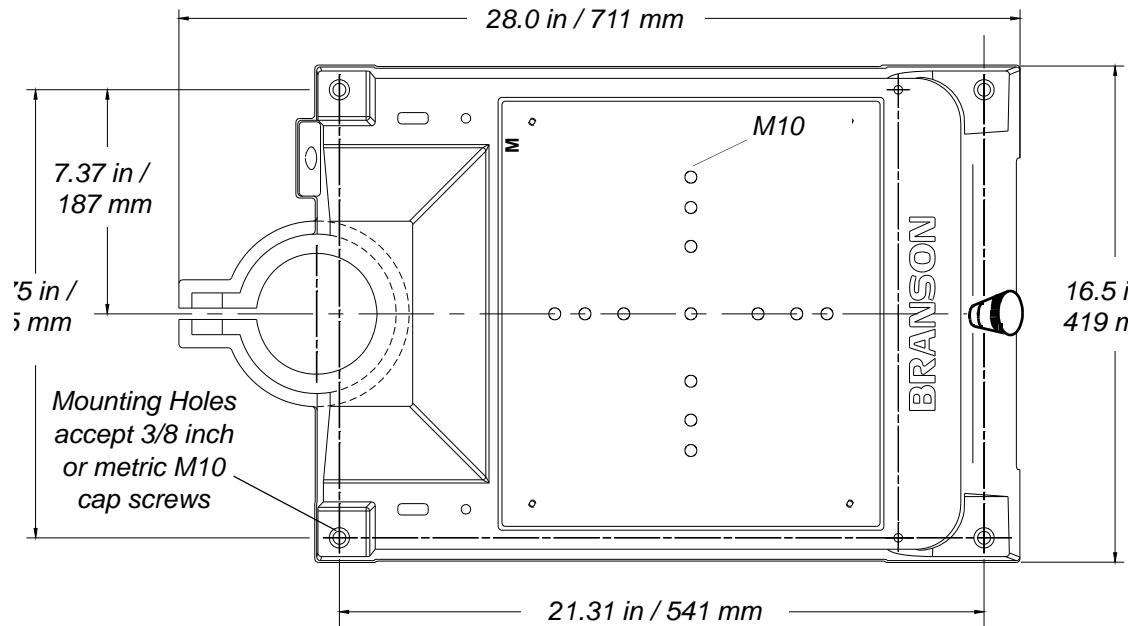

4.5.2 Mounting the Stand (Actuator on Hub-mounted column)

During unpacking, you removed the hub from the column/stand assembly. You must choose a mounting location for the hub that will support the column and actuator, and provide the hardware to mount it. Four mounting bolt holes are provided at the corners of the casting, and will accept your 3/8 inch or M10 hardware. Use flat washers against the metal casting to prevent gouging.



CAUTION

The hub must be installed with its front in the same direction as the front of the actuator. The column bolts of the hub are found on the rear of the hub. See *Section Figure 4.8, Mounting Bolt Pattern for the Hub (for Stand on Hub)*, on page 4-18 for mounting details.

Figure 4.8 Mounting Bolt Pattern for the Hub (for Stand on Hub)

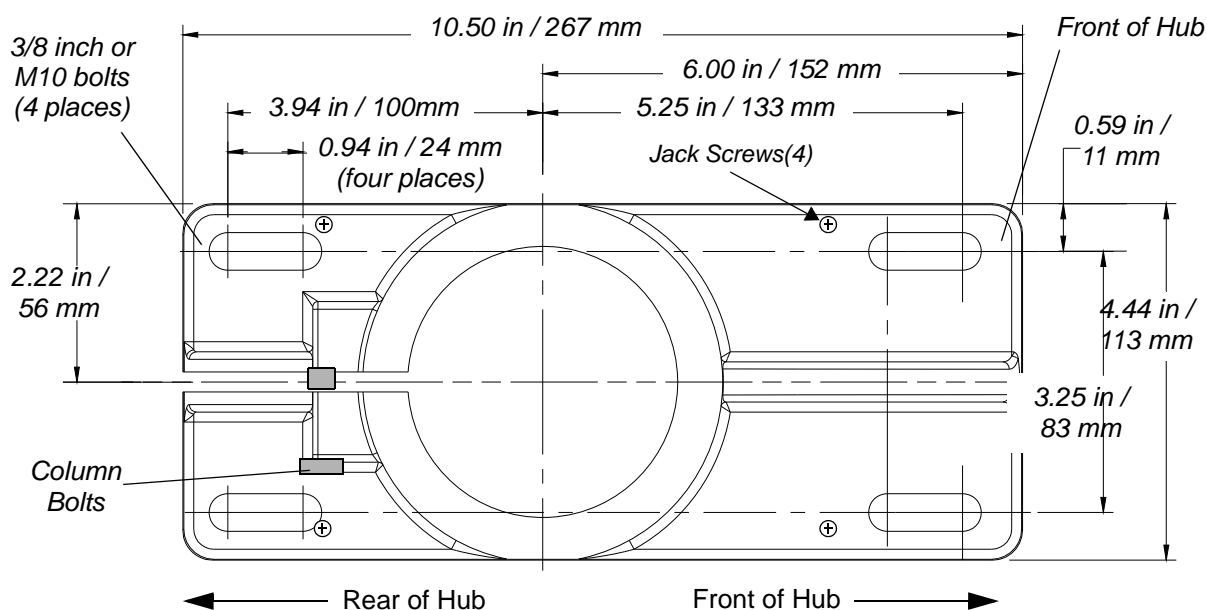

1. Locate the hub in the desired location. Ensure no overhead or side obstructions will interfere with normal operation or use of the system.



CAUTION

Mount the hub to your work surface using four bolts, 3/8-inch or M10 shank size, with flat washers against its metal casting (customer provided hardware).

2. Carefully lift the actuator and column assembly, and mount the column in the hub. Align the flat face of the spring swivel with the top-front of the actuator. Tighten the two bolts on the hub.
3. Connect factory air to the air hose on the stand (1/4 NPT male fitting on the hose). A quick-disconnect fitting is suggested. Use a lockout device on the air line if required.
4. Verify the base/start switch control cable is properly connected to the **back of actuator**.
5. Verify the linear encoder connector is properly connected to the **back of the actuator**.
6. Use jack screws to fine adjust the system level. A 3/16" allen wrench should be used for the 3/8"-16 x 3/4" jack screws.
7. Verify earth ground is connected with #8 gauge wire to the ground terminal on the rear of the actuator.

4.5.3 Actuator (Alone)

The actuator (alone) is intended for installation on your custom-made mounting support. It is located in place with a mounting pin and secured using three metric bolts.



CAUTION

In a custom installation, the actuator must be mounted on an I-beam or other rigid structure. The mounting surface must be flat within 0.004 in (0.1mm) Total Indicator Reading, in a tolerance zone of 16 x 3.5 in (410 x 90 mm).

1. Lift the actuator from the box. Carefully lay the assembly on its right side (NOT on the side with the linear encoder).
2. Use of a guide pin is suggested. It is not provided with the actuator. If you require a guide pin, use a solid metal dowel pin, 12mm diameter, which must not extend into the actuator more than 0.40 inch (10mm) from your support.



CAUTION

The actuator support bolts for the 2000X-Series actuators are metric, M10 x 1.5 thread pitch, 25mm long. The support pin and mounting bolts must not extend more than 0.40 in (10 mm) into the actuator, otherwise, binding or damage to the carriage may occur.



CAUTION

DO NOT use 900-Series M10 x 1.25 mounting bolts. They have a different thread pitch and will not interchange with those used on the 2000X-Series

Figure 4.9 Rear view of Actuator, showing Mounting Surface, Bolt and Guide Pin locations

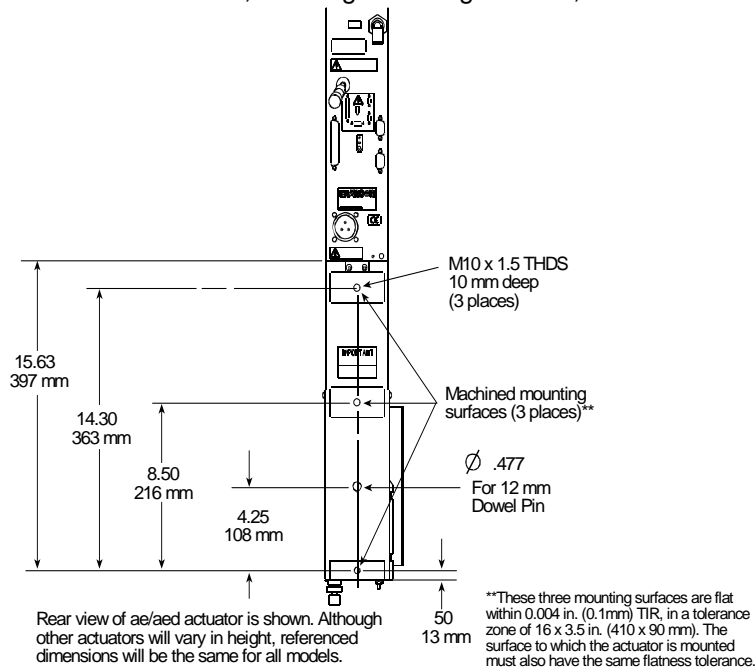

3. Lift the actuator assembly into position on your mount, and secure using the metric bolts provided.



CAUTION

In the event you must use bolts of a different length, ensure that the bolts extend more than 0.25 inch (6 mm) into the threads in the actuator housing, but less than 0.40 inch (10 mm).

4.5.4 Mount the Power Supply

The power supply is designed to be placed on a workbench (rubber feet on bottom) within cable-length limits of the actuator, or it may be rack-mounted in a standard 19-inch Rack (using an optional rack mount handle kit). It has two rear-mounted fans which draw cooling air from rear to front, which must be free from obstruction. Do not place the power supply on the floor or in other locations that will allow dust, dirt or contaminants to be drawn into the power supply.

The controls on the front of the power supply must be accessible and readable for setup changes.

All electrical connections are made to the rear of the power supply, which should be positioned in your workspace with adequate clearance (approximately 4 inches or more on either side, and 6 inches to the rear) for cable access and ventilation. Do not place anything on top of the power supply case.

In the event the system is to be installed in a high dust environment, the use of a fan filter kit (101-063-614) is required.

See [Figure 4.4 on page 4-12](#) for a dimensional drawing of the 2000 Series Power Supply.

Figure 4.10 Connections on Rear of Power Supply

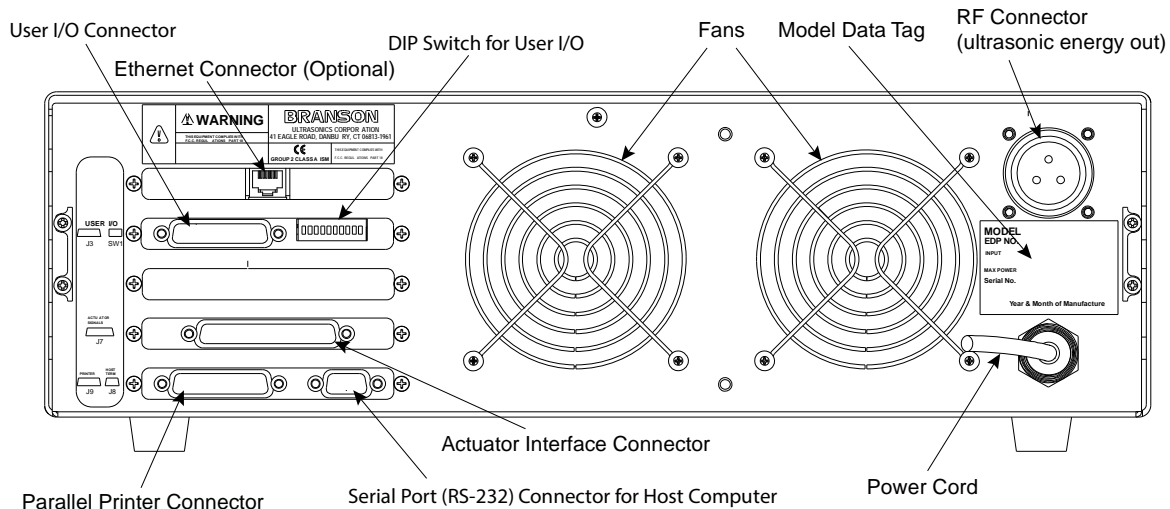

The cable lengths are limited based on the operating frequency of the welding system. Performance and results can suffer if the RF cable is crushed, pinched, damaged or modified. Contact your Branson Representative if you have special cable requirements. In some cases, remote operation from a User I/O or a Host Computer can be used to solve a distance limitation.

4.5.5 Input Power (Main)

The system requires single-phase input power, which you connect to the Power Supply using the integral power cord. See “Table 4.4, Input Power Requirements” for plug and receptacle requirements for your specific power level.

Refer to the unit’s Model Data Tag to be sure of the power rating of the Model in your system.

4.5.6 Output Power (RF Cable)

Ultrasonic Energy is delivered to a screw-on MS receptacle connection on the rear of the Power Supply, which is connected to the Actuator or the Converter (depending on your application).



WARNING

Never operate the System with the RF Cable disconnected or if the RF Cable is damaged.

4.5.7 Interconnect between Power Supply and Actuator

The Branson 2000Xao Actuator has two electrical connections between the Power Supply and the Actuator: the RF Cable and the Actuator Interface cable. A 37-pin cable is used for Power and Control Signalling between the Power Supply and a Branson Actuator. The cable connects to the rear of the Power Supply and the rear of the Actuator.

There can be other connections to the Actuator, and other connections to the Power Supply, but these are the only two standard connections, depicted in [Figure 4.11](#).

For ground detect use, to have ultrasonic energy turn off when the horn comes in contact with your electrically isolated fixture or anvil, it is necessary to install Branson cable EDP No. 100-246-630 from the MPS/GDS receptacle on the rear of the actuator to your isolated fixture/anvil in order to utilize this feature.

Figure 4.11 Electrical Connections from Power Supply to a 2000-series Actuator

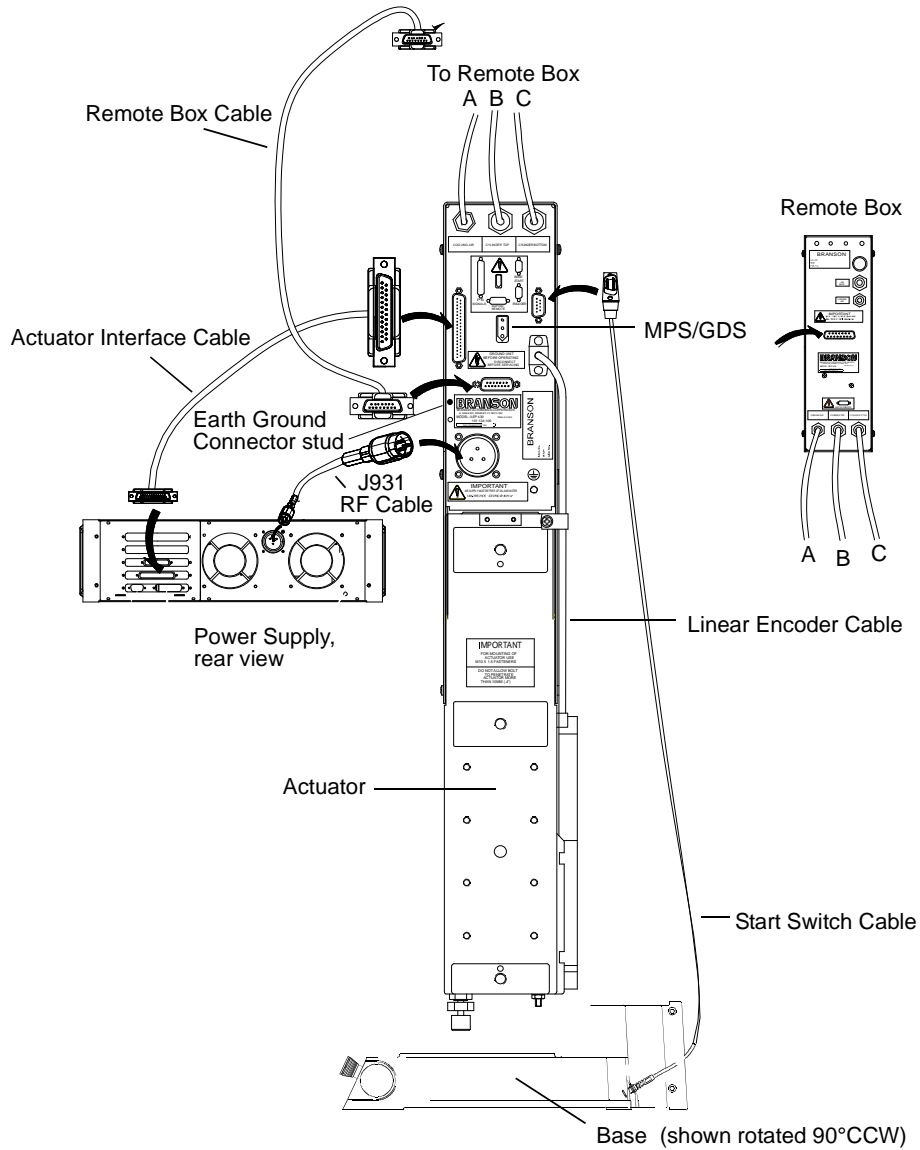

4.5.8 Start Switch Connection (Automation)

A Branson actuator requires two start switches and emergency stop connection. Stands on a base include this connection (factory installed and connected from the base) while the stand on a hub and actuator (alone) applications require the user make their own start switch/E-stop connections, as follows:

Figure 4.12 Start Switch Connection Codes

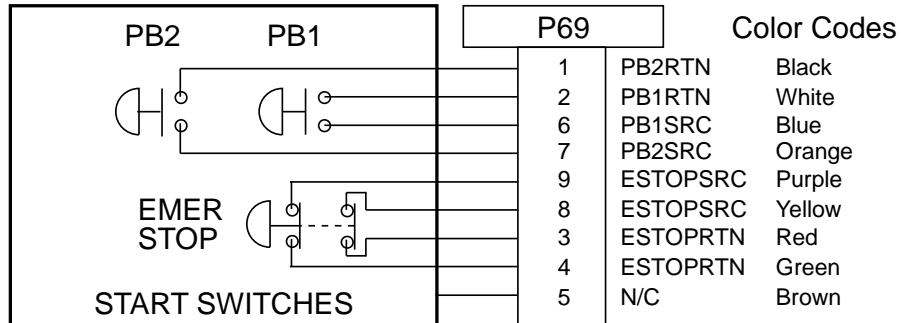

NOTE

Solid state devices may be used in lieu of mechanical start switches providing their leakage current does not exceed 0.1 mA.



NOTE

Start Switches PB1 and PB2 must be closed within 200 milliseconds of each other, and remain closed until the WELD ON signal is active, to effect a start condition.

BASE/START is the DB-9 female connection on the back of the actuator. Your cable requires a male DB-9 (D-shell) connector.

PB1 and PB2 are two normally open start-switches which must be operated simultaneously to start the welding cycle. These must be closed within 200 milliseconds of each other, or error message "Start Sw Time" will display. This doesn't require a reset, but for the next cycle, switches must be within time limit to preclude re-occurrence of error message. Refer to Note above.

EMER STOP is an emergency stop switch, normally closed.



NOTE

Refer to the Branson Automation Guide (EDP 100-214-273) for additional information about selection and use of Input and Output features.

4.5.9 Serial (RS-232) Port Connector

An RS-232c serial port (DB-9 format) is provided for the Host Computer option. Only three data leads of this port are supported at this time (Data Send TXD, Data Receive RXD, and Signal Ground GND). The remainder of the leads are 'reserved'. A null modem cable is required.

The comport parameters are fixed, can not be altered or viewed in the menu.

The fixed values are:

1. com speed = 9600 baud
2. no parity
3. 1 stop bit
4. 8 data bits

4.5.10 Parallel Printer Connector

The Printer Connector can support one printer model, to provide printed reports of your weld information, and to provide graphical representation of your weld results. The printer interface is for a dot-matrix printer, using a 9-pin printing head. One printer model is available from Branson at the present time.

4.5.11 User I/O Interface

The user I/O is a standard interface for automation, provided on the power supply. It provides the ability for the customer to make their own interface for their automation or special control or reporting needs. The interface cable has an HD44 female D-shell connection on the rear of the power supply. The electrical interface outputs may be configured for open collector mode or for signal mode (signal voltage levels as indicated), by setting the user I/O DIP switch.

DIP switch SW1 for the user I/O is located next to the J3 on the back of the 2000X-series power supply. User I/O interface cable pinout is listed in Table 4.5.

Figure 4.13 User I/O Cable Identification and Wire Color Diagram

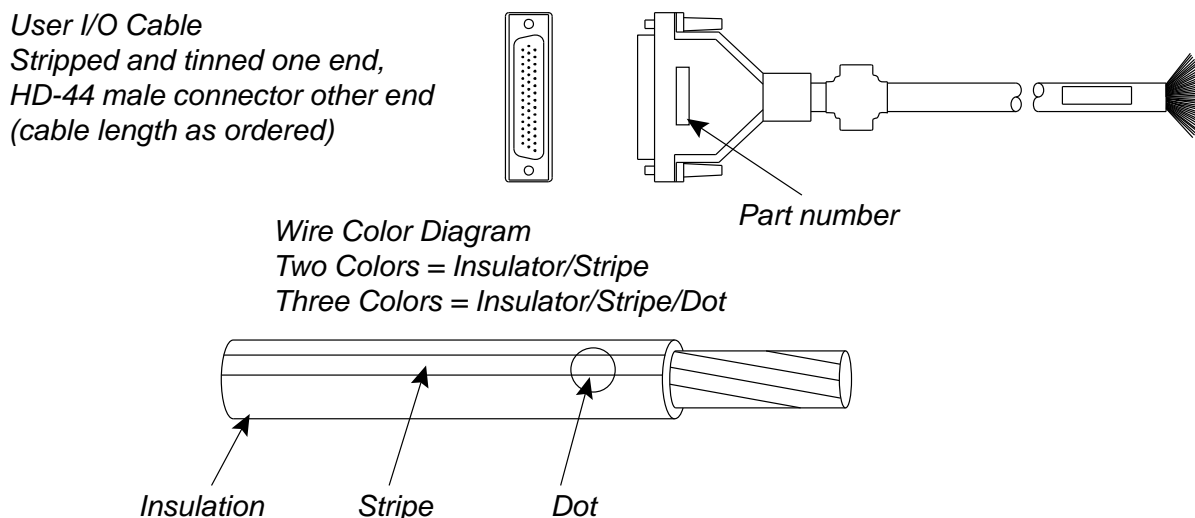

Table 4.5 User I/O Cable Pin Assignments.

Pin	Signal Name	Signal Type	Direction	Signal Range	Definition	Colors
7	ACT_CLEAR	0V True	Output	0/24V, 100mA	Actuator clear signal	Red/Wht
24	AMPLITUDE_OUT	Analog	Output	0V to 10V	Amplitude signal from PS	Red/Blk/ Grn
2	CYCLE_ABORT	24V True	Input	0/24V, 100mA		Red/Blk
3	EXT_RESET	24V True	Input	0/24V, 100mA	System Reset	Grn/Blk
18	EXT_SEEK+	24V True	Input	0/24V, 100mA		Red/Blk/ Wht
38	FREQ_OUT	Analog	Output	-10V to +10V	Frequency Signal from PS	Blk/Wht/Blu
6	G_ALARM	0V True	Output	0/24V, 100mA		Blk/Wht
14	GEN_ALARM_RELAY_1	Relay Contact	Output	40V, 0.25A	Contact Closure	Red/Grn
29	GEN_ALARM_RELAY_2	Relay Contact	Output	40V, 0.25A	Contact Closure	Wht/Red/ Orn
1	J3_1_INPUT	24V True	Input	0/24V, 100mA	User definable inputs. Refer to Table 4.6 to view available selections.	Wht/Blk
17	J3_17_INPUT	24V True	Input	0/24V, 100mA		Wht/Blk/ Red
19	J3_19_INPUT	24V True	Input	0/24V, 100mA		Grn/Blk/ Wht
31	J3_31_INPUT	24V True	Input	0/24V, 100mA		Wht/Red/ Blu
32	J3_32_INPUT	24V True	Input	0/24V, 100mA		Blk/Wht/ Grn
33	J3_33_INPUT	24V True	Input	0/24V, 100mA		Wht/Blk/ Grn
8	J3_8_OUTPUT	24V True	Output	0/24V, 100mA	User definable outputs. Refer to Table 4.7 to view available selections.	Grn/Wht
22	J3_22_OUTPUT	24V True	Output	0/24V, 100mA		Blk/Red/ Grn
36	J3_36_OUTPUT	24V True	Output	0/24V, 100mA		Orn/Red Grn
9	MEM	Analog	Output	-10V to +10V	Memory Signal from PS	Blu/Wht
11	MEM_CLEAR	Open Collector	Output	24V, 25mA max	Memory Clear signal send to PS	Wht/Red
40	MEMORY_STORE	Open Collector	Output	24V, 25mA max	Memory store from PS	Red/Wht/ Blu
34	PB_RELEASE	0V True	Output	0/24V, 100mA		Red/Wht/ Grn
37	PWR	Analog	Output	0V to 10V	Power Signal from PS	Blu/Red/ Grn
21	READY	0V True	Output	0/24V, 100mA		Blu/Blk/Wht
5	REJECT	0V True	Output	0/24V, 100mA		Blu/Blk
43	READY_RELAY_1	Relay Contact	Output	40V, 0.25A	Contact Closure	Blu/Orn/ Red
15	READY_RELAY_2	Relay Contact	Output	40V, 0.25A	Contact Closure	Orn/Grn
26	RUN	Open Collector	Output	24V, 25mA max	Run signal send to PS	Orn/Blk/Grn
39	SEEK	Open Collector	Output	24V, 25mA max	Seek Signal send to PS	Wht/Blk/Blu
4	SOL_VALVE_SRC	24V	Output	0/24V, 125mA	SV1 Source	Orn/Blk

Pin	Signal Name	Signal Type	Direction	Signal Range	Definition	Colors
16	SOL_VALVE_RTN	24V Return	Input	0V	SV1 Return	Blk/Wht/ Red
20	SUSPECT_PART	0V True	Output	0/24V, 100mA		Orn/Blk/ Wht
10	USER_AMP_IN	Analog	Input	-10V to +10V	User Amplitude control signal	Blk/Red
25	USER_FREQ_OFFSET	Analog	Input	-10V to +10V	User Freq. offset control signal	Grn/Blk/Orn
35	WELD_ON	0V True	Output	0/24V, 100mA	Start of sonics and trigger	Grn/Wht/ Blu
30	WELD_ON_RELAY_1	Relay Contact	Output	40V, 0.25A	Contact Closure	Orn/Wht/ Blu
44	WELD_ON_RELAY_2	Relay Contact	Output	40V, 0.25A	Contact Closure	Blk/Orn/ Red
23	+10V_REF	Analog	Output	10.0V	10VDC ref. voltage from PS	Wht/Red/ Grn
12	24V_RTN	24V Ground	Input	0V	24V Return	Orn/Red
13	24V_SRC	24V Source	Output	24V, 1.25A max	24V Source	Blu/Red
27	24V_RTN	24V Ground	Input	0V	24V Return	Blu/Wht/ Orn
28	24V_SRC	24V Source	Output	24V, 1.25A max	24V Source	Blk/Wht/ Orn
41	24V_RTN	24V Ground	Input	0V	24V Return	Grn/Orn/ Red
42	24V_SRC	24V Source	Output	24V, 1.25A max	24V Source	Orn/Red/ Blu



CAUTION

Ensure all unused wires are properly isolated. failure to do so may result in Power Supply or system failure.



NOTE

Refer to the Branson Automation Guide (EDP 100-214-273) for additional information about selection and use of Input and Output features listed in the following Table.

Table 4.6 User I/O Input and Output Function Selection

Input		Output	
J3_1_INPUT	Disabled	J3_8_OUTPUT	Disabled Confirm Preset Ext Beeper Cycle Okay No Cycle Alarm Overload Alarm Modified Alarm Note Missing Part External Start Sync Out
J3_17_INPUT	Ext U/S Delay	J3_22_OUTPUT	
J3_19_INPUT	Display Lock	J3_36_OUTPUT	
J3_31_INPUT	Ext Cycle Abort		
J3_32_INPUT	Sonics Disable		
J3_33_INPUT	Memory Reset		
	External Start		
	Ext Signal		
	Sync In		

4.5.12 Input Power Plug

If you must add or change the input power plug, use the following color code for the conductors found in the international harmonized line cord. Add the plug that is appropriate for your input power receptacle.



CAUTION

The power supply can be permanently damaged if it is connected to the incorrect line voltage, or if the wiring connection is mis-wired. It also presents a safety hazard if mis-wired. Use of the correct plug or connector helps prevent incorrect connections.

Figure 4.14 Line Cord Color Code

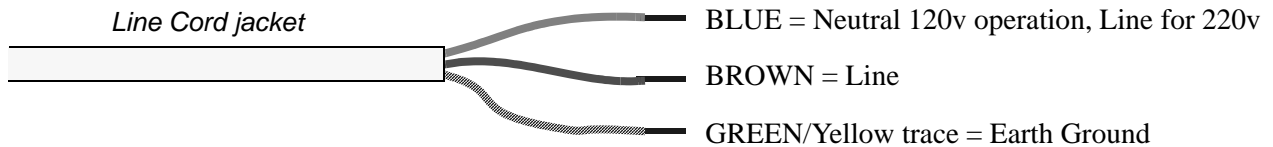

4.5.13 User I/O DIP Switch (SW1)

DIP switch SW1 for the user I/O is located next to the J3 on the back of the 2000X-series power supply. The settings of these switches affect the user I/O signals. Factory default setting is with all dip switches set to ON (switch position closest to number designation).

- If the dip switch is set to the ON (closed) position, the corresponding Output pin will be configured as the current source, 25mA max.
- If the dip switch is set to the OFF (open) position, the corresponding Output pin will be configured as an “open collector”, 24VDC, 25 mA max. current sink.

Table 4.7 User I/O DIP Switch Functions

Switch Position	Signal Description	Output Signal
1	$\overline{\text{REJECT_PART}}$	$\overline{\text{R_SIG}}$
2	$\overline{\text{SUSPECT_PART}}$	$\overline{\text{S_P_SIG}}$
3	$\overline{\text{PB_RELEASE}}$	$\overline{\text{PB_R_SIG}}$
4	$\overline{\text{G_ALARM}}$	$\overline{\text{G_A_SIG}}$
5	$\overline{\text{READY}}$	$\overline{\text{RDY_SIG}}$
6	$\overline{\text{WELD_ON}}$	$\overline{\text{W_O_SIG}}$
7	$\overline{\text{ACTUATOR_RETURN}}$	$\overline{\text{A_R_SIG}}$
8	$\overline{\text{USER_OUT1}}$	$\overline{\text{M_PART_SIG}}$
9	$\overline{\text{USER_OUT2}}$	$\overline{\text{U_OUT1_SIG}}$
10	$\overline{\text{USER_OUT3}}$	$\overline{\text{U_OUT2_SIG}}$

4.5.14 Module Options DIP Switch

In some configurations, it might be necessary to open the Power Supply and change the DIP (Dual In-line Package) switches on the power supply module. DIP switches change the Seek and Start functions and can affect the Amplitude Control functions. Refer to your Power Supply Instruction manual, or 2000X-Series Installation Guide for detailed information.



CAUTION

The components in the Power Supply are subject to damage from electro-static discharge. When working inside the Power Supply, use a grounded wrist strap and minimize your movement to reduce the possibility of damage due to static electricity.



WARNING

Unplug the Power Supply (if previously connected) and wait at least two (2) minutes before opening the Power Supply case. Hazardous Voltages exist and are stored in the system.

4.6 Guards and Safety Equipment

4.6.1 Emergency Stop Control

If you use the Emergency Stop button on the Actuator to terminate a weld, twist the button to reset it. (The welder will not operate until this button is reset.) You must then press Reset at the power supply. If you are running automation, you can use external reset that is connected to your User I/O board.

Figure 4.15 Actuator Emergency Stop Button

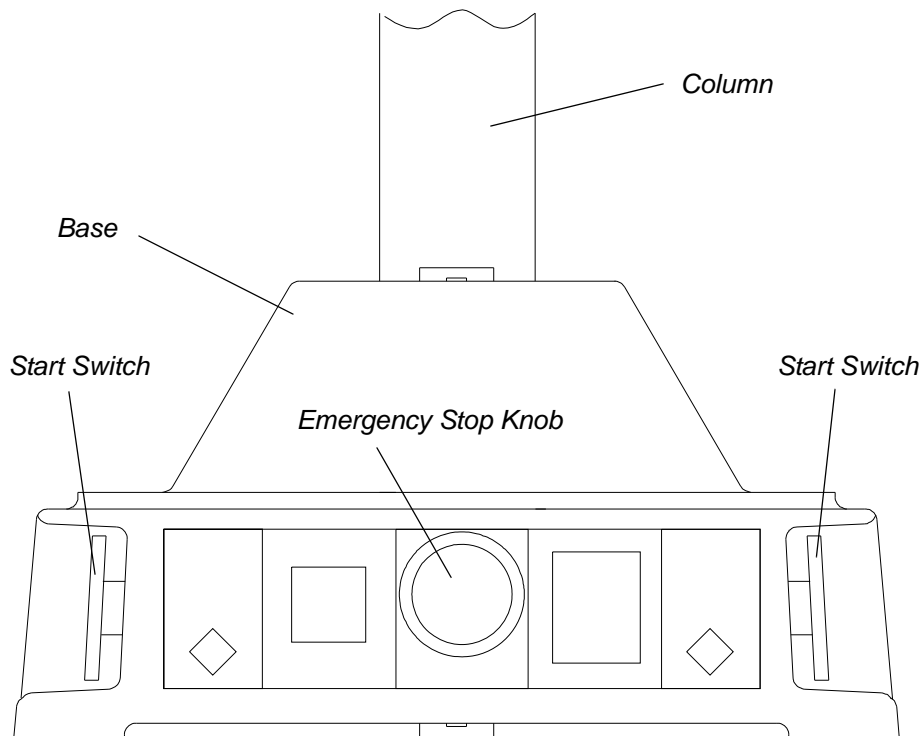

If you are using an Emergency Stop signal from the User I/O, you must clear the Emergency Stop condition before the System will operate.

4.7 Rack Mount Installation

If the system is Rack Mounted, you need to order the Rack Mount handle kit. The kit includes two rack mounting handles and two corner pieces, which support the handles and provide the rack mount interface.



CAUTION

The Rack Mount handle kit does NOT support the power supply in the rack. The weight of the power supply must be supported by integral brackets of the rack itself.



NOTE

Do not permanently remove the Cover from the Power Supply because it is required for proper system cooling.

Step	Procedure
1	Order and obtain the Rack Mount kit for your Power Supply. The brackets in the Kit are designed for standard 19-inch rack mounting options.
2	From the front corners of the Power Supply, remove the Front Corner bezels by removing the two Phillips screws. Save the screws.
3	Noting that one side of each bracket is countersunk to accept the provided flathead screws, assemble the Rack Mount Handles as shown in Figure 4.16 'Detail of Rack Mount Handle Kit Assembly' on page 4 - 30 . (This shows only the Right bracket and handle; the left side is a mirror-image.) Tighten the screws securely and so they are flush.
4	Re-using the screws you removed in Step 2, install the assembled Handle in place of the Front Corner pieces.
5	Save the removed hardware corner pieces.
6	When you are ready to install the unit, use the hardware from your Rack Mounting system to locate the Power Supply.

Figure 4.16 Detail of Rack Mount Handle Kit Assembly

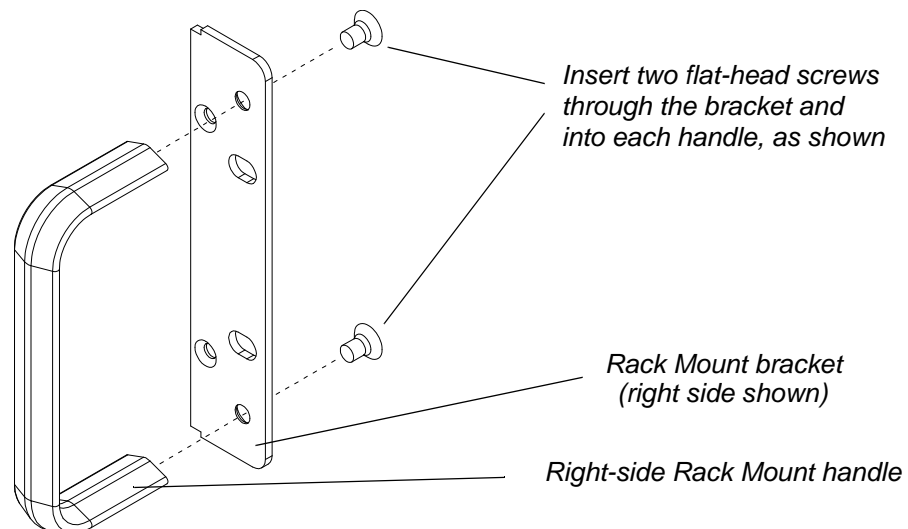

4.8 Assemble the Acoustic Stack



CAUTION

The following procedure must be performed by a setup person. If necessary, secure the largest portion of a square or rectangular horn in a soft jawed (brass or aluminum) vise. NEVER attempt to assemble or remove a horn by holding the converter housing or the booster clamp ring in a vise.



CAUTION

Do not use silicone grease with Mylar washers. Use only 1 (one) Mylar washer of the correct inside and outside diameters at each interface.

Table 4.8 Tools

Tool	EDP Number
15, 20, and 30 kHz Torque Wrench Kit	101-063-787
40 kHz Torque Wrench	101-063-618
15 kHz spanner Wrench	201-118-034
20 kHz Spanner Wrench	101-118-039
30 kHz Spanner Wrench	201-118-033
40 kHz Spanner Wrench	201-118-024
Silicone Grease	101-053-002

4.8.1 For a 20kHz System

Step	Action
1	Clean the mating surfaces of the converter, booster, and horn. Remove any foreign material from the threaded holes.
2	Install the threaded stud into the top of the booster. Torque to 450 in-lbs, 50.84 Nm. If the stud is dry, apply 1 or 2 drops of a light lubricating oil before installing.
3	Install the threaded stud into the top of the horn. Torque to 450 in-lbs, 50.84 Nm. If the stud is dry, apply 1 or 2 drops of a light lubricating oil before installing.
4	Install a single Mylar washer (matching the size of the washer to the stud) to each interface.
5	Assemble the converter to the booster and the booster to the horn.
6	Torque to 220 in-lbs, 24.85 Nm.

4.8.2 For a 30kHz System

Step	Action
1	Clean the mating surfaces of the converter, booster, and horn. Remove any foreign material from the threaded holes.
2	Apply a drop of Loctite® ¹ 290 threadlocker (or equivalent) to the studs for the booster and horn
3	Install the threaded stud into the top of the booster; torque to 290 in-lbs, 32.76Nm, and let cure for 30 minutes.
4	Install the threaded stud into the top of the horn; torque to 290 in-lbs, 32.76 Nm, and let cure for 30 minutes
5	Install a single Mylar washer (matching the size of the washer to the stud) to each interface.
6	Assemble the converter to the booster and the booster to the horn.
7	Torque to 185 in-lbs, 21Nm.

1. Loctite is a registered trademark of Henkel Corporation, U.S.A.

4.8.3 For a 40kHz System

Step	Action
1	Clean the mating surfaces of the converter, booster, and horn. Remove any foreign material from the threaded holes.
2	Apply a drop of Loctite 290 threadlocker (or equivalent) to the studs for the booster and horn.
3	Install the threaded stud into the top of the booster; torque to 70 in-lbs, 7.9 Nm, and let cure for 30 minutes.
4	Install the threaded stud into the top of the horn; torque to 70 in-lbs, 7.9 Nm, and let cure for 30 minutes.
5	Coat each interface surface with a thin film of silicon grease – <i>but do not apply silicon grease to a threaded stud or tip.</i>
6	Screw the converter to the booster.
7	Torque to 95 in-lbs, 10.7 Nm.
8	Slide the booster/horn assembly into the adapter sleeve. Screw on the adapter sleeve ring nut and leave loose.
9	Screw the booster onto the horn.
10	Repeat Step 7.
11	Securely tighten the adapter sleeve ring nut.

4.8.4 Assembling the 20kHz Acoustic Stack

(Shown with Rectangular Horn Secured in the Vise.)

Figure 4.17 Assembling the 20kHz Acoustic Stack

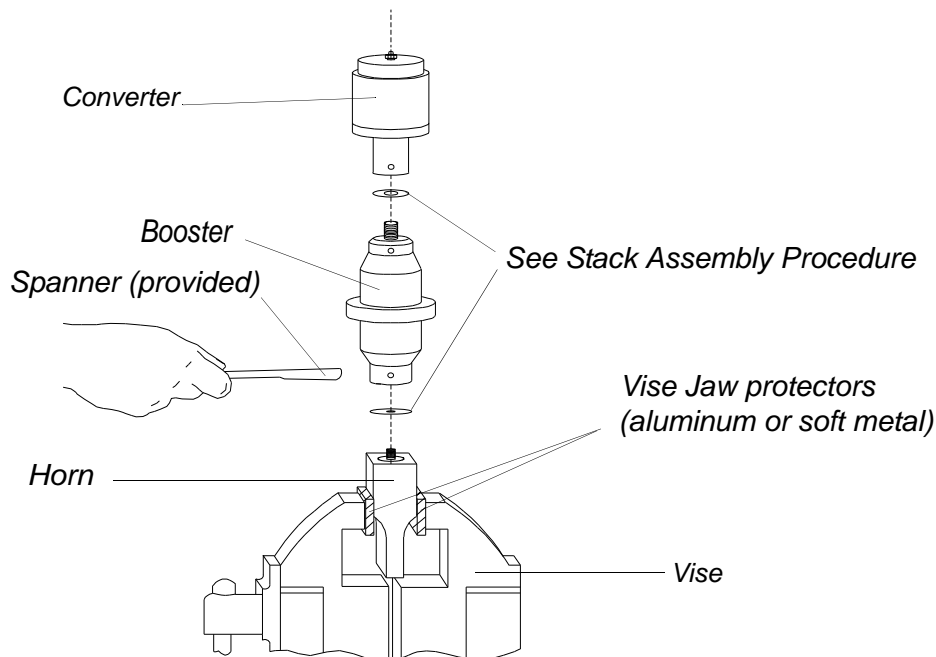

Stack Assembly Torque Table



NOTE

The use of a Branson torque wrench or the equivalent is recommended. P/N 101-063-617 for 20kHz systems and 101-063-618 for 40kHz systems.

Table 4.9 Stud Torque Values

Used On	Stud Size	Torque	EDP #
20 kHz	1/2" x 20 x 1-1/4"	450 in.-lbs, 50.84 Nm.	100-098-370
20 kHz	1/2" x 20 x 1-1/2"	450 in.-lbs, 50.84 Nm.	100-098-123
30 kHz	3/8" x 24 x 1"	290 in.-lbs, 32.76 Nm.	100-298-170
40 kHz	M8 x 1.25	70 in.-lbs, 7.90 Nm.	100-098-790

* Add a drop of Loctite 290 threadlocker to the stud. Torque and let cure for 30 minutes before use.

4.8.5 Connecting Tip to Horn

1. Clean the mating surfaces of the horn and tip. Remove foreign matter from the threaded stud and hole.
2. Hand assemble the tip to the horn. Assemble dry. Do not use any silicone grease.
3. Use the spanner wrench and an open-end wrench (refer to Figure 4.18) and tighten to the Torque tip specifications in [Table 4.10](#).

Figure 4.18 Connecting Tip to Horn

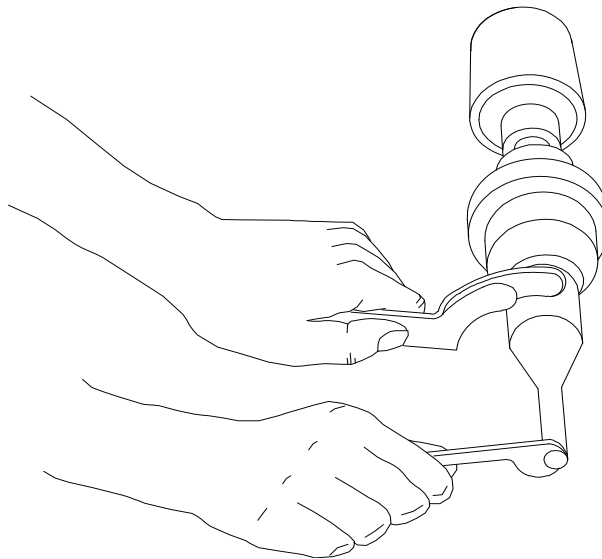

Table 4.10 Tip to Horn Torque Specifications

Tip Thread	Torque
1/4 - 28	110 in.-lbs, 12.42 Nm.
3/8-24	180 in.-lbs, 20.33 Nm.

4.8.6 Installing the Stack in the Actuator

20 kHz and 30kHz CA-30 Stacks

The ultrasonic stack must first be assembled. To install the stack:

1. Make sure that the system power is turned off by disconnecting the power plug.
2. Loosen the four door screws.
3. Pull the door straight off and set it aside.
4. Take the assembled ultrasonic stack and align the ring on the booster just above the support washer in the carriage. Firmly push the stack into place, with the acorn nut on the top of the converter making contact with the contactor in the top of the carriage.
5. Reinstall the door assembly, and start the four door screws.
6. Align the horn by rotating it, if necessary. Torque the carriage door to 20 in.-lbs to secure the stack.

Figure 4.19 Installing a 20kHz Stack in a Branson Actuator

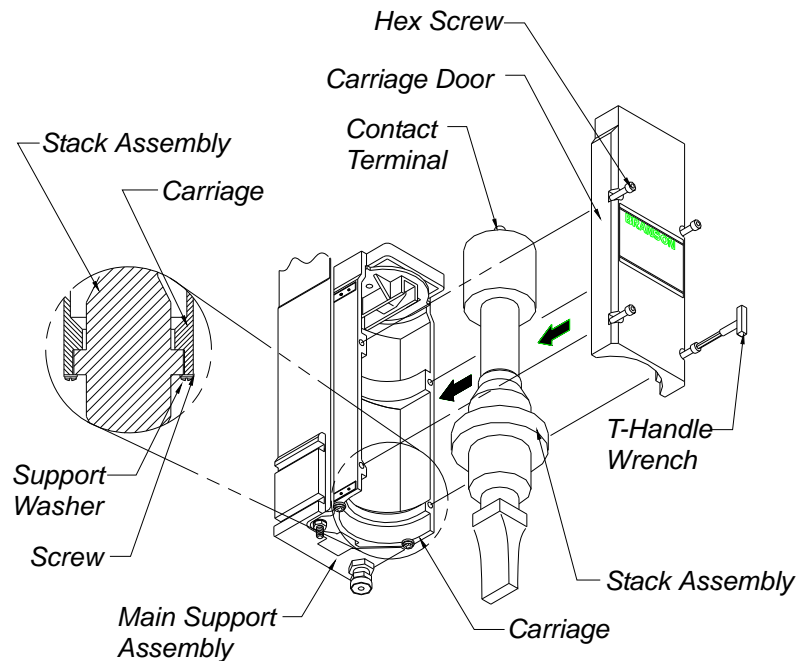

40 kHz Stacks

1. Make sure that the system power is turned off by disconnecting the power plug.
2. Place the converter / booster in the sleeve.
3. Loosen the four carriage door screws.

Figure 4.20 Installing a 40kHz Stack in a Branson Actuator

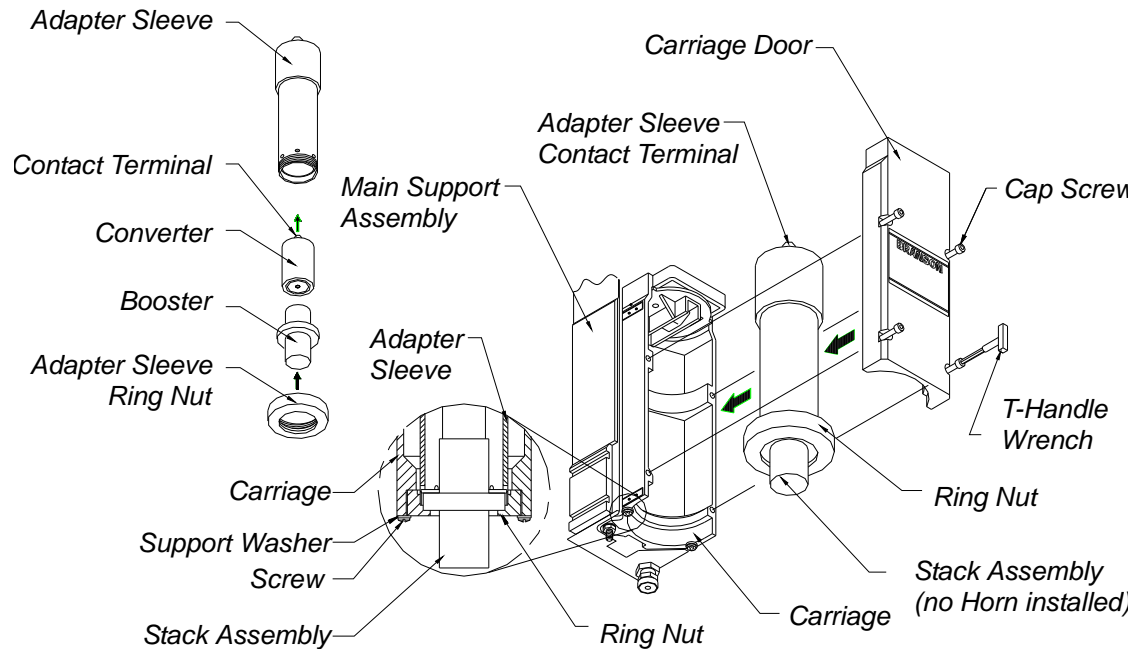

4. Pull the door straight off and set it aside.



CAUTION

Do not attempt to hold the sleeve in a vise. It can be easily crushed or damaged.

5. Take the assembled sleeve and align the ring nut on the booster just above the support washer in the carriage. Firmly push the sleeve into place, with the acorn nut on the top of the converter making contact with the contactor in the top of the carriage.
6. Reinstall the door assembly, and start the four door screws.
7. Align the horn by rotating it, if necessary. Torque the carriage door to 20 in.-lbs to secure the stack.

4.9 Mounting the Fixture on the Branson Base

(hardware and mounting holes)

The base provides mounting holes for your fixture. Mounting holes are also provided for the optional Branson leveling plate kit. The base is tapped for metric M10 hardware (indicated by an “M” on the base). The mounting holes are arranged in three concentric bolt circles with the following dimensions.



CAUTION

The base is cast metal and the mounting holes can become stripped if the hardware is overtightened. Tighten your hardware only enough to prevent movement of your fixture.

Figure 4.21 Mounting Circles on Base

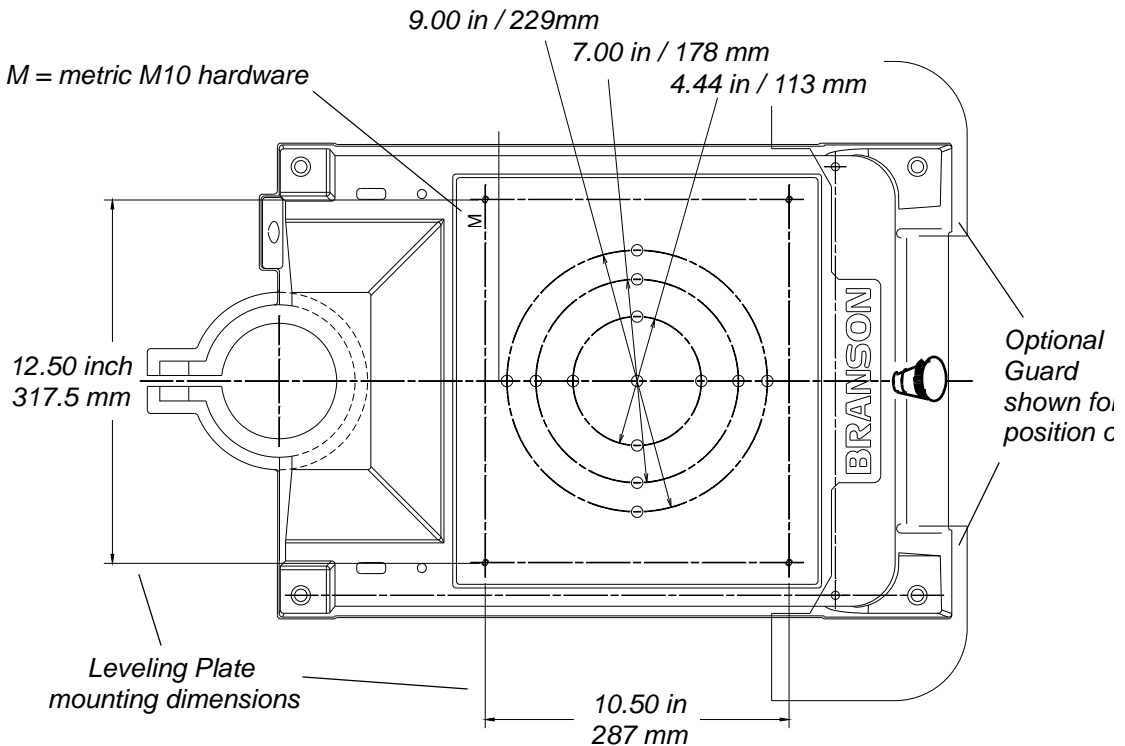

The optional guard, EDP 101-063-550, (sometimes required with very large horns) is shown for position only. It extends several inches to either side of the base, and prevents the user from operating the welder and pinching their fingers or hands between the base and the tooling.

4.10 Testing the Installation

1. Turn on the air supply connections with the air pressure regulator set at minimum values, and verify that the system has air pressure.
2. Ensure there are no leaks in the air supply connections.
3. Turn on the power supply. The power supply will begin its normal self-check.
4. If the power supply displays an alarm message, find the alarm message definition, cause and correction in Chapter 7 of this manual.
5. Press the **Test** button.
6. If the power supply displays an alarm message at this point, find the alarm message definition in the Maintenance section of Chapter 7 of the power supply manual. If there are no alarm messages displayed, go on to the next step.
7. Fit a test part onto the fixture.
8. Press the **Horn Down** key and then press and hold the two start switches. The horn will descend to the fixture on the base of the Actuator. This verifies specifically that the pneumatic system is working.
9. Press the **Horn Down** key again. The horn will retract. The system should now be functional and can be set up for your application.

In summary, if the power supply does not display an alarm message and the actuator descends and retracts correctly, your ultrasonic welder is ready for operation.

Figure 4.22 Normal Front Panel Display After Power-Up

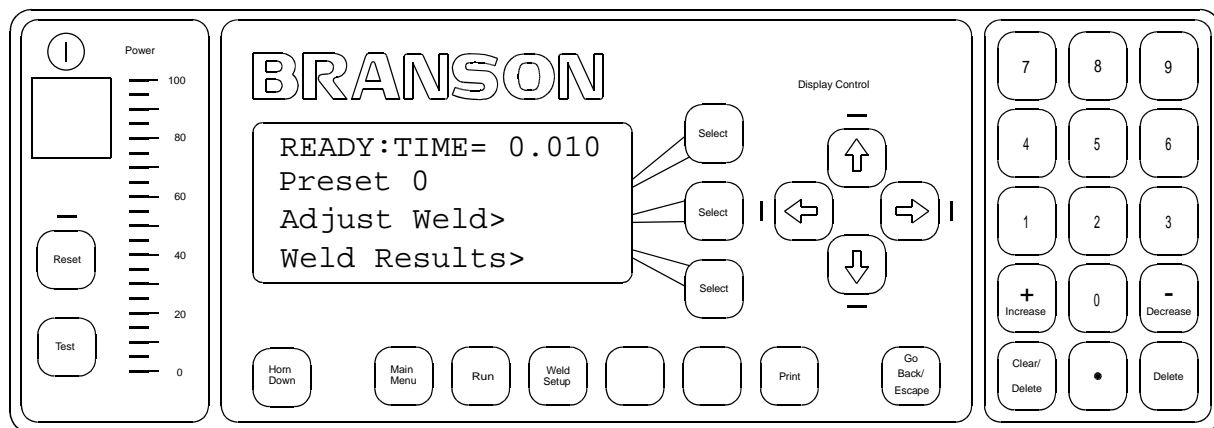

4.11 Still Need Help?

Branson is pleased that you chose our product and we are here for you! If you need parts or technical assistance with your 2000X-series system, call your local Branson representative or contact Branson customer service by calling the appropriate department as indicated in [Table 1.2 Branson Contacts](#), in Section [1.5.3 Departments to Contact](#).

Chapter 5: Technical Specifications

5.1 Technical Specifications - - - - - 5-1
 5.1.1 Requirement Specifications - - - - - 5-1
 5.1.2 Performance Specifications - - - - - 5-2
 5.2 Physical Description - - - - - 5-2
 5.2.1 Standard Items - - - - - 5-3

5.1 Technical Specifications

5.1.1 Requirement Specifications

The 2000ao Actuator requires compressed air. The factory air source must be “clean (5 micron) and dry,” that is, does not include moisture or lubricants. The Actuator requires 70 psi minimum pressure for operation and cooling, and can require up to 100 psig maximum, depending on the application. The following table lists environmental specifications for the ultrasonic welder.

Table 5.1 *Environmental Specifications*

Environmental Concern	Acceptable Range
Humidity	30% to 95% non-condensing
Ambient Temperature	+5°C to +50°C (+41°F to +122°F)
Storage/Shipping Temperature	-25°C/-13°F to +55°C/+131°F (+70°C/+158°F for 24 hours)

All electrical input power connections are to the Power Supply.

5.1.2 Performance Specifications

The following tables detail some of the performance specifications associated with the 2000aed Actuator.

Table 5.2 *Max. welding force, dynamic trigger force, dynamic follow-through*

Cylinder Size	Max. clamp force at 100 psig/690 kPa and 4"stroke	Dynamic triggering range	Dynamic follow-through range	Stroke length
1.5"	130 lbs / 578 N	5-159 lbf / 22-707 N	15-180 lbf / 67-800 N	4" / 101.6 mm
2.0"	270 lbs / 1.2 kN	15-180 lbf / 67-800 N	15-180 lbf / 67-800 N	4" / 101.6 mm
2.5"	440 lbs / 1.96 kN	15-180 lbf / 67-800 N	15-180 lbf / 67-800 N	4" / 101.6 mm
3.0"	640 lbs / 2.84 kN	15-180 lbf / 67-800 N	15-180 lbf / 67-800 N	4" / 101.6 mm
3.25"	770 lbs / 3.42 kN	15-180 lbf / 67-800 N	15-180 lbf / 67-800 N	4" / 101.6 mm

Table 5.3 *Maximum Traverse Speed (Application dependant)*

Down and Return Speed	Up to 7 inch/ 177.8 mm per sec. max at 3.5-inch / 88.9 mm stroke, 90 psi (all cylinder sizes)
-----------------------	---

Minimum Stroke: 1/8" / 3.2 mm

Maximum Stroke: 3-3/4" / 95.2 mm (for a 4" cylinder)

5.2 Physical Description

Refer to Chapter 4 for dimensional information.

5.2.1 Standard Items

Actuator Support

The actuator support is firmly clamped to the column. With the actuator support, you can adjust the height of actuator housing above the fixture position. You can set the height as needed for your application, or to facilitate servicing.

Actuator Base

Table 5.4 Description of Controls on Base

Name	Description
Start Switches	Activate the operating cycle through the actuator to the power supply when pressed simultaneously.
Emergency Stop Button	Interrupts the operating cycle (through the power supply) and causes the carriage to retract. Twist to reset.
Start Cable	Connects base to START connector on Actuator.

Slide Mechanism

The slide mechanism is based on eight sets of preloaded, permanently lubricated bearings, providing consistent, precise alignment of the horn, smooth linear motion, and long-term reliability.

Limit Switch

The optical Upper Limit Switch (ULS) signals the control circuits in the power supply that the carriage has returned to the top of its stroke (home) and is ready to start another operating cycle.

The power supply uses the ULS signal to perform various control functions, as in the following example:

- **Electronic Pretriggering:** A 2000-series Power Supply can use the ULS signal to activate ultrasonics before the horn contacts the workpiece. Pretriggering is used with large or difficult-to-start horns and in specialized applications.

Mechanical Stop

The mechanical stop limits the downward travel of the horn. To prevent equipment damage, adjust the stop so that the horn will not contact the fixture when no workpiece is in place. There is an indicator on the right side showing the position of the stop block. It is not intended for use in welding by distance.



CAUTION

Do not loosen the top hex-headed nut. Damage to the mechanical stop can result.



NOTE

Turning clockwise will increase the stroke length; turning counter-clockwise will shorten the stroke length. Adjustment is approximately 0.04-inch (1 mm) per rotation.

Pneumatic System

The pneumatic system is contained within the actuator and the remote pneumatics box. Refer to figure 5.1.

The system consists of:

1. a primary solenoid valve,
2. a cooling solenoid valve,
3. an air cylinder,
4. a pressure regulator,
5. an air-pressure gauge.
6. and a down speed flow control valve

The horn's rate of descent (downspeed) is adjusted at the front of the rp box using the Downspeed control knob. The rate of ascent is fixed.

2000X ao Actuator Chapter 5: Technical Specifications Instruction ManualPhysical Description

Figure 5.1 2000 Actuator Pneumatic Schematic

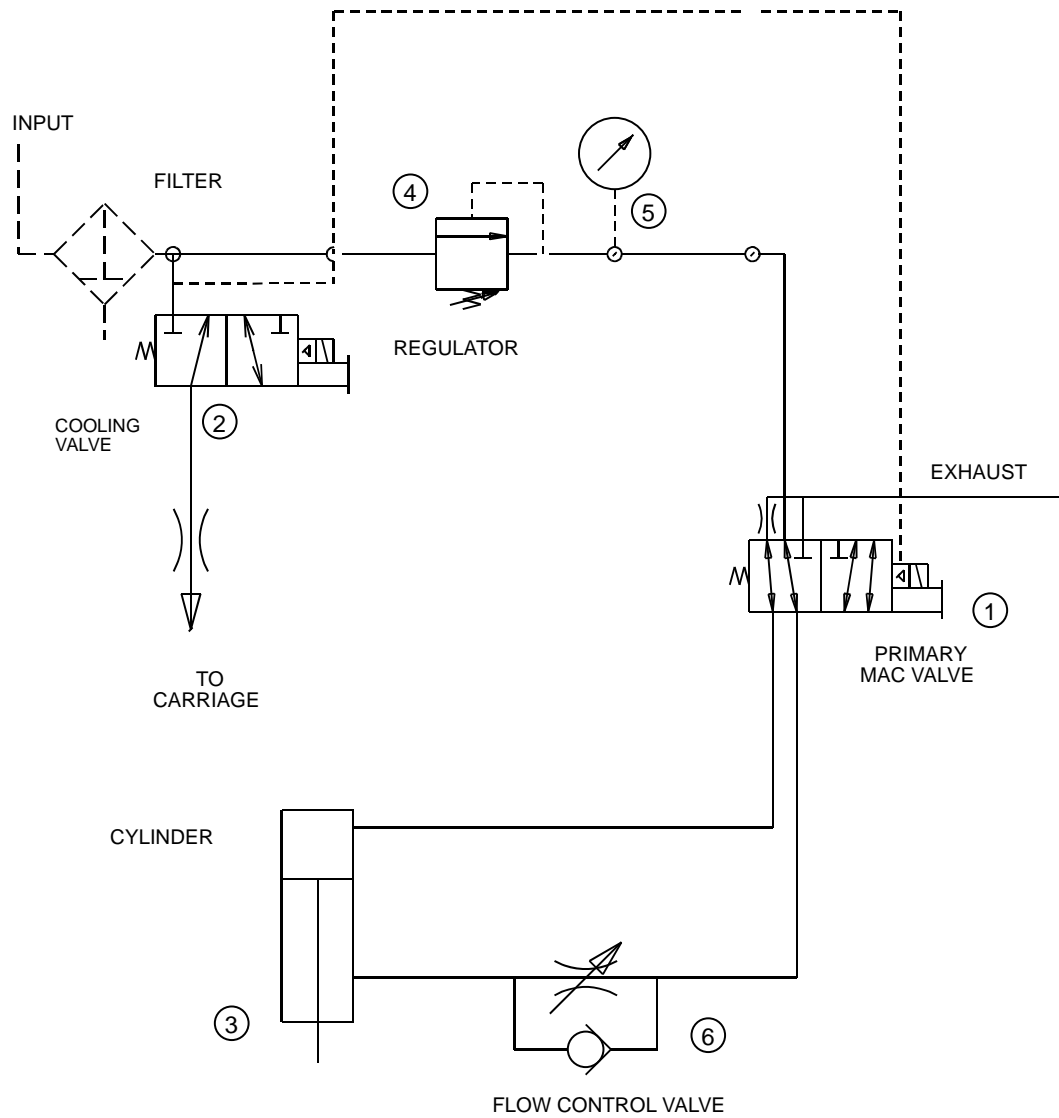

Chapter 6: Operation

- 6.1 Actuator Controls** - - - - - 6-1
- 6.2 Initial Actuator Settings** - - - - - 6-2
 - 6.2.1 Regulated Air Pressure and Air Pressure Gauge - - - - - 6-2
 - 6.2.2 Factory Air Source - - - - - 6-3
 - 6.2.3 Downspeed Control - - - - - 6-3
 - 6.2.4 Dynamic Trigger - - - - - 6-3
 - 6.2.5 Actuator Alignment and Height (Horn travel) - - - - - 6-4
 - 6.2.6 Mechanical Stop - - - - - 6-4
 - 6.2.7 Emergency Stop - - - - - 6-5
- 6.3 Operating the Actuator** - - - - - 6-5

6.1 Actuator Controls

This section describes how to operate a weld cycle using the 2000X ao Actuator. For more detailed information on making and altering settings, refer to your 2000X-series Power Supply manual.



WARNING

When setting up and operating the Actuator, observe the following precautions:

Keep hands away from under the horn. Down force (pressure) and ultrasonic vibrations can cause injury.

Plastic parts can vibrate within the audible frequency range when welded. If this occurs, use hearing protectors to prevent possible injury. Do not allow the ultrasonically activated horn to touch a metal base or a metal fixture.

The 2000X ao Actuator is controlled by the Power Supply. The Actuator sends operating cycle data (such as velocity and force), status information, and alarm information to the Power Supply. The Power Supply sends operating parameters to the Actuator, determining how and when weld cycles are initiated and terminated. The Actuator passes distance, force, and pressure information continuously to the Power Supply while in Setup mode. Refer to your 2000X-Series Power Supply manual for tuning, testing, setup, and operating instructions.



WARNING

When using larger horns, avoid situations where fingers could be pinched between the horn and the fixture. Contact Branson for information on an optional guard.

6.2 Initial Actuator Settings

The Actuator is controlled by the Power Supply, however there are several functions that are part of the Actuator. These include:

- Factory Air Source
- Regulated Air Pressure and Air Pressure Gauge (located on the rp)
- Downspeed Control (located on the rp)
- Mechanical Stop
- Actuator Position and Height above fixture (Horn travel)
- Emergency Stop (on Base, and provided as a User I/O signal for automation)

Each of these will affect the operation of the Actuator.

6.2.1 Regulated Air Pressure and Air Pressure Gauge

When factory air is present, it is delivered to the regulator, located on the rp box. The regulator knob is a push-to-lock knob to prevent undesired changes in your air pressure settings.



CAUTION

When factory air is removed from the system, or the dump valve is activated, the Actuator may “settle” to a lower position, since it is held up by the constant air pressure. Be sure to keep your hands and fingers from under the Horn or other pinch points, and use a block of wood or other soft material to block the Horn up to prevent damage to the tooling.

Initially, set the Regulator Knob to a counter-clockwise position, which is a low pressure setting. In the event something is incorrectly connected, a low air pressure setting will reduce any sudden movement. A typical initial setting is approximately 20-25 psi for a new or unproven setup.



CAUTION

Permanent damage to the system and possible injury can result if the Actuator is supplied with factory air above the maximum gauge reading of 100 psig (690kPa). Set the pressure regulator to zero before connecting or disconnecting the factory air supply.

6.2.2 Factory Air Source

Factory air must be turned on, supplying the actuator's air pressure regulator with air pressure. If factory air is too low (below 35 psi maintained) the actuator will not weld or operate reliably. Factory air is also used to provide cooling air to the converter.

Factory air input may affect weld results for applications requiring more weld pressure buildup.



NOTE

Factory Air pressure must be greater than the maximum system requirements. The compressed air system must have sufficient capacity to serve all of the systems connected to it. The use of an accumulator may be required to provide continuous air flow.

6.2.3 Downspeed Control

The Downspeed Control regulates the horn velocity. Downspeed has a significant effect on the force buildup on the workpiece, and hence the quality of the weld. If the Downspeed control is closed, the actuator will not extend



NOTE

Be sure to set the down speed control to a slow setting, between 5 and 15, for an initial setup. The downspeed control knob has a set-screw locking mechanism that can be used, if desired.

6.2.4 Dynamic Trigger

The Dynamic Trigger should initially be set between 1 and 5.

6.2.5 Actuator Alignment and Height (Horn travel)

The horn carriage will travel up and down on the actuator's slides. The actuator can also be adjusted up or down on the column. The distance between the fixture and horn should allow easy and ready access and removal of your parts.

- Minimum stroke cannot be less than 1/8".
- Maximum stroke cannot exceed 3-3/4" before part contact to allow for the operation of the dynamic flow through mechanism.

Consistent weld results are best measured when the horn travel is more than 1/4 inch, because a shorter distance can be affected by other components of the welding system and a suitable build-up of pressure on the parts.

6.2.6 Mechanical Stop

The Mechanical Stop affects the amount of downward travel the Actuator is allowed to have, up to the full stroke length of the unit. The multi-turn knurled knob to the right of the Stack, on the bottom of the Actuator, is the Mechanical Stop adjustment. The Mechanical Stop has an indicator on the right side of the Actuator, showing a scale of an arbitrary unit of measure.

The Mechanical Stop is designed to stop the Horn from contacting your Fixture in the event your part is missing. It is not a precision measuring device, and it is usually *not recommended* that this be used as a 'collapse' or other distance weld limiting device. The "missing part" function can also be used to control critical horn to fixture distances.

Initially, set the mechanical stop to allow at least 1/4 inch of Horn travel, but any distance up to the full stroke length is suitable.

To adjust the Mechanical Stop:

Step:	Action:
1	Activate the manual dump valve and manually lower the carriage until the horn is just above the fixture.
2	If the horn does not reach the fixture and has not travelled 4 inches (100 mm), loosen the lock ring fully and turn the mechanical stop-adjusting knob clockwise until the carriage reaches the desired position. If the horn reaches the desired position before contacting the stop, turn the adjusting knob counter-clockwise until the stop contacts the carriage.
3	Check the height of the horn and make any necessary adjustments to the stop.

4	When you have reached the setting you want, tighten the lock ring. The lock ring will prevent the mechanical stop adjustment from vibrating loose during operation.
5	Place a part in the fixture, reset the air pressure, and perform a test weld.
6	Check that full force develops between the horn and the part. If not, readjust the mechanical stop.



NOTE

Due to Dynamic Follow Through, do not weld in the last 1/4" of stroke.

6.2.7 Emergency Stop

The Emergency Stop is a user control that will prevent the actuator from running, and will also immediately terminate a weld cycle and cause the Horn to retract. It does not remove power from the system. The controls can be configured to provide a beep sound when the emergency stop is engaged. The front panel display of the power supply will indicate that the system is in emergency stop mode when it is. Twist the emergency stop button to reset the system.

6.3 Operating the Actuator

For detailed information about 2000X ao Actuator controls, refer to *Section 2.4: Controls and Indicators*.

To operate the X ao actuator:

Step:	Action:
1	If your application has been analyzed in the Branson Applications Laboratory, consult the Branson Lab Report for appropriate settings or check your 2000X Power Supply manual.
2	Properly adjust the mechanical stop so that the horn does not make contact with your fixture. (Refer to 6.2.6 'Mechanical Stop' on page4 for more information on this adjustment.)
3	If the Actuator is mounted on a Base, make sure that the Emergency Stop button is not pushed in. If not using the Branson Base, verify that the Emergency Stop signal source is not in the Emergency Stop mode.

Step:	Action:
4	With a part in place, depress and hold both start switches simultaneously, or activate the start mechanism.
5	The horn advances and contacts the part.
6	Force develops between the horn and the part, activating the load cell.
7	Ultrasonic vibrations are activated. The power bar graph on the power supply indicates loading (usually in the 25% to 100% range). The start switches can now be released.
8	Ultrasonics stop and the horn continues to clamp the part for the hold time you selected.
9	After the completion of the hold cycle, the horn retracts automatically and you can remove the part from the fixture.
10	Weld a few parts using the initial parameters and check for the desired properties.

If you do not obtain optimal results initially, based on the quality of the weld obtained and the loading meter reading, you can alter settings to achieve satisfactory results. Change one setting at a time until a weld is produced in minimum time with maximum strength.

Chapter 7: Maintenance

7.1 Calibration - - - - - 7-1

7.2 Periodic and Preventive Maintenance - - - - - 7-1

7.2.1 Periodically Clean the Equipment - - - - - 7-1

7.2.2 Recondition the Stack (converter, booster, and horn) - - - - 7-2

7.2.3 Routine Component Replacement - - - - - 7-4

7.3 Parts Lists- - - - - - 7-5

7.1 Calibration

This product does not require scheduled calibration. However, if you are operating under requirements that mandate periodic calibration, for example, the FDA's Good Manufacturing Practices, contact your Branson representative for additional information.

7.2 Periodic and Preventive Maintenance

The following preventive measures will help ensure long term operation of your Branson 2000X Series Actuators.

7.2.1 Periodically Clean the Equipment

Periodically disconnect the unit from power, remove the cover and vacuum out any accumulated dust and debris. Remove material adhering to the circuit boards, cooling intake vents and exhaust ports. Periodically disconnect the airline from the air supply, open the air filter and clean the element and bowl with mild soap and water. External covers may be cleaned with a damp sponge or cloth using a solution of mild soap and water. Do not allow cleaning solution to enter the unit. Exposed steel surfaces, such as handles, hardware and the main column may require a very light film of oil, such as WD-40, to prevent rust in areas of high humidity.

7.2.2 Recondition the Stack (converter, booster, and horn)

Stack components function with greatest efficiency when the mating interface surfaces are in proper condition. For 20kHz and 30kHz products, a Branson Mylar washer should be installed between the horn and the booster, and booster and converter. Replace the washer if torn or perforated. We recommend that stacks using Mylar washers be inspected every three months.

Stacks used with silicone grease, as with certain 20 kHz installations and with all 40 kHz products, should be periodically reconditioned to eliminate fretting corrosion. We recommend that a stack using silicone grease be inspected every two weeks for corrosion. The inspection interval can then be adjusted longer or shorter as required, when experience is gained for specific stacks. See the Branson instruction manuals for correct stack interface reconditioning procedures.



NOTE

The operating efficiency of the equipment will be greatly affected if the mating interfaces of the converter, booster, and horn are not flat, make poor contact with each other, or become corroded. A poor contact condition wastes power and makes tuning difficult. It may also affect the noise level and damage the converter.

To recondition the interfaces:

1. Remove the stack from the actuator.
2. Disassemble the converter, booster, and horn stack. Observe the following rules:

In the event that you must disassemble a Stack, always use the correct spanner wrench and a suitable soft-faced vise to remove a horn or booster, and reverse the procedures described earlier in this Section.



CAUTION

NEVER attempt to remove a horn or booster by holding the converter housing or booster clamp ring in a vise.



NOTE

Use a soft-jawed vise (brass or aluminum) to remove square or rectangular horns, or horns otherwise unremovable, by reversing the procedure detailed in [Section 4.8 Assemble the Acoustic Stack, beginning on page 4-31](#).

3. Wipe the interfaces with a clean cloth or paper towel.
4. Examine all interfaces. If any interface is corroded or shows a dark, hard deposit, it should be reconditioned.
5. If the interfaces appear to be in good condition, go to step 13.

6. If necessary, remove the coupling studs.
7. Tape a clean sheet of #400 grit (or finer) emery cloth to a clean, smooth flat surface. A piece of glass is suitable.
8. Hold the part to be conditioned at its lower end and carefully stroke it in one direction across the emery cloth. Do not press down. the weight of the component provides enough pressure.
9. Perform a second stroke. Rotate the part 1/3 around and stroke it twice across the cloth.



NOTE

Use no more than two strokes in one position. Use the same number of strokes at each location.

10. Turn the part the remaining 1/3 and repeat.
11. Re-examine the interface and repeat steps 8, 9, and 10 until the surface appears clean and smooth. This should not take more than 2 or 3 complete rotations of the part being reconditioned.
12. Clean the threaded hole, using a clean cloth or paper towel.
13. Replace the stud with a new one if removed. Torque the 3/8-24 studs to 290 inch pounds (32.77 Nm). Torque 1/2-20 studs to 450 inch pounds (50.84 Nm). Torque M8x1-1/4 studs to 70 inch pounds (7.9 Nm).



NOTE

The use of a Branson torque wrench or the equivalent is recommended. P/N 101-063-617 for 20kHz systems and 101-063-618 for 40kHz systems.



CAUTION

Failure to follow torque specifications may cause the stud to loosen or break, and the system to overload. The use of a Branson torque wrench or equivalent is required.

14. Reassemble the stack and install it in the actuator, using the procedures in Section [4.8 Assemble the Acoustic Stack, beginning on page 4-31](#) of this manual.

7.2.3 Routine Component Replacement

The lifetime of certain parts is based on the number of cycles the unit has completed, or on hours of operation. [Table 7.1](#) lists the average number of hours or cycles one should use in determining when components should be replaced. Ambient operating temperature also affects lifetime. Higher temperatures reduce the number of cycles and hours before replacement is suggested.

The charts below are for equipment operating at a temperature of 72 to 75°F (22 - 24° C).

The lifetime of system pneumatic components is influenced by the quality of the compressed air provided. All Branson systems require clean, dry, (normal) factory compressed air. When oil or moisture is present in the compressed air, the lifetime of the pneumatic components will be reduced. This table lists pneumatic parts with an average factory compressed air condition.

Table 7.1 Component Replacements Based on Cycles Run

At 10 Million Cycles	Air Cylinder
At 20 Million Cycles	Base Palm Buttons
At 40 Million Cycles	Solenoid Valves
	Pressure Regulator
	Air Filter
	Cooling Valve
	Linear Bearing (2" stroke or greater)

For Reference Purposes:

- 1) A system operating at 60 welds per minute, 8 hours per day, 5 days per week, 50 weeks per year completes approximately 7.2 million cycles in 2000 hours.
- 2) The same system at 24 hours per day, 5 days per week, in 50 weeks completes 21.6 million cycles in 6000 hours.
- 3) 24 hours per day, 365 days per year produces 31.5 million cycles in 8760 hours.

Please note that parts replaced during preventive maintenance constitute normal wear and tear. They are not covered by warranty.

7.3 Parts Lists

The following tables lists the available Accessories (Table 7.2) and Parts (Table 7.3) for the 2000ao Actuator:

Table 7.2 *Accessories List for ao Actuator*

Description	EDP Number
ao Actuator with 1.5-inch diameter cylinder	101-134-270
ao Actuator with 2.0-inch diameter cylinder	101-134-271
ao Actuator with 2.5-inch diameter cylinder	101-134-272
aoActuator with 3.0-inch diameter cylinder	101-134-274
aol Actuator with 2.5-inch diameter cylinder	101-134-273
aol Actuator with 3.0-inch diameter cylinder	101-134-275
RP Package (requires PLA and J924 cable)	101-246-1350
RP Actuator mount kit (mounts RP to left or right side of actuator)	101-063-547
Kit Base Guard (for large horns)	101-063-550
Remote Pneumatics Box (rp)	101-134-108
Remote Pneumatics Low Force Box for 1.5" and 2.0"(rplf)	101-246-1351
AE/AO Dump Valve	100-246-952
Inch Leveling Plate	101-063-358
Metric Ball Bolt (adapts 2000X base to leveling plates)	100-298-085
Metric Leveling Plate	101-063-444
CJ20 Acorn (in actuator)	101-135-059
CA30 Acorn	101-134-114
30kHz Booster Adapter Ring (for use with CA30)	100-087-283

Table 7.2 Accessories List for ao Actuator (Continued)

Description	EDP Number
4TJ Acorn (in actuator)	101-135-041
40 kHz Adapter Sleeve Assy (same as 900)	100-246-612
Stand-Base, 4" OD, 3.5" ID col, support	100-246-1314
Stand-Hub, 4" ID, col support	100-246-1344
Base, ergo - 4" metric, black	100-246-1313
Hub, 2000X for 4" column	101-063-583
Support 4" black	100-246-1311
Column 4', 4" OD x 1/4" wall	100-028-021
Column 4', 4" OD x 1/2" wall (option)	100-028-011
Column 6', 4" OD x 1/2" wall (option)	100-028-012
Sleeve, 1/4" wall column	100-094-159
Sleeve, 1/2" wall column	100-094-102
900 Series Boosters 1/2-20 Input; 1/2-20 Output	
Black (Ti), Ratio 1:2.5	101-149-059
Silver (Ti), Ratio 1:2	101-149-058
Gold (Ti), Ratio 1:1.5	101-149-057
Green (Ti), Ratio 1:1	101-149-056
Purple (Ti), Ratio 1:0.6	101-149-060
Silver (Al), Ratio 1:2	101-149-053
Gold (Al), Ratio 1:1.5	101-149-052
Green (Al), Ratio 1:1	101-149-051
Purple (Al), Ratio 1:0.6	101-149-055
Solid Mount Boosters - 20kHz - 1/2-20 Input, 1/2-20 Output	
Black (Ti), Ratio 1:2.5	101-149-099
Silver (Ti), Ratio 2:1	101-149-098
Gold (Ti), Ratio 1:1.5	101-149-097

Table 7.2 Accessories List for ao Actuator (Continued)

Description	EDP Number
Green (Ti), Ratio 1:1	101-149-096
Purple (Ti), Ratio 1:0.6	101-149-095
Boosters - 30kHz (for use with CA-30 converter)	
Black (Ti), Ratio 1:2.5	101-149-120
Silver (Ti), Ratio 1:2.0	101-149-121
Gold (Ti), Ratio 1:1.5	101-149-122
Green (Ti), Ratio 1:1	101-149-123
Purple (Ti), Ratio 1:0.6	101-149-124
Boosters - 40kHz (Same as XL: 8 mm)	
Black (Ti), Ratio 1:2.5	101-149-084
Silver (Ti), Ratio 1:2.0	101-149-083
Gold (Ti), Ratio 1:1.5	101-149-086
Green (Ti), Ratio 1:1	101-149-085
Black (Al), Ratio 1:2.5	101-149-082
Silver (Al), Ratio 1:2.0	101-149-081
Gold (Al), Ratio 1:1.5	101-149-080
Green (Al), Ratio 1:1	101-149-079
Purple (Al), Ratio 1:0.6	101-149-087
Solid Mount Boosters - 40kHz (Same as XL: 8mm)	
Black (Ti), Ratio 1:2.5	109-041-174
Silver (Ti), Ratio 1:2.0	109-041-175
Gold (Ti), Ratio 1:1.5	109-041-176
Green (Ti), Ratio 1:1.0	109-041-177
Purple (Ti), Ratio 1:0.6	109-041-178

Table 7.3 Spare Parts List for the aoActuator

RF Harness Assembly	100-246-922
TRS Harness Assembly (only with dynamic trigger)	100-246-1283
RF Harness, aol/aodl	100-246-1003
RF Contact Block Assembly	100-246-909
Dynamic Trigger Assembly	100-246-697
Cooling Valve Assembly	100-246-896
Solenoid Valve	100-246-901
Downspeed Control Assembly (Flow Control 2.5" and 3.0")	100-246-902
Low Force Flow Control Assembly (1.5" and 2.0" cyl. Dia.)	100-246-1092
2000ao Distribution Board	100-242-716R
ULS Cable Assembly	100-241-181
Power Light Harness Assembly	100-246-924
Carriage 2000X Series	100-018-039
Assy Cylinder AE/AO - 1.5" Diameter	100-246-600
Assy Cylinder AE/AO - 2.0" Diameter	100-246-778
Assy Cylinder AE/AO - 2.5" Diameter	100-246-562
Assy Cylinder AE/AO - 3.0" Diameter	100-246-559
Assy Cylinder AE/AO - 3.25" Diameter	100-246-935
Assy Cylinder AOL/AODL - 2.5" Diameter	100-246-926
Assy Cylinder AOL/AODL - 3.0" Diameter	100-246-934
Door (Plastic)	100-037-038
Door (Metal)	100-037-035
Cover AO/AOD Actuator	100-032-461
Cover, aol/aodl	100-032-462
MECHANICAL STOPS	
Rod Mech Stop	100-089-066
Block Mech Stop	100-006-197
Insulator Teflon Pad	100-062-105
Spring, Compression	200-095-138
Washer, Flat #8	200-114-013
Washer Intl M6	200-114-114
Nut Mtg Mech Stop	100-073-187
Nut Lock Mech Stop	100-073-188
Knob Mech Stop	100-064-054
Bumper Return	100-013-018

Table 7.3 *Spare Parts List for the aoActuator*

Scr Set M6 x 6	200-298-102
Spring Carriage Ext	100-095-139
Assy Regulator	100-246-553
Assy Gauge	100-246-554
Assy RF Connector	100-246-932
ULS Switch Optical	200-099-190

Table 7.4 *Suggested Spares*

Assembly	EDP #	1 - 4 Units	6 - 12 Units	14 + Units
RF Harness	100-246-922	0	1	2
RF Harness, aol/aodl	100-246-1003	0	1	2
RF Connector	100-246-932	0	0	1
Slide Bearing	200-003-080	0	0	0
Mech. Stop Rod	100-089-066	0	0	0
Block	100-006-197	0	0	0
Insulator	100-062-105	0	0	0
Spring	200-095-138	0	0	0
Mounting Nut	100-073-187	0	0	0
Lock Nut	100-073-188	0	0	0
Knob	100-064-054	0	0	0
Knob Set Screw	200-298-102	0	0	0
Pin	200-078-146	0	0	0
Extension Spring	100-095-139	0	0	0
Eyebolt	200-298-027	0	0	0
Carriage	100-018-039	0	0	0
Carriage Door	100-037-035	0	0	0
Door Screw	100-298-242	0	0	2
Contact Block	100-246-909	1	1	2
Ground Spring	100-095-024	0	0	1
2000XAO Distribution Board	100-242-716R	0	0	1
ULS Switch	200-099-190	0	1	2

Air Cylinder, 3.0"	100-246-559	0	1	1
Assembly	EDP #	1 - 4 Units	6 - 12 Units	14 + Units
Air Cylinder, 2.0"	100-246-562	0	1	1
Solenoid Valve	100-246-901	1	1	2
Dynamic Trigger	100-246-697	0	0	1
Cooling Valve	100-246-896	1	2	4
Power Light	100-246-924	0	1	1
ULS Cable	100-241-181	0	1	1
D Shell Kit	200-063-195	0	1	1
Start Switch	200-099-236	0	2	4
E-Stop Switch	200-099-237	0	1	2



NOTE

When ordering spare cylinders note the cylinder diameter which is found on the actuator door cover.

Index

A

About Installation	4-2
Actuator	
Base	5-3
Slide Mechanism	5-3
Support	5-3
Actuator (Alone)	3-3
Actuator Controls	6-1
Actuator Settings, Initial	6-2
Actuator Alignment and Height (Horn travel)	6-4
Downspeed Control	6-3
Emergency Stop	6-5
Factory Air Source	6-3
Mechanical Stop	6-4
Regulated Air Pressure and Air Pressure Gauge	6-2
Air Cylinder Consumption	4-11
Air Filter	4-15
Air filter	4-15
ao Actuator	
Dimensional Drawing	4-13
Assemble the Acoustic Stack	
For a 20 kHz System	4-31
For a 30 kHz System	4-32
For a 40 kHz System	4-32
Assembling the 20kHz Acoustic Stack	4-33

B

Block Wiring Diagram	4-14
----------------------------	------

C

Cables	4-8
Calibration	7-1
Connecting Tip to Horn	4-34
Controls	2-7

D

Data Receive	4-24
Data Send	4-24
DB-9 format connector	4-24
Disclaimer of Warranty	1-6
Dynamic Trigger Mechanism.....	2-9
Dynamic Triggering and Follow-Through	2-4

E

Electrical Input Power Ratings	4-10
Emergency Stop Button	
reset	4-29
Emergency Stop Control	4-29
Environmental Specifications	3-1, 4-9, 5-1
Ergonomic Base	2-1

F

Factory Air	4-15
Factory Air Supply	
clean Specs	4-15
maximum pressure.....	4-15

G

Glossary of Terms	2-10
Ground Detect	4-21

H

Handling and Unpacking	4-2
Host Computer	4-24
Humidity	5-1

I

In-line air filter 4-15
Input Power (Main) 4-21
Input Power Plug 4-27
Installation 4-1
Installation Requirements 4-9
Installation Steps 4-16
Installing the Stack in the Actuator
 20 kHz Stacks 4-35
Interconnect between Power Supply and Actuator 4-21

L

Limit Switch 5-3

M

Maintenance 7-1
 Periodic and Preventive 7-1
Mechanical Stop 5-3
Module Options DIP Switch 4-28
Mounting the Fixture on the Branson Base 4-37

O

Operating the Actuator 6-5
Operation 6-1
Output Power (RF Cable) 4-21

P

Parallel Printer Connector	4-24
Parts Lists.....	7-5
Accessories List	7-5
Spare Parts	7-8
Periodic and Preventive Maintenance	
Periodically Clean the Equipment	7-1
Recondition the Stack (converter, booster, and horn).....	7-2
Routine Component Replacement	7-4
Pneumatic Connections to Actuator	4-15
Pneumatic System	5-4
Pneumatic Tubing and Connectors	4-15
Power Supply Dimensional Drawing	4-12
Pressure Indicator	2-7
PVC Materials	1-6

R

Rack Mount Installation	4-29
Receiving.....	3-2
Requirement Specifications.....	5-1
Returning Equipment.....	3-3
RS-232	4-24
RS-232c	4-24

S

Safety	
Guards.....	4-29
PVC Materials	1-6
Serial (RS-232) Port	4-24
Serial port	4-24
Setup	4-1
Shipping and Handling	3-1
Shock	3-1
Slide Mechanism	5-3
Special Cable requirements	4-20
Stack	2-8, 2-9
stack	2-7
Stack Assembly Torque Values	4-34
Stand	
Actuator on Base.....	3-3
Actuator on Hub-Mounted Column.....	3-3
Stand, Actuator on Base	3-3
Start Switch Connection (Automation)	4-23
Still Need Help?.....	4-39
Stop button	4-29

T

Take Inventory of Small Parts	4-7
Technical Specifications.....	5-1
Temperature	
Ambient	5-1
Shipping and Storage.....	3-1, 5-1
Testing the Installation	4-38
Tip to Horn Torque Specifications	4-34

U

Unpack the Stand or Actuator	4-3
Unpacking Actuator Assemblies.....	3-3
Upper Limit Switch	5-3
User I/O Cable Pin Assignments.....	4-25
User I/O DIP Switch (SW1)	4-28
User I/O Input and Output Function Selection.....	4-27
User I/O Interface	4-24

V

Vibration 3-1

W

Warranty 1-6
Welding Systems..... 2-8
 Booster 2-8
 Converter..... 2-8
 Horn..... 2-9
 Load Cell and Dynamic Follow Through 2-9
 Power Supply 2-8
 Ultrasonics Plastics Welding 2-8