

BRANSON



Spin Welder Model SW300

Spin Welder Model SW300

The Branson Model SW300 is a precision servo-driven spin welding system capable of welding circular joint interface parts with accurate control and highly consistent results. The SW300 can be configured to manual, semi-automated, or fully-automated manufacturing environments.



Key Features and Benefits

- Motor (5.1 kW/6.8 hp) and drive combination capable of 30 Nm of peak torque at 240V AC, 3 Ø input power.
- Settable servo motor speed (250–3500 rpm @240V AC input power).
- Servo motor accuracy of ± 0.1 degree.
- Mechanical stop indicator on the outside of the actuator.
- 6" color touchscreen operator interface.
- Intuitive operator interface allows easy movement between screens.
- Storage of up to 30 recipes (presets).
- Weld data information for up to 15 previous cycles available on operator interface.
- Counterclockwise or clockwise spin direction.
- User selectable units (SAE or metric).
- User selectable languages (English, German, Italian, Czech, Polish, French, Spanish).
- User configurable I/O (four of each).
- Two levels of password protection –
 - Operator: run parts and view data;
 - Supervisor: access to all screens.

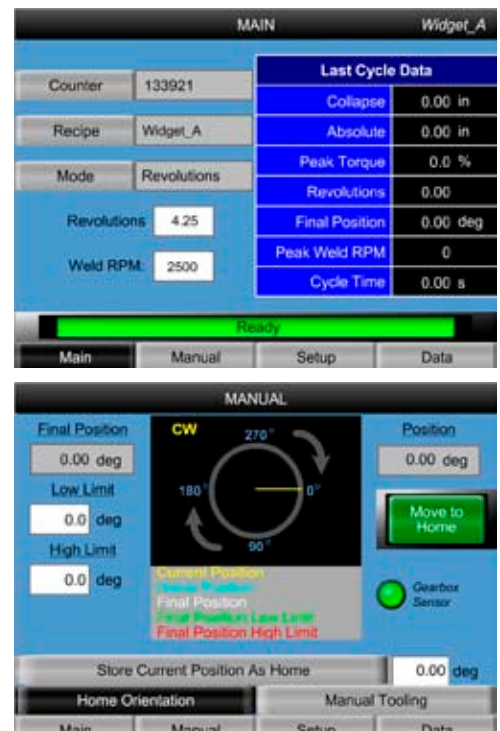

Operator Interface Screens.

Key Features and Benefits (continued)

- Linear encoder for ease of setup. Allows for collapse and absolute height modes.
 - Absolute height.
 - Part clamp position
 - Collapse (meltdown)
 - Final orientation/position
 - Peak torque
 - Revolutions
 - Weld speed (rpm)
- Higher speed motor setup, 250-4800 rpm at 480V AC, 3 Ø.
- RS232 comma separated data output to PC
 - Cycle count, recipe name, mode, spin direction, pre-weld speed, peak weld speed, number of revolutions, final orientation position, peak torque, collapse distance, absolute position, trigger mode, trigger setpoint, dwell time, hold time, cycle time, weld time.
- Automation alarm cable connection (15 pin)
 - Allows for spin welder to be connected to automation
 - Allows for automation to select up to 15 recipes
 - Provides reset of alarms remotely input to the SW300
 - Provides a 24V DC and 0V DC pin from the SW300
 - Provides ready to home, ready to index, ready to weld, weld active, and alarm active signals from the SW300
- Three modes of operation:
 - Revolutions (orienting)
 - Collapse
 - Absolute position

Recommended Spin Weld Tool Mounting Dimensions

Options

- 6-foot column.
- Pneumatic package for vacuum in fixture (also can be used for part sensing in the fixture).
- Pneumatic package for slide/clamp in fixture (some tools require pneumatic clamps).
- Vacuum spindle assembly (includes pneumatic package for vacuum) for holding part in spinning tool prior to weld.
- Upgrade to 3:1 gear box (reduces speed to 50-1000 rpm).
- Upgrade to 5:1 gearbox (reduces speed to 50-750 rpm).
- Metric or SAE leveling plate.
- Upgrade to 7.87" (200 mm) stroke.
- Upgrade to 3.15" (80 mm) bore cylinder (allows for higher clamp force on part).
- Remote mounted operator interface.
- Actuator is available without palm-button base for vertical mounting in automation, or without column and base for horizontal/vertical mounting in automation.
- Input power up to 480V AC, 3 Ø.
- Can be incorporated into dial table systems (Branson Series 30 or 40, custom semi-automated or fully automated systems).

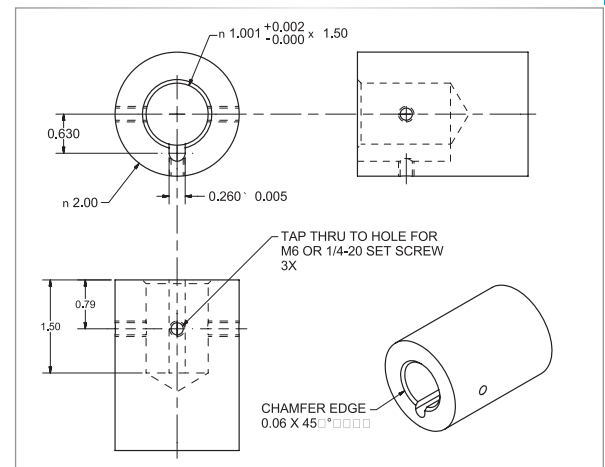

Spin Welding

Mechanical Specifications

Weight:	
Actuator and stand:	315 lbs. (143 kg)
Control box:	88 lbs. (40 kg)
Stroke length:	3.94" (100 mm)
Height adjustment:	27.4" (695 mm)
Throat (tooling centerline to column):	9.69" (246 mm)
Bottom of spindle to base distance:	5.0" to 32.4" (127 to 822 mm)
Maximum force applied to part:	225 lbs. (1.0 kN)
Pneumatic requirement:	Clean (5 micron), dry air, 100 psi max.; 1 CFM

Electrical Specifications

Power requirement:
240-480 V AC, 3 Ø, 20 amps, 50/60 Hz

Ordering Information

	Branson EDP No.
Model SW300	300-101-127

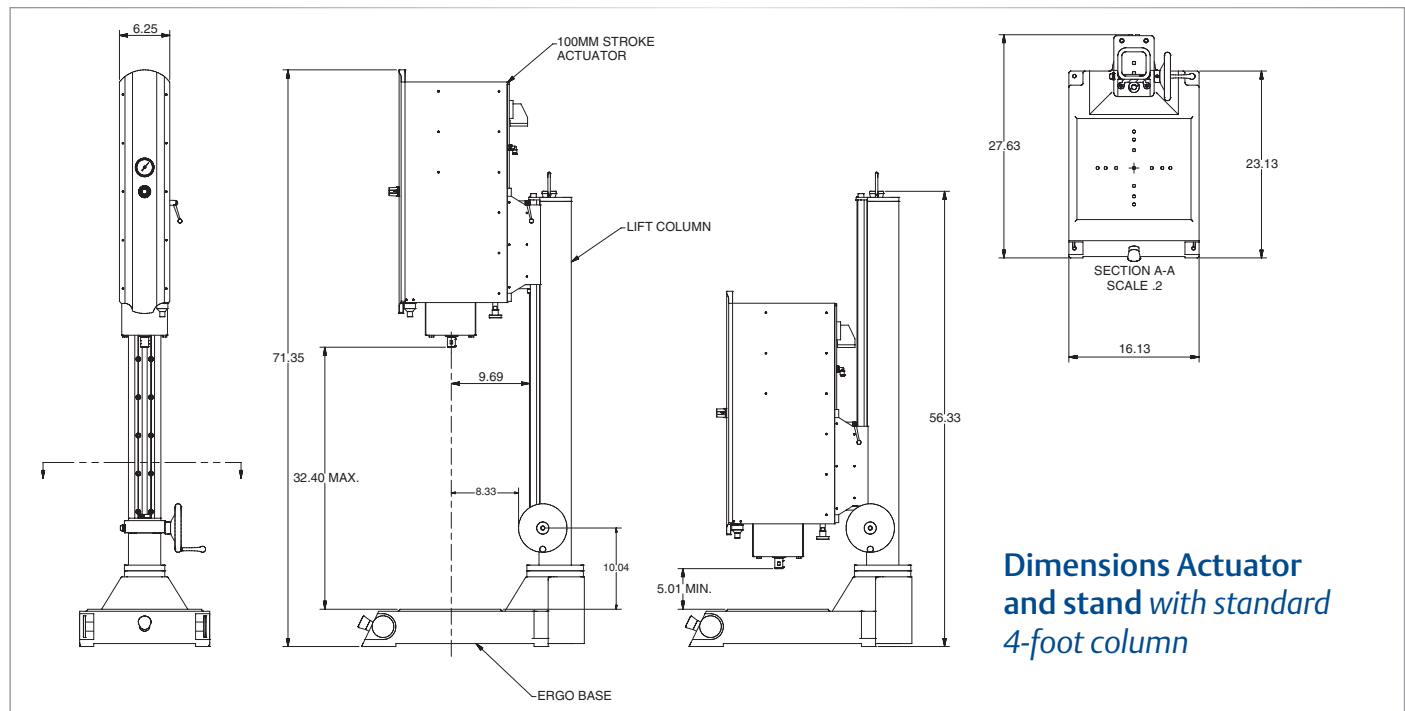

Dimensions Actuator and stand with standard 4-foot column

BRANSON

Branson Ultrasonics Corporation
41 Eagle Road, Danbury, CT 06813-1961
(203) 796-0400 • Fax: (203) 796-9838
www.bransonultrasonics.com
e-mail: info@bransonultrasonics.com

475 Quaker Meeting House Rd.,
Honeoye Falls, NY 14472
(585) 624-8000 • Fax: (585) 624-1262

All specifications subject to change without notice.

Note: All sales shall be subject to the Supplier's terms and conditions of sale as described in Branson's quotations and sales contracts.

Warranty: The SW300 Spin Welder is warranted to be free from defects two years for parts and one year for labor starting from date of shipment.