

Data Interface Gateway

User Manual

Branson Ultrasonics Corporation
120 Park Ridge Road
Brookfield, CT 06804
(203) 796-0400
<http://www.bransonultrasonics.com>

BRANSON

[This page intentionally left blank]

Manual Change Information

At Branson, we strive to maintain our position as the leader in ultrasonics plastics joining, metal welding, cleaning and related technologies by continually improving our products. These improvements are incorporated as soon as they are developed and thoroughly tested.

Information concerning any improvements will be added to the appropriate technical documentation at its next revision. Therefore, when requesting service assistance for specific units, note the revision information found on this document.

Copyright and Trademark Notice

Copyright © 2022 Branson Ultrasonics Corporation. All rights reserved. Contents of this publication may not be reproduced in any form without the written permission of Branson Ultrasonics Corporation.

[This page intentionally left blank]

Table of Contents

Chapter 1: Introduction

1.1	Introduction	8
1.2	Technical Specifications	9
1.3	DIG Kits	11
1.4	Network Configuration	12

Chapter 2: Machine Settings

2.1	GVX/GLX/GIX/GVH/GL	16
2.2	Ultrasonic Welders	18
2.3	2000Xc Ultrasonic Welder	19
2.4	2000Xdt/2000Xea Ultrasonic Welder	21
2.5	L20 Touchscreen Machine	22
2.6	L20 VersaGraphix Machine	25
2.7	Data Interface Gateway (DIG)	27

Appendix A: FBWF Manager (2000Xc)

A.1	File Based Write Filter (FBWF)	34
A.2	Disabling the FBWF Manager	35

Appendix B: Data Records

B.1	GVX/GLX/GIX/GVH/GL	38
B.2	2000Xc/2000X Series	53
B.3	L20 Touchscreen & L20 VersaGraphix	55

Appendix C: UaExpert Client

C.1	UaExpert Client Example	58
-----	-----------------------------------	----

Appendix D: RS232 to Ethernet Converter

D.1	RS232 to Ethernet Configuration	62
-----	---	----

Appendix E: Warranty

[This page intentionally left blank]

Chapter 1: Introduction

1.1	Introduction	8
1.2	Technical Specifications	9
1.3	DIG Kits	11
1.4	Network Configuration	12

1.1 Introduction

The Data Interface Gateway (DIG) is a communication controller with proprietary Branson equipment software embedded that securely connects Branson equipment to a user's network., e.g. MES or local production supervisory systems.

DIG provides machine data by an integrated OPC-UA server.

This document gives information for clients, who are accessing OPC-UA server in DIG.

1.1.1 DIG Kits

There are two Data Interface Gateway kits, depending on your Branson equipment. Most equipment is Ethernet capable and uses the Ethernet Gateway Kit. For legacy L20 Touchscreen and 2000X equipment, the RS232 Kit is required.

1.2 Technical Specifications

NOTICE	
	All specifications are subject to change without notice.

1.2.1 DIG Environmental Specifications

The Data Interface Gateway has the following environmental specifications:

Table 1.1 Environmental Specifications

Environmental Condition	Acceptable Range
Ambient Operating Temperature	+5°C to +40°C
	+41°F to +104°F
Storage / Shipping Temperature	-25°C to +55°C
	-13°F to +131°F
Operating Altitude	2000 m
	6561 ft

1.2.2 DIG Electrical Specifications

Table 1.2 DIG Electrical Specifications

Name	Description
Supply Voltage	18 VDC ... 30 VDC
Typical/Maximum Current	170 mA/400 mA @ 24 V
Power Consumption:	4.2 W - Max. 9 W



1.2.3 Module RS232 to Ethernet Electrical Specifications

Table 1.3 Module RS232 to Ethernet Electrical Specifications

Name	Description
Supply Voltage	4.75 VDC ... 7 VDC
Typical Current	150 mA @ 5 V

1.2.4 Power Configuration

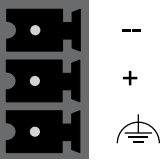
Table 1.4 Power Supply Connector

DC 24 V	DIG Label	Signal	Description
	--	GND	Ground (reference potential)
	+	+24 V DC	+24 V DC
		FE	Functional earth

1.2.5 Physical Description & Mounting

DIN rail mountable robust metallic housing for longevity in industrial environments.

Figure 1.1 Dimensions

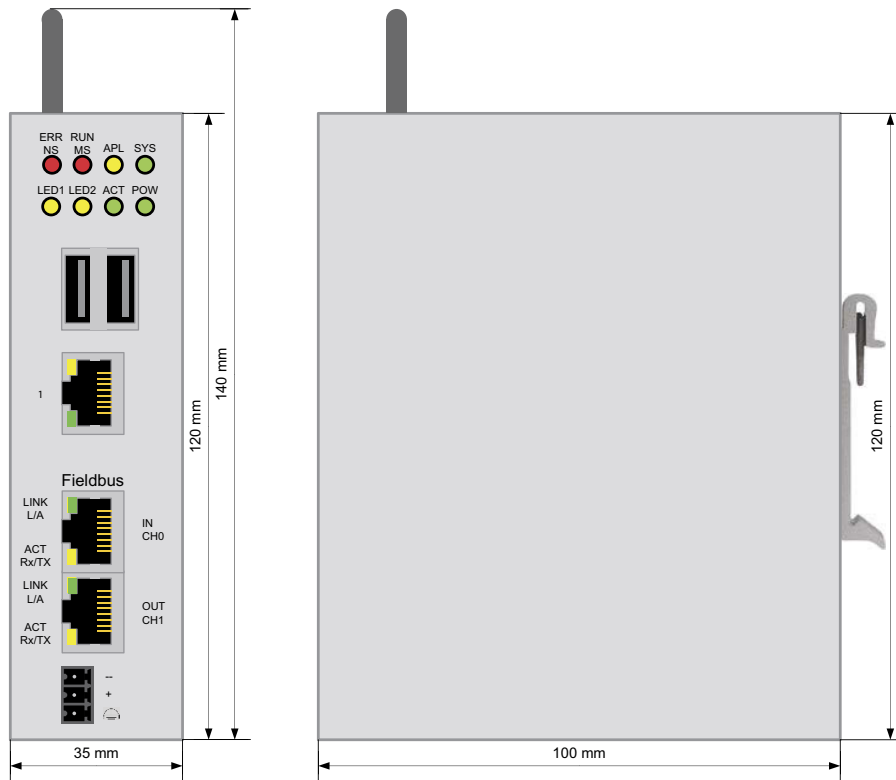

Table 1.5 Physical Description & Mounting

Parameter	Value
Dimensions (H x W x L)	140 mm x 35 mm x 105 mm
Weight	400 g
Housing	Metal
Mounting	DIN top hat rail

1.3 DIG Kits

1.3.1 Ethernet Gateway Kit (EDP 1027250)

Table 1.6 Ethernet Gateway Kit (EDP 1027250)

EDP	Description	Quantity
1027917	Ethernet Gateway Module	1
1018640	Ethernet Cable (2.5 m)	2
4000184	Software	1
1027921	USB Drive	1
1026686	User Manual	1

1.3.2 RS232 Gateway Kit (EDP 1027251)

Table 1.7 RS232 Gateway Kit (EDP 1027251)

EDP	Description	Quantity
1027917	Ethernet Gateway Module	1
1027918	RS232 to Ethernet Module	1
1018640	Ethernet Cable (2.5 m)	2
144-200-527	RS232 Straight Through Cable (2.5 m)	1
1027515	5 V 1 A Power Supply	1
4000184	Software	1
1027921	USB Drive	1
1026686	User Manual	1

1.4 Network Configuration

Branson products (supporting DIG) communicate via Ethernet LAN cables plugged in DIG RJ45 port "Fieldbus IN CH0".

Data Interface Gateway (DIG) is running an OPC-UA server on IT side, port 1.

NOTICE	
	The DIG is not intended to be directly connected to an enterprise or to an Internet-facing network without a compensating control in place.

1.4.1 Compatibility with Branson products

The Data Interface Gateway is compatible with the following Branson products:

- GVX/GLX/GIX/GVH/GL
- 2000Xc/2000X Series
- L20 Touchscreen
- L20 VersaGraphix

1.4.2 DIG Integration

There are 2 levels of DIG integration to the Branson products:

1. Branson equipment includes DIG in product's electrical installation. Branson equipment has external accessible RJ45 plug for direct connection to customer's network (see [Figure 1.2](#))
2. Branson equipment and the DIG are not installed as integrated components (see [Figure 1.3](#) and [Figure 1.4](#))

1.4.2.1 DIG is the integrated option in product/machine

Figure 1.2 Integrated DIG

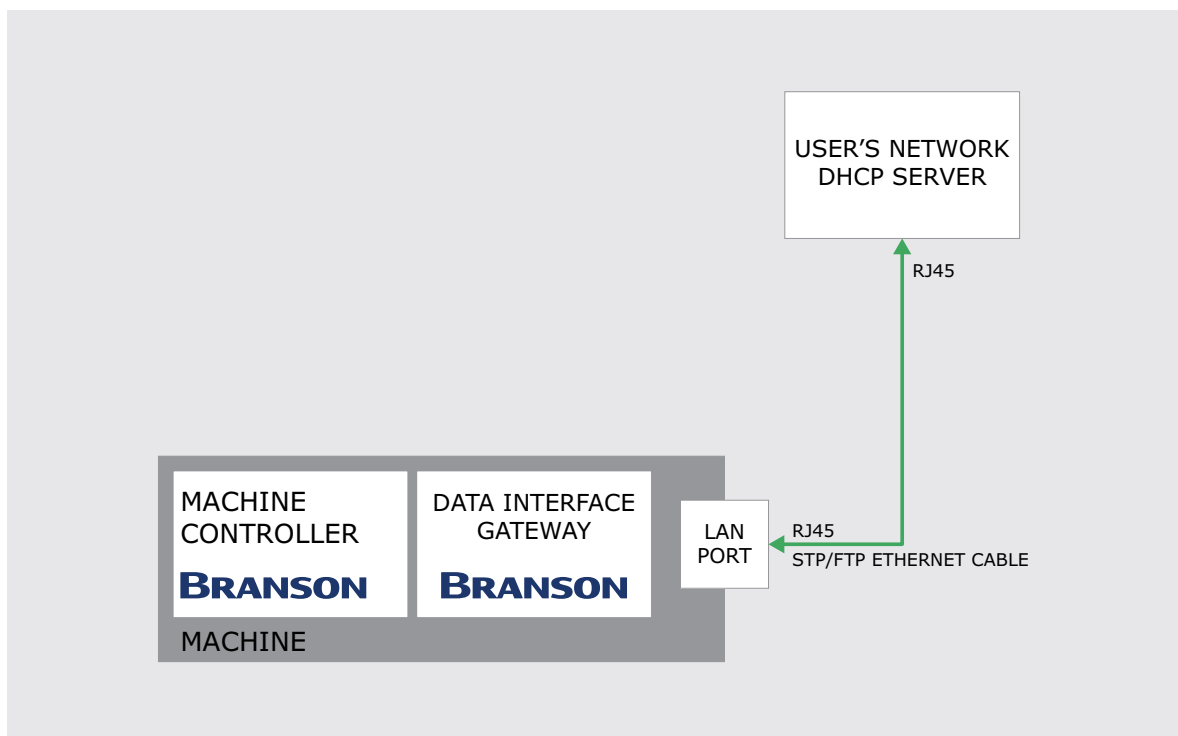

1.4.2.2 Aftermarket installation for a single or multiple machine connection

Figure 1.3 Ethernet Kit

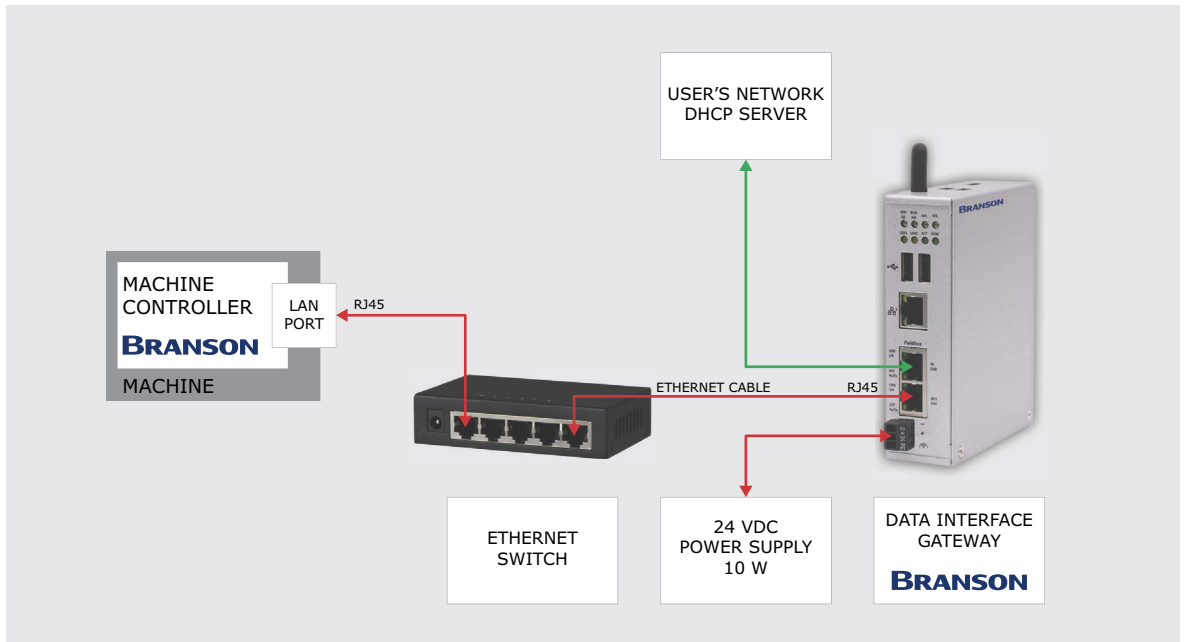

NOTICE



Ethernet switch is optional; it's only needed when connecting multiple machine controllers.

Figure 1.4 RS232 Kit

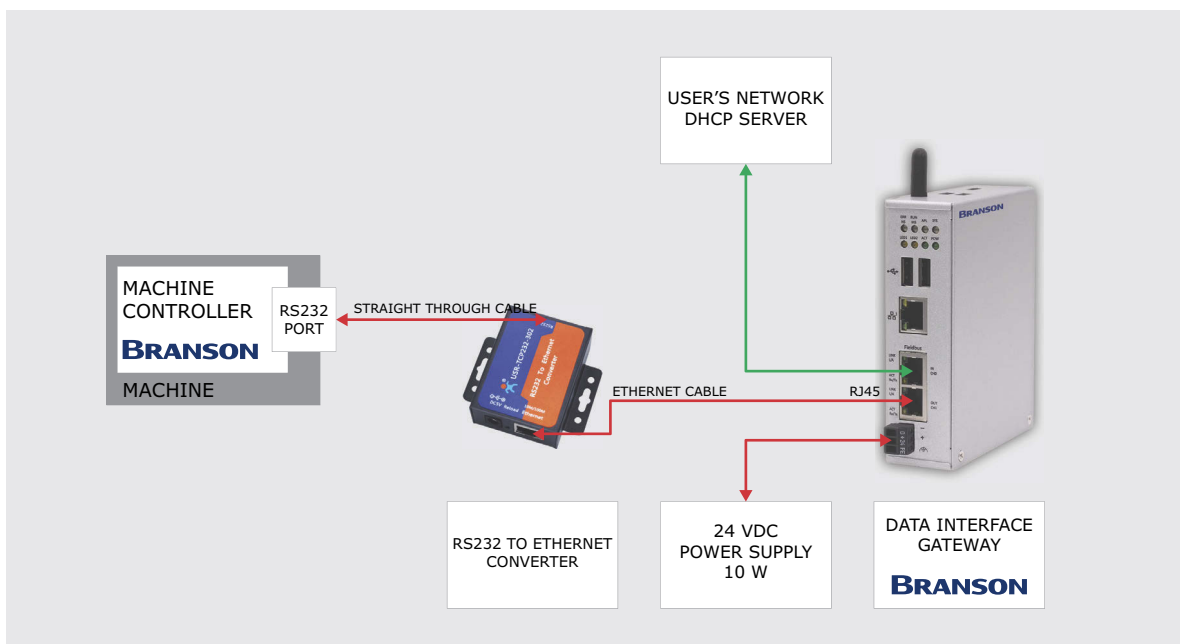

[This page intentionally left blank]

Chapter 2: Machine Settings

2.1	GVX/GLX/GIX/GVH/GL	16
2.2	Ultrasonic Welders	18
2.3	2000Xc Ultrasonic Welder	19
2.4	2000Xdt/2000Xea Ultrasonic Welder	21
2.5	L20 Touchscreen Machine	22
2.6	L20 VersaGraphix Machine	25
2.7	Data Interface Gateway (DIG)	27

2.1 GVX/GLX/GIX/GVH/GL

Machines with integrated DIG are shipped with functional settings. User can change them and configure which data and when are updated. Machine must have software version GXX.35131.s07.h02.069 or higher.

Table 2.1 GVX/GLX/GIX/GVH/GL Machines

Step	Description
1	Navigate to Admin > Settings > Interface screen
2	Select Data Provider 3

Set machine number. Machine number is always 1, just in case of networking more machines, every machine must have unique number from 1 to 10.

Figure 2.1 GVX/GLX/GIX/GVH/GL Machine Number

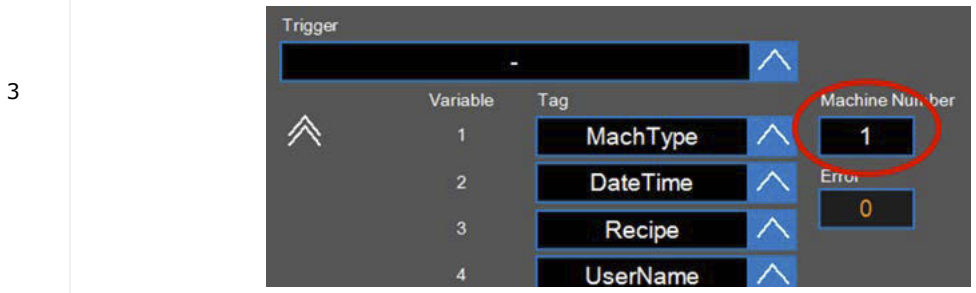

Data records settings. Data record is set of machine data which are updated when TRIGGER occurs. Record is a list of values which are free selectable.

Figure 2.2 GVX/GLX/GIX/GVH/GL Data Records

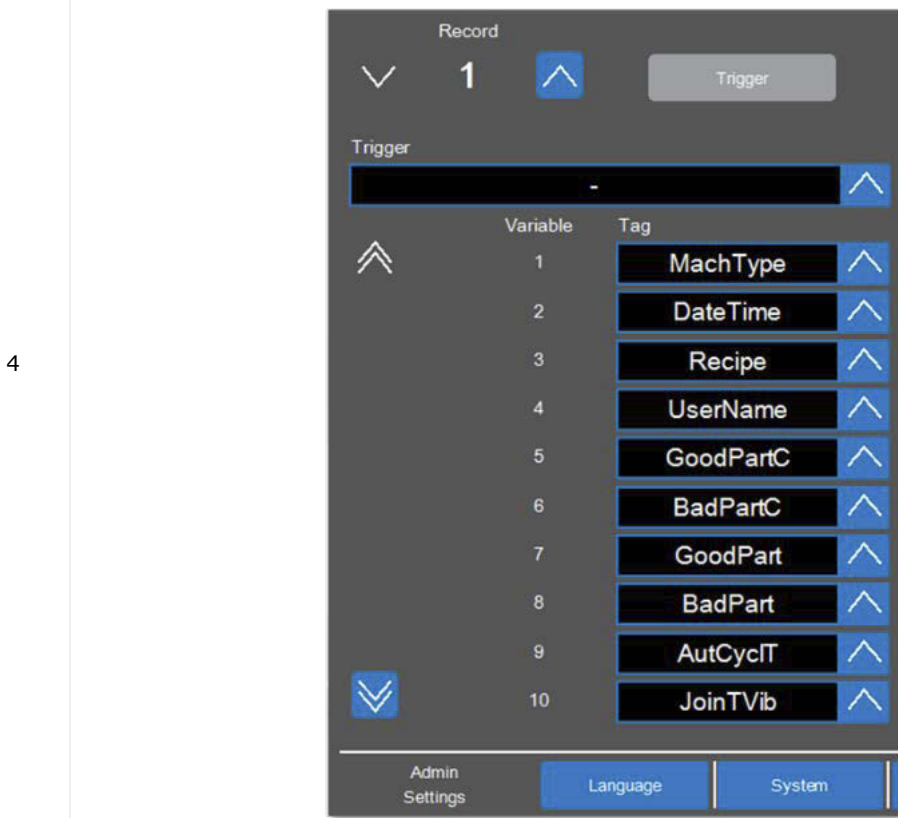



Table 2.1 GVX/GLX/GIX/GVH/GL Machines

Step	Description
5	<p>Turn Data Provider 3 on. This launches machine to DIG communication. Turn it off if you want to change settings or disable connection.</p> <p>Figure 2.3 GVX/GLX/GIX/GVH/GL On-Off Switch</p> 

2.2 Ultrasonic Welders

The DIG supports up to 10 machines. Each machine has assigned a static IP address and communicates with DIG on predefined port.

The network is defined as follows:

IP Address: 150.150.150.xx*

Subnet mask: 255.255.255.0

*(xx defines unique machine number, see [Table 2.2](#))

Machines are using static addresses from the subnet as shown in the following table:

Table 2.2 Machine/IP Address

Machine	Port	IP Address
Machine 01	65100	150.150.150.10
Machine 02	65101	150.150.150.11
...
Machine 10	65109	150.150.150.19

Settings are specific to product type, please find it listed below.

2.3 2000Xc Ultrasonic Welder

2000Xc can be connected to DIG if it has installed minimal control software version 12.4.

2.3.1 Configure IP Address

Table 2.3 Configure IP Address

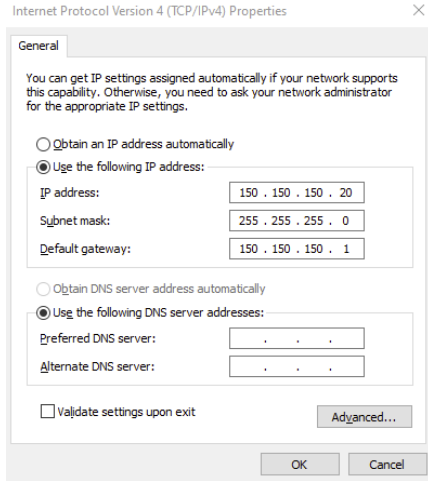
Step	Description
1	Disable FBWF (see section A.2 Disabling the FBWF Manager). It enables changes to the Windows Setup.
2	Navigate to System Configuration > Windows Setup.
3	From the Windows screen select: Start > Network Connections.
4	Double click Local Area Connection. Click Properties.
5	<p>Under Internet Protocol (TCP/IPv4), set the following IP address manually.</p> <p>Figure 2.4 Machine 1 TCP/IPv4 Properties</p> 
6	<p>Set your IP address: XX from Table 2.2 + 10</p> <p>For Machine 01 (150.150.150.10) for example, the windows setup IP has an address +10: IP: 150.150.150.20 Subnet Mask: 255.255.255.0</p>
7	Select OK (twice).
8	Close this window by clicking on the "X" on the upper right corner.

2.3.2 Configure the OPC UA Records (2000Xc)

Table 2.4 Configure the OPC UA Records (2000Xc)

Step	Description
1	Navigate to System Configuration > Data Transfer > DI Gateway.
	Navigate to System Configuration/Record Options to enable Records to be sent to the MES system. See Appendix B: Data Records for record information.

Figure 2.5 OPC UA Records



2.4 2000Xdt/2000Xea Ultrasonic Welder

2000Xdt/2000Xea can be connected to DIG if it has installed minimal control software version 11.36.

2.4.1 Module RS232 to Ethernet Setup

The Module RS232 to Ethernet is configured to Machine 01.

Table 2.5 Module RS232 to Ethernet Setup

Step	Description
1	Connect the converter to your PC via Ethernet cable.
2	Connect the RS232 Straight Through Cable between the machine J9 connector and the converter.

2.4.2 Configure the OPC UA Records (2000Xdt/2000Xea)

Table 2.6 Configure the OPC UA Records (2000Xdt/2000Xea)

Step	Description
1	Navigate to System Configuration > Data Transfer > DI Gateway.

Navigate to System Configuration/Record Options to enable Records to be sent to the MES system. See [Appendix B: Data Records](#) for record information.

Figure 2.6 OPC UA Records

2

2.5 L20 Touchscreen Machine

L20 Touchscreen machine can be connected to the DIG by using the Module RS232 to Ethernet (EDP 1026466) if it has installed minimal control software version v10.02.006.

Figure 2.7 L20 Touchscreen Software Version

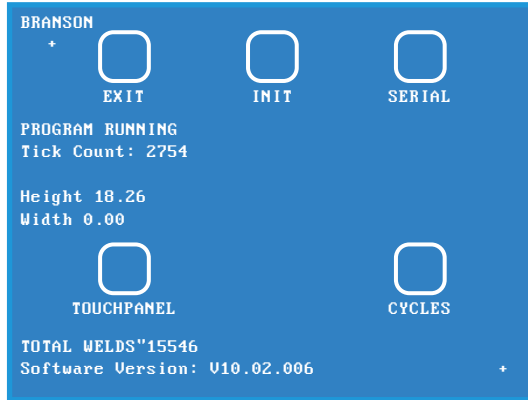

2.5.1 Enabling the Gateway Feature

Table 2.7 Enabling the Gateway Feature

Step	Description
1	<p>Press the Main Menu button to enter the Settings menu.</p> <p>Figure 2.8 Main Menu Button</p>

Table 2.7 Enabling the Gateway Feature



Step	Description
2	<p>Press the Config button.</p> <p>Figure 2.9 Menu Options</p> 
3	<p>Input the Level-2 Password and press Enter.</p> <ul style="list-style-type: none"> • Password: 2677 <p>Figure 2.10 Level-2 Password</p> 
4	<p>Press the Next button to the last page.</p> <p>Figure 2.11 System Configuration</p> 

Table 2.7 Enabling the Gateway Feature

Step	Description
5	<p>Press the Gateway button to enter the gateway feature settings.</p> <p>Figure 2.12 Gateway Button</p> 
6	<p>Enable the data type that you want to send to the gateway.</p> <p>Figure 2.13 Gateway Record Options</p> 

2.5.2 Module RS232 to Ethernet Setup

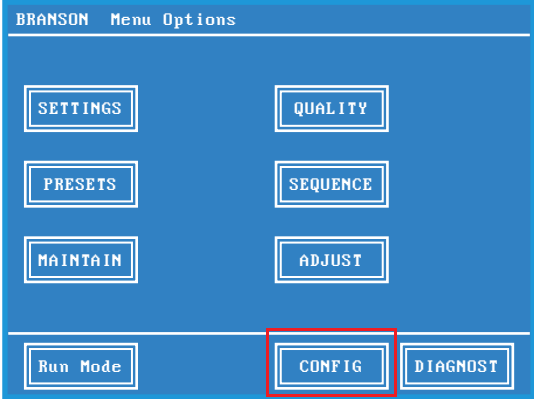
The Module RS232 to Ethernet is configured to Machine 01.

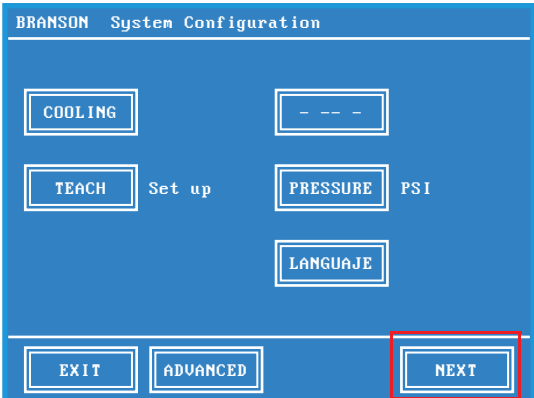
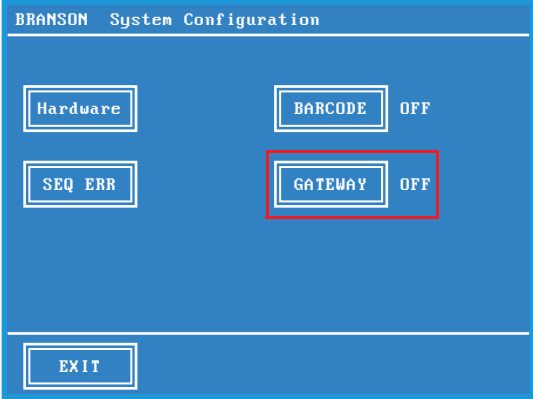
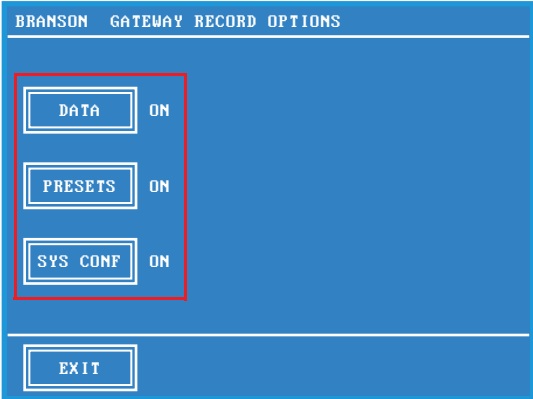
NOTICE	
	<p>To change the machine number, refer to Appendix D: RS232 to Ethernet Converter.</p>

Table 2.8 L20 Touchscreen Machine

Step	Description
1	Connect the converter to your PC via Ethernet cable.
2	Connect the RS232 Straight Through Cable between the machine barcode port and the converter.

2.6 L20 VersaGraphix Machine

L20 VersaGraphix machine can be connected to the DIG by using the Module RS232 to Ethernet (EDP 1026466) if it has installed minimal control software version BLD25.73.820.

Figure 2.14 L20 VersaGraphix Software Version

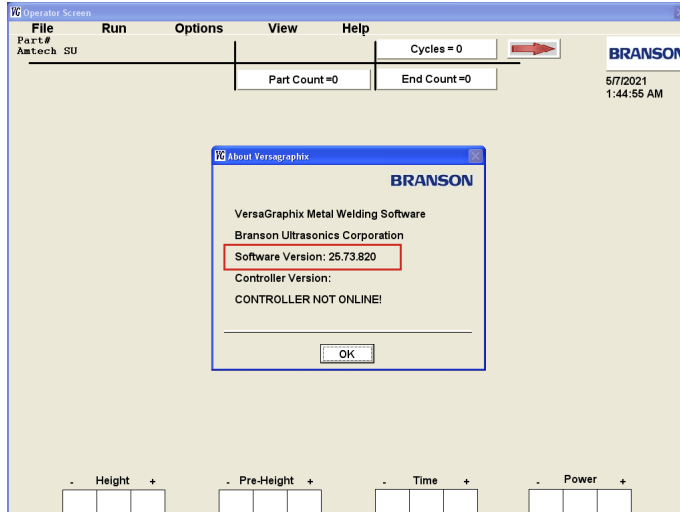

2.6.1 Enabling the Gateway Feature

Table 2.9 Enabling the Gateway Feature

Step	Description
1	<p>Navigate to Options > Configuration to enter the Configuration menu.</p> <p>Figure 2.15 Main Menu Button</p> 

Table 2.9 Enabling the Gateway Feature

Step	Description
2	<p>Enter the Admin password.</p> <p>Figure 2.16 Admin Password</p> 
3	<p>Navigate to the COM SETTINGS tab and enable the data type that you want to send to the gateway.</p> <p>Figure 2.17 Gateway Configuration</p> 

2.6.2 Module RS232 to Ethernet Setup

The Module RS232 to Ethernet is configured to Machine 01.

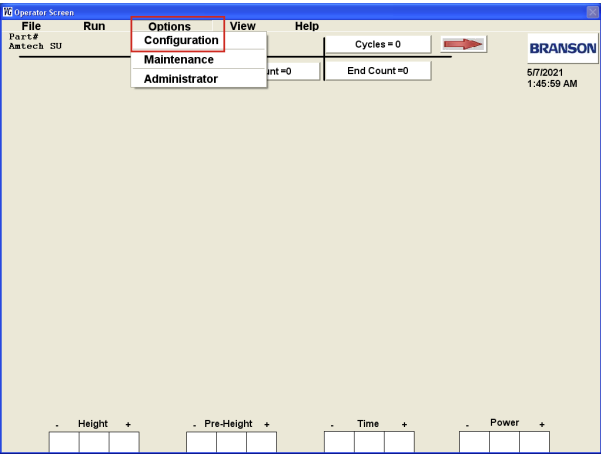
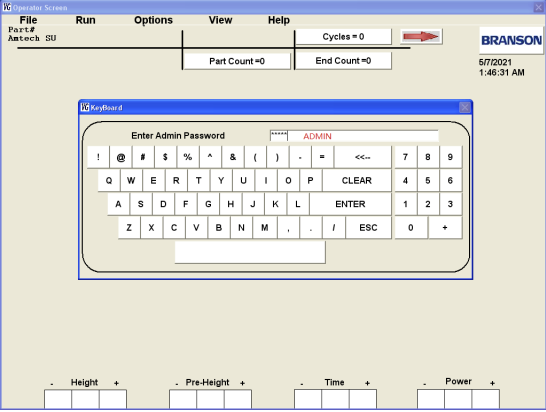
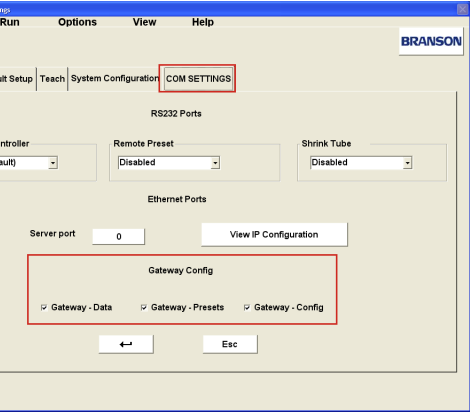
NOTICE	
	<p>To change the machine number, refer to Appendix D: RS232 to Ethernet Converter.</p>

Table 2.10 L20 Touchscreen Machine

Step	Description
1	Connect the converter to your PC via Ethernet cable.
2	Connect the RS232 Straight Through Cable between the machine barcode port and the converter.

2.7 Data Interface Gateway (DIG)

DIG automatically recognizes connected machines and updates data received from machines on OPC-UA server's interface.

OPC-UA client can access server by device host-name which is labeled either on DIG directly or also nearby machine network plug.

The device is delivered (factory setting) with a label printed at its bottom. See example below.

Figure 2.18 Device Label Example

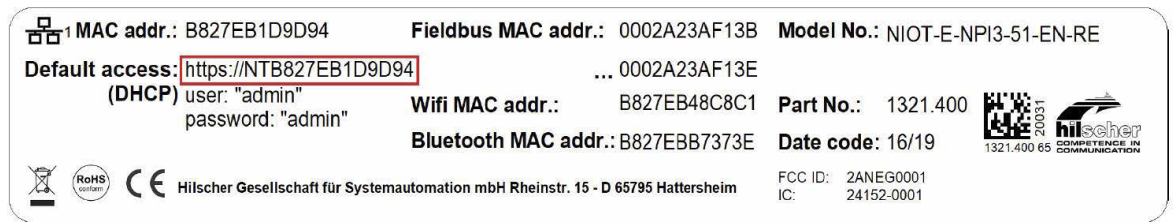

Some clients expect exact network URL, use the format in the example below:

opc.tcp://ntb827eb1d9d94:4840

NOTICE	
	If using a Static IP address use opc.tcp://xxx.xxx.xxx.xxx format.



2.7.1 DIG Settings

2.7.1.1 Establishing a Connection With the Host Name

Table 2.11 Establishing a Connection With the Host Name

Step	Description
1	<p>Enter the following address in the address bar of your browser: https://<hostname> Example: For the device with the host name NTB827EB1D9D94 enter: https:// NTB827EB1D9D94</p> <p>Figure 2.19 Address Bar</p>

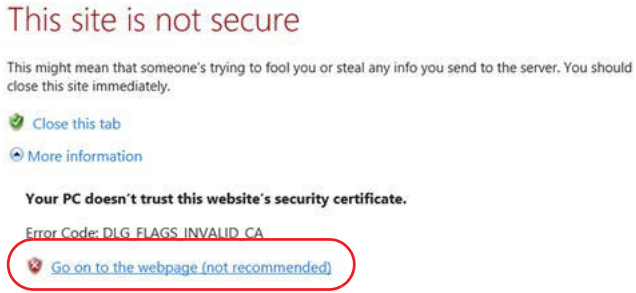
Table 2.11 Establishing a Connection With the Host Name

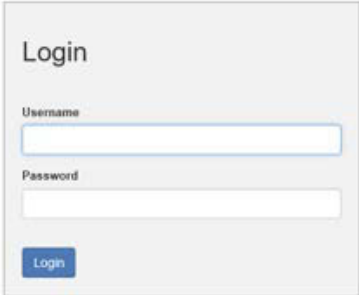
Step	Description
2	<p>Click the option Go on to the webpage.</p> <p>Figure 2.20 Security Error Message</p> 
3	<p>Click the Control Panel tab.</p> <p>Figure 2.21 Control Panel Tab</p> 
4	<p>Log in with the following credentials:</p> <ul style="list-style-type: none"> • Username: setup • Password: L42s3t*6 <p>Figure 2.22 Login</p> 

2.7.1.2 Configuring Ethernet Communication (LAN)

IT network settings can be modified according to end-user preferences.

It applies for OPC-UA networking and does not influence communication between DIG and Branson equipment.

Table 2.12 Change LAN Address

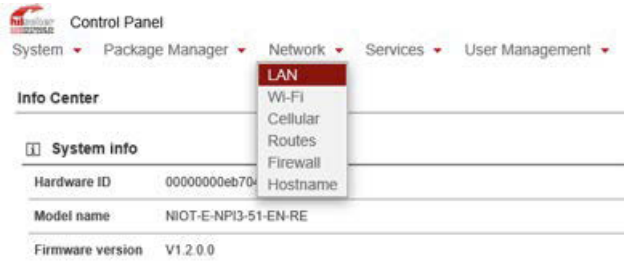
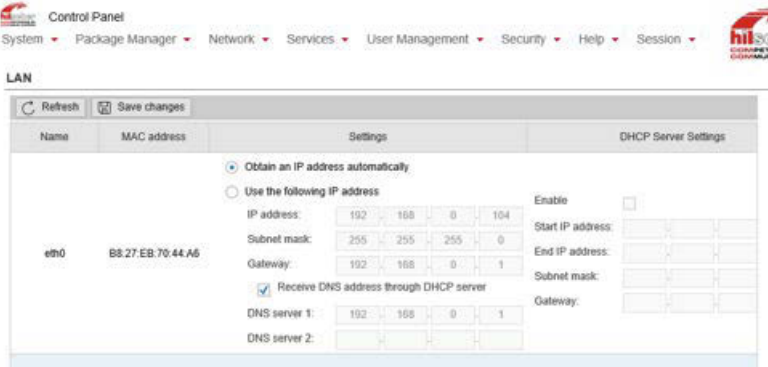
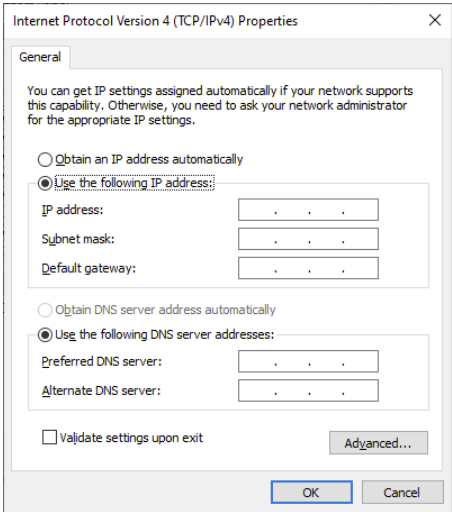
Step	Description
1	<p>Navigate to Network > LAN</p> <p>Figure 2.23 LAN Configuration</p>  <p>The screenshot shows the 'Control Panel' interface. At the top, there are navigation tabs: System, Package Manager, Network, Services, and User Management. The 'Network' tab is selected, and a dropdown menu is open, showing options: LAN (highlighted in red), Wi-Fi, Cellular, Routes, Firewall, and Hostname. Below the menu, the 'Info Center' section is visible, containing 'System info' with fields for Hardware ID (0000000eb704), Model name (NIOT-E-NPI3-51-EN-RE), and Firmware version (V1.2.0.0).</p>
2	<p>Modify network settings according to end-user network.</p> <p>Figure 2.24 LAN Configuration</p>  <p>The screenshot shows the 'LAN' configuration page. It has a 'Refresh' button and a 'Save changes' button. Below these are two columns: 'Settings' and 'DHCP Server Settings'. In the 'Settings' column, there are radio buttons for 'Obtain an IP address automatically' (selected) and 'Use the following IP address'. Below these are input fields for IP address (192.168.0.104), Subnet mask (255.255.255.0), and Gateway (192.168.0.1). There is also a checked checkbox for 'Receive DNS address through DHCP server' and fields for DNS server 1 (192.168.0.1) and DNS server 2. The 'DHCP Server Settings' column has an 'Enable' checkbox and fields for Start IP address, End IP address, Subnet mask, and Gateway.</p>
2	<p>Figure 2.25 End-user Network Settings</p>  <p>The screenshot shows the 'Internet Protocol Version 4 (TCP/IPv4) Properties' dialog box. It has a 'General' tab. The text inside says: 'You can get IP settings assigned automatically if your network supports this capability. Otherwise, you need to ask your network administrator for the appropriate IP settings.' There are two radio buttons: 'Obtain an IP address automatically' (unselected) and 'Use the following IP address:' (selected). Below these are input fields for IP address, Subnet mask, and Default gateway. There are also radio buttons for 'Obtain DNS server address automatically' (unselected) and 'Use the following DNS server addresses:' (selected). Below these are input fields for Preferred DNS server and Alternate DNS server. At the bottom, there is a checkbox for 'Validate settings upon exit' and an 'Advanced...' button. The 'OK' and 'Cancel' buttons are at the bottom right.</p>

2.7.1.3 Setting the System Time and Date

Navigate to System > Time:

Figure 2.26 Setting the System Time and Date



Figure 2.27 Control Panel - Date/Time Settings

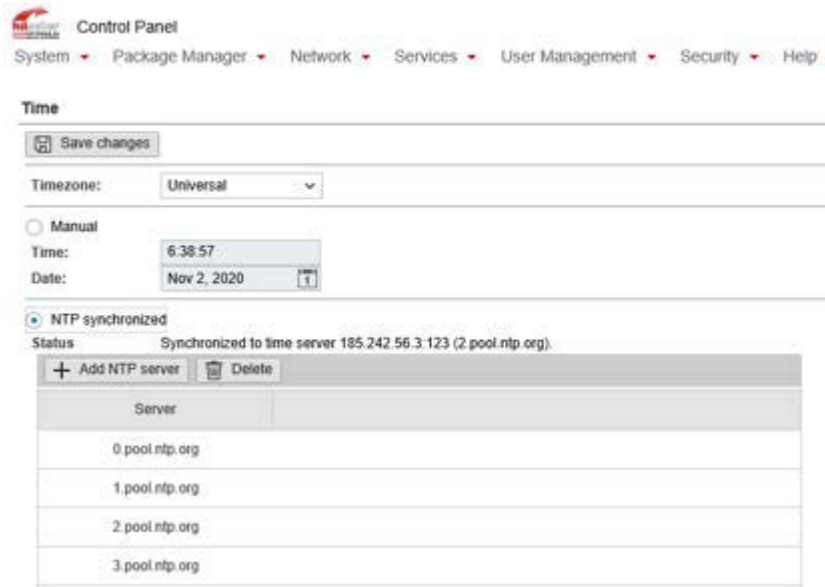

Setting the System Time Manually

Table 2.13 Setting the System Time Manually

Step	Description
1	Click the option Manual .
2	Enter the time in the input field Time in the format hh:mm:ss.
3	Set the date using the calendar input field Date .
4	Click Save changes .

Setting the System Time Automatically Using a Time Server

Table 2.14 Setting the System Time Automatically Using a Time Server

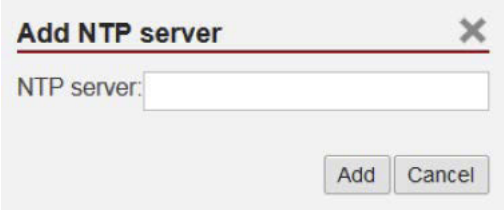
Step	Description
1	Click the option NTP Synchronized .
2	Click Add NTP server .
3	<p>The dialog box for entering the NTP server is displayed.</p> <p>Figure 2.28 NTP Server</p> 
4	Enter the address of a server which uses the NTP to synchronize the time.
5	Click Add .
6	Click Save changes .

NOTICE



Reboot the DIG for these changes to take effect.

2.7.2 OPC-UA Server: Data Format

NOTICE	
	See Appendix C: UaExpert Client for a demo OPC UA Client Software.

Server provides data in hierarchical structure:

- Machine[1]
 - Record[1]
 - Variable[1]
 - Tag Name (ascii string)
 - Value (unicode string)
 - Variable[2]
 - ...
 - Variable[20]
 - Record[2]
 - ...
 - Record[10]
- Machine[2]
- Machine[3]
- ...

Each machine connected to DIG is listed in an array with an index corresponding to the machine number. Machine number must be set on machine HMI. For example, if the machine number is set to 1, then the data from this machine can be found under Machine[1] item.

Machine data is further structured into records and variables. Record is set of variables. It depends on Branson product design, either records are preset with specific data or can be configured on machine HMI. See Appendix B for 2000Xc, GSX, and L20 Touchscreen specific data records.

Each variable consists of its tag and a value. Format of the tag is ASCII string. Tag identifies data value (part counter, amplitude, date and time etc.). Value's format is Unicode string for both numeric and text data.

Appendix A: FBWF Manager (2000Xc)

A.1	File Based Write Filter (FBWF)	34
A.2	Disabling the FBWF Manager.....	35

A.1 File Based Write Filter (FBWF)

The 2000Xc Power Supply SBC uses a solid state hard disk in the form of a CompactFlash card. While this CompactFlash card appears to be the same type used in digital cameras, it is a special industrial version which allows the Windows Embedded Standard operating system to boot.

To protect the application and the operating system, Windows Embedded Standard employs a File Based Write Filter (FBWF). This filter uses a RAM overlay to record changes to the CompactFlash card. Any changes made to the C: drive are lost during a power cycle. Only the C:\Branson folder remains unprotected allowing the 2000Xc Power Supply application to write directly to the CompactFlash card in order to save presets, sequences, setup parameters and log files.

The FBWF must be disabled before modifying the Windows Embedded Standard configuration. Changes made to Windows Embedded Standard configuration such as Local Area Network configuration will be lost if the FBWF has not been previously disabled. Once all changes have been saved, the FBWF must be re-enabled before resuming controller operations.

A.2 Disabling the FBWF Manager

Table A.1 Disabling the FBWF Manager

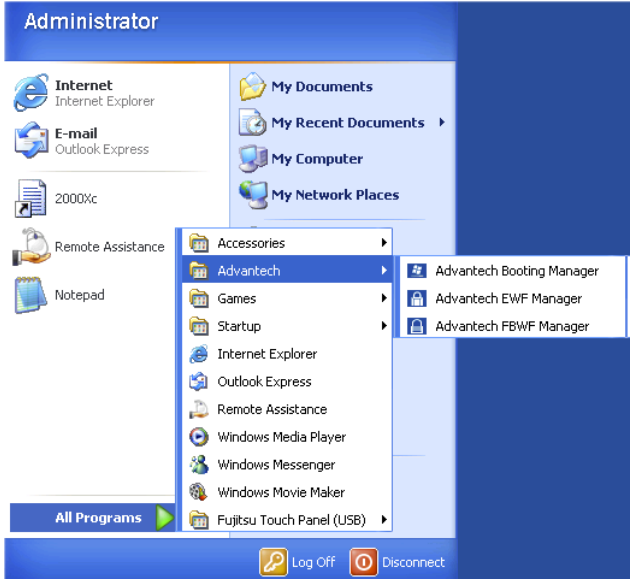
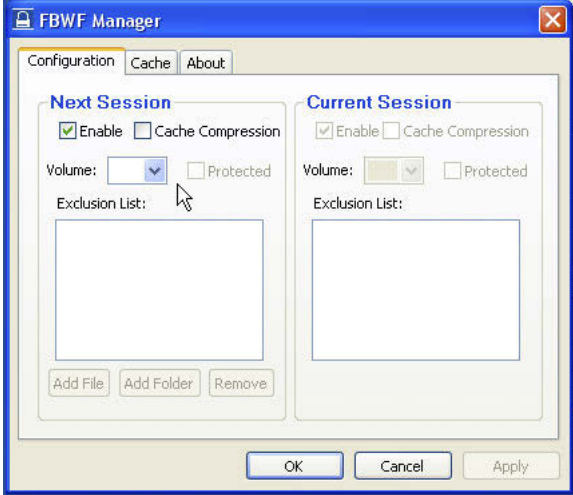
Step	Description
1	Navigate to System Configuration > Windows Setup.
2	<p>Open the FBWF Manager. Click on Start > All Programs > Advantech > Advantech FBWF Manager.</p> <p>Figure A.1 FBWF Manager Location</p> 
3	<p>Disable FBWF. Configuration > Next Session > [] Enable (uncheck box) > Volume C: > [] Protected (uncheck box). Click OK.</p> <p>Figure A.2 FBWF Manager</p> 
4	The following message will be displayed: "Do you want to apply your changes?". Click Yes.
5	The following message will be displayed: "Do you want to reboot now?". Click Yes.
6	Windows will shut down. Wait for Windows restart.

[This page intentionally left blank]

Appendix B: Data Records

B.1	GVX/GLX/GIX/GVH/GL.....	38
B.2	2000Xc/2000X Series	53
B.3	L20 Touchscreen & L20 VersaGraphix.	55

B.1 GVX/GLX/GIX/GVH/GL

Table B.1 Data Records for GVX/GLX/GIX/GVH/GL

Tag	Notes
AlarmAct	First Active Alarm
AmplAct	Actual Reached Amplitude for Vibration [mm]
AmplActP	Actual Amplitude at the end of actual Process step [mm]
AmplActP1	Actual Amplitude at the end of Process step 1 [mm]
AmplActP2	Actual Amplitude at the end of Process step 2 [mm]
AmplActP3	Actual Amplitude at the end of Process step 3 [mm]
AmplActP4	Actual Amplitude at the end of Process step 4 [mm]
AmplActP5	Actual Amplitude at the end of Process step 5 [mm]
AmplActP6	Actual Amplitude at the end of Process step 6 [mm]
AmplActP7	Actual Amplitude at the end of Process step 7 [mm]
AmplActP8	Actual Amplitude at the end of Process step 8 [mm]
AmplRef	Actual Reference Amplitude for Vibration [mm]
AmplRefP	Reference Amplitude at the end of actual Process step [mm]
AmplRefP1	Reference Amplitude at the end of Process step 1 [mm]
AmplRefP2	Reference Amplitude at the end of Process step 2 [mm]
AmplRefP3	Reference Amplitude at the end of Process step 3 [mm]
AmplRefP4	Reference Amplitude at the end of Process step 4 [mm]
AmplRefP5	Reference Amplitude at the end of Process step 5 [mm]
AmplRefP6	Reference Amplitude at the end of Process step 6 [mm]
AmplRefP7	Reference Amplitude at the end of Process step 7 [mm]
AmplRefP8	Reference Amplitude at the end of Process step 8 [mm]
AutCyclT	Automatic Cycle Time [s]
AutTAvg	Average from last 9 Automatic cycles [s]
BarCode1	Bar Code Reader 1 - Read Code
BarCode2	Bar Code Reader 2 - Read Code
CustName	Name of Customer
CycleCount	Total Cycle Counter
CycleFail	TRUE: Cycle failed during joining procedure
CycleFailC	Counter of failed cycles (shift counter)
CyclePass	TRUE: Cycle passed through joining procedure
CyclePassC	Counter of passed cycles (shift counter)
DateTime	Machine Date and Time (Format: '2018.05.05 22:19:01')
EmStopOk	Machine emergency stop is not activated

Table B.1 Data Records for GVX/GLX/GIX/GVH/GL

Tag	Notes
ForceAct	Actual Reached Force [daN]
ForceActP	Actual Force at the end of actual Process step [daN]
ForceActP1	Actual Force at the end of Process step 1 [daN]
ForceActP2	Actual Force at the end of Process step 2 [daN]
ForceActP3	Actual Force at the end of Process step 3 [daN]
ForceActP4	Actual Force at the end of Process step 4 [daN]
ForceActP5	Actual Force at the end of Process step 5 [daN]
ForceActP6	Actual Force at the end of Process step 6 [daN]
ForceActP7	Actual Force at the end of Process step 7 [daN]
ForceActP8	Actual Force at the end of Process step 8 [daN]
ForceRef	Actual Reference Force [daN]
ForceRefP	Reference Force at the end of actual Process step [daN]
ForceRefP1	Reference Force at the end of Process step 1 [daN]
ForceRefP2	Reference Force at the end of Process step 2 [daN]
ForceRefP3	Reference Force at the end of Process step 3 [daN]
ForceRefP4	Reference Force at the end of Process step 4 [daN]
ForceRefP5	Reference Force at the end of Process step 5 [daN]
ForceRefP6	Reference Force at the end of Process step 6 [daN]
ForceRefP7	Reference Force at the end of Process step 7 [daN]
ForceRefP8	Reference Force at the end of Process step 8 [daN]
FreqRefP	Reference Frequency at the end of actual Process step [Hz]
FreqRefP1	Reference Frequency at the end of Process step 1 [Hz]
FreqRefP2	Reference Frequency at the end of Process step 2 [Hz]
FreqRefP3	Reference Frequency at the end of Process step 3 [Hz]
FreqRefP4	Reference Frequency at the end of Process step 4 [Hz]
FreqRefP5	Reference Frequency at the end of Process step 5 [Hz]
FreqRefP6	Reference Frequency at the end of Process step 6 [Hz]
FreqRefP7	Reference Frequency at the end of Process step 7 [Hz]
FreqRefP8	Reference Frequency at the end of Process step 8 [Hz]
H1ActIP	IR-Emitter 1 Actual Current at the end of actual Process step [%]
H1ActIP1	IR-Emitter 1 Actual Current at the end of Process step 1 [%]
H1ActIP2	IR-Emitter 1 Actual Current at the end of Process step 2 [%]
H1ActIP3	IR-Emitter 1 Actual Current at the end of Process step 3 [%]
H1ActIP4	IR-Emitter 1 Actual Current at the end of Process step 4 [%]
H1ActIP5	IR-Emitter 1 Actual Current at the end of Process step 5 [%]
H1ActIP6	IR-Emitter 1 Actual Current at the end of Process step 6 [%]

Table B.1 Data Records for GVX/GLX/GIX/GVH/GL

Tag	Notes
H1ActIP7	IR-Emitter 1 Actual Current at the end of Process step 7 [%]
H1ActIP8	IR-Emitter 1 Actual Current at the end of Process step 8 [%]
H1ActVP	IR-Emitter 1 Actual Voltage at the end of actual Process step [%]
H1ActVP1	IR-Emitter 1 Actual Voltage at the end of Process step 1 [%]
H1ActVP2	IR-Emitter 1 Actual Voltage at the end of Process step 2 [%]
H1ActVP3	IR-Emitter 1 Actual Voltage at the end of Process step 3 [%]
H1ActVP4	IR-Emitter 1 Actual Voltage at the end of Process step 4 [%]
H1ActVP5	IR-Emitter 1 Actual Voltage at the end of Process step 5 [%]
H1ActVP6	IR-Emitter 1 Actual Voltage at the end of Process step 6 [%]
H1ActVP7	IR-Emitter 1 Actual Voltage at the end of Process step 7 [%]
H1ActVP8	IR-Emitter 1 Actual Voltage at the end of Process step 8 [%]
H1MTimeP	IR-Emitter 1 Motion Time at the end of actual Process step [s]
H1MTimeP1	IR-Emitter 1 Motion Time at the end of Process step 1 [s]
H1MTimeP2	IR-Emitter 1 Motion Time at the end of Process step 2 [s]
H1MTimeP3	IR-Emitter 1 Motion Time at the end of Process step 3 [s]
H1MTimeP4	IR-Emitter 1 Motion Time at the end of Process step 4 [s]
H1MTimeP5	IR-Emitter 1 Motion Time at the end of Process step 5 [s]
H1MTimeP6	IR-Emitter 1 Motion Time at the end of Process step 6 [s]
H1MTimeP7	IR-Emitter 1 Motion Time at the end of Process step 7 [s]
H1MTimeP8	IR-Emitter 1 Motion Time at the end of Process step 8 [s]
H1RefIP	IR-Emitter 1 Reference Current at the end of actual Process step [%]
H1RefIP1	IR-Emitter 1 Reference Current at the end of Process step 1 [%]
H1RefIP2	IR-Emitter 1 Reference Current at the end of Process step 2 [%]
H1RefIP3	IR-Emitter 1 Reference Current at the end of Process step 3 [%]
H1RefIP4	IR-Emitter 1 Reference Current at the end of Process step 4 [%]
H1RefIP5	IR-Emitter 1 Reference Current at the end of Process step 5 [%]
H1RefIP6	IR-Emitter 1 Reference Current at the end of Process step 6 [%]
H1RefIP7	IR-Emitter 1 Reference Current at the end of Process step 7 [%]
H1RefIP8	IR-Emitter 1 Reference Current at the end of Process step 8 [%]
H1RefVP	IR-Emitter 1 Reference Voltage at the end of actual Process step [%]
H1RefVP1	IR-Emitter 1 Reference Voltage at the end of Process step 1 [%]
H1RefVP2	IR-Emitter 1 Reference Voltage at the end of Process step 2 [%]
H1RefVP3	IR-Emitter 1 Reference Voltage at the end of Process step 3 [%]
H1RefVP4	IR-Emitter 1 Reference Voltage at the end of Process step 4 [%]
H1RefVP5	IR-Emitter 1 Reference Voltage at the end of Process step 5 [%]
H1RefVP6	IR-Emitter 1 Reference Voltage at the end of Process step 6 [%]

Table B.1 Data Records for GVX/GLX/GIX/GVH/GL

Tag	Notes
H1RefVP7	IR-Emitter 1 Reference Voltage at the end of Process step 7 [%]
H1RefVP8	IR-Emitter 1 Reference Voltage at the end of Process step 8 [%]
H2ActIP	IR-Emitter 2 Actual Current at the end of actual Process step [%]
H2ActIP1	IR-Emitter 2 Actual Current at the end of Process step 1 [%]
H2ActIP2	IR-Emitter 2 Actual Current at the end of Process step 2 [%]
H2ActIP3	IR-Emitter 2 Actual Current at the end of Process step 3 [%]
H2ActIP4	IR-Emitter 2 Actual Current at the end of Process step 4 [%]
H2ActIP5	IR-Emitter 2 Actual Current at the end of Process step 5 [%]
H2ActIP6	IR-Emitter 2 Actual Current at the end of Process step 6 [%]
H2ActIP7	IR-Emitter 2 Actual Current at the end of Process step 7 [%]
H2ActIP8	IR-Emitter 2 Actual Current at the end of Process step 8 [%]
H2ActVP	IR-Emitter 2 Actual Voltage at the end of actual Process step [%]
H2ActVP1	IR-Emitter 2 Actual Voltage at the end of Process step 1 [%]
H2ActVP2	IR-Emitter 2 Actual Voltage at the end of Process step 2 [%]
H2ActVP3	IR-Emitter 2 Actual Voltage at the end of Process step 3 [%]
H2ActVP4	IR-Emitter 2 Actual Voltage at the end of Process step 4 [%]
H2ActVP5	IR-Emitter 2 Actual Voltage at the end of Process step 5 [%]
H2ActVP6	IR-Emitter 2 Actual Voltage at the end of Process step 6 [%]
H2ActVP7	IR-Emitter 2 Actual Voltage at the end of Process step 7 [%]
H2ActVP8	IR-Emitter 2 Actual Voltage at the end of Process step 8 [%]
H2MTimeP	IR-Emitter 2 Motion Time at the end of actual Process step [s]
H2MTimeP1	IR-Emitter 2 Motion Time at the end of Process step 1 [s]
H2MTimeP2	IR-Emitter 2 Motion Time at the end of Process step 2 [s]
H2MTimeP3	IR-Emitter 2 Motion Time at the end of Process step 3 [s]
H2MTimeP4	IR-Emitter 2 Motion Time at the end of Process step 4 [s]
H2MTimeP5	IR-Emitter 2 Motion Time at the end of Process step 5 [s]
H2MTimeP6	IR-Emitter 2 Motion Time at the end of Process step 6 [s]
H2MTimeP7	IR-Emitter 2 Motion Time at the end of Process step 7 [s]
H2MTimeP8	IR-Emitter 2 Motion Time at the end of Process step 8 [s]
H2RefIP	IR-Emitter 2 Reference Current at the end of actual Process step [%]
H2RefIP1	IR-Emitter 2 Reference Current at the end of Process step 1 [%]
H2RefIP2	IR-Emitter 2 Reference Current at the end of Process step 2 [%]
H2RefIP3	IR-Emitter 2 Reference Current at the end of Process step 3 [%]
H2RefIP4	IR-Emitter 2 Reference Current at the end of Process step 4 [%]
H2RefIP5	IR-Emitter 2 Reference Current at the end of Process step 5 [%]
H2RefIP6	IR-Emitter 2 Reference Current at the end of Process step 6 [%]

Table B.1 Data Records for GVX/GLX/GIX/GVH/GL

Tag	Notes
H2RefIP7	IR-Emitter 2 Reference Current at the end of Process step 7 [%]
H2RefIP8	IR-Emitter 2 Reference Current at the end of Process step 8 [%]
H2RefVP	IR-Emitter 2 Reference Voltage at the end of actual Process step [%]
H2RefVP1	IR-Emitter 2 Reference Voltage at the end of Process step 1 [%]
H2RefVP2	IR-Emitter 2 Reference Voltage at the end of Process step 2 [%]
H2RefVP3	IR-Emitter 2 Reference Voltage at the end of Process step 3 [%]
H2RefVP4	IR-Emitter 2 Reference Voltage at the end of Process step 4 [%]
H2RefVP5	IR-Emitter 2 Reference Voltage at the end of Process step 5 [%]
H2RefVP6	IR-Emitter 2 Reference Voltage at the end of Process step 6 [%]
H2RefVP7	IR-Emitter 2 Reference Voltage at the end of Process step 7 [%]
H2RefVP8	IR-Emitter 2 Reference Voltage at the end of Process step 8 [%]
H3ActIP	IR-Emitter 3 Actual Current at the end of actual Process step [%]
H3ActIP1	IR-Emitter 3 Actual Current at the end of Process step 1 [%]
H3ActIP2	IR-Emitter 3 Actual Current at the end of Process step 2 [%]
H3ActIP3	IR-Emitter 3 Actual Current at the end of Process step 3 [%]
H3ActIP4	IR-Emitter 3 Actual Current at the end of Process step 4 [%]
H3ActIP5	IR-Emitter 3 Actual Current at the end of Process step 5 [%]
H3ActIP6	IR-Emitter 3 Actual Current at the end of Process step 6 [%]
H3ActIP7	IR-Emitter 3 Actual Current at the end of Process step 7 [%]
H3ActIP8	IR-Emitter 3 Actual Current at the end of Process step 8 [%]
H3ActVP	IR-Emitter 3 Actual Voltage at the end of actual Process step [%]
H3ActVP1	IR-Emitter 3 Actual Voltage at the end of Process step 1 [%]
H3ActVP2	IR-Emitter 3 Actual Voltage at the end of Process step 2 [%]
H3ActVP3	IR-Emitter 3 Actual Voltage at the end of Process step 3 [%]
H3ActVP4	IR-Emitter 3 Actual Voltage at the end of Process step 4 [%]
H3ActVP5	IR-Emitter 3 Actual Voltage at the end of Process step 5 [%]
H3ActVP6	IR-Emitter 3 Actual Voltage at the end of Process step 6 [%]
H3ActVP7	IR-Emitter 3 Actual Voltage at the end of Process step 7 [%]
H3ActVP8	IR-Emitter 3 Actual Voltage at the end of Process step 8 [%]
H3MTimeP	IR-Emitter 3 Motion Time at the end of actual Process step [s]
H3MTimeP1	IR-Emitter 3 Motion Time at the end of Process step 1 [s]
H3MTimeP2	IR-Emitter 3 Motion Time at the end of Process step 2 [s]
H3MTimeP3	IR-Emitter 3 Motion Time at the end of Process step 3 [s]
H3MTimeP4	IR-Emitter 3 Motion Time at the end of Process step 4 [s]
H3MTimeP5	IR-Emitter 3 Motion Time at the end of Process step 5 [s]
H3MTimeP6	IR-Emitter 3 Motion Time at the end of Process step 6 [s]

Table B.1 Data Records for GVX/GLX/GIX/GVH/GL

Tag	Notes
H3MTimeP7	IR-Emitter 3 Motion Time at the end of Process step 7 [s]
H3MTimeP8	IR-Emitter 3 Motion Time at the end of Process step 8 [s]
H3RefIP	IR-Emitter 3 Reference Current at the end of actual Process step [%]
H3RefIP1	IR-Emitter 3 Reference Current at the end of Process step 1 [%]
H3RefIP2	IR-Emitter 3 Reference Current at the end of Process step 2 [%]
H3RefIP3	IR-Emitter 3 Reference Current at the end of Process step 3 [%]
H3RefIP4	IR-Emitter 3 Reference Current at the end of Process step 4 [%]
H3RefIP5	IR-Emitter 3 Reference Current at the end of Process step 5 [%]
H3RefIP6	IR-Emitter 3 Reference Current at the end of Process step 6 [%]
H3RefIP7	IR-Emitter 3 Reference Current at the end of Process step 7 [%]
H3RefIP8	IR-Emitter 3 Reference Current at the end of Process step 8 [%]
H3RefVP	IR-Emitter 3 Reference Voltage at the end of actual Process step [%]
H3RefVP1	IR-Emitter 3 Reference Voltage at the end of Process step 1 [%]
H3RefVP2	IR-Emitter 3 Reference Voltage at the end of Process step 2 [%]
H3RefVP3	IR-Emitter 3 Reference Voltage at the end of Process step 3 [%]
H3RefVP4	IR-Emitter 3 Reference Voltage at the end of Process step 4 [%]
H3RefVP5	IR-Emitter 3 Reference Voltage at the end of Process step 5 [%]
H3RefVP6	IR-Emitter 3 Reference Voltage at the end of Process step 6 [%]
H3RefVP7	IR-Emitter 3 Reference Voltage at the end of Process step 7 [%]
H3RefVP8	IR-Emitter 3 Reference Voltage at the end of Process step 8 [%]
H4ActIP	IR-Emitter 4 Actual Current at the end of actual Process step [%]
H4ActIP1	IR-Emitter 4 Actual Current at the end of Process step 1 [%]
H4ActIP2	IR-Emitter 4 Actual Current at the end of Process step 2 [%]
H4ActIP3	IR-Emitter 4 Actual Current at the end of Process step 3 [%]
H4ActIP4	IR-Emitter 4 Actual Current at the end of Process step 4 [%]
H4ActIP5	IR-Emitter 4 Actual Current at the end of Process step 5 [%]
H4ActIP6	IR-Emitter 4 Actual Current at the end of Process step 6 [%]
H4ActIP7	IR-Emitter 4 Actual Current at the end of Process step 7 [%]
H4ActIP8	IR-Emitter 4 Actual Current at the end of Process step 8 [%]
H4ActVP	IR-Emitter 4 Actual Voltage at the end of actual Process step [%]
H4ActVP1	IR-Emitter 4 Actual Voltage at the end of Process step 1 [%]
H4ActVP2	IR-Emitter 4 Actual Voltage at the end of Process step 2 [%]
H4ActVP3	IR-Emitter 4 Actual Voltage at the end of Process step 3 [%]
H4ActVP4	IR-Emitter 4 Actual Voltage at the end of Process step 4 [%]
H4ActVP5	IR-Emitter 4 Actual Voltage at the end of Process step 5 [%]
H4ActVP6	IR-Emitter 4 Actual Voltage at the end of Process step 6 [%]

Table B.1 Data Records for GVX/GLX/GIX/GVH/GL

Tag	Notes
H4ActVP7	IR-Emitter 4 Actual Voltage at the end of Process step 7 [%]
H4ActVP8	IR-Emitter 4 Actual Voltage at the end of Process step 8 [%]
H4MTimeP	IR-Emitter 4 Motion Time at the end of actual Process step [s]
H4MTimeP1	IR-Emitter 4 Motion Time at the end of Process step 1 [s]
H4MTimeP2	IR-Emitter 4 Motion Time at the end of Process step 2 [s]
H4MTimeP3	IR-Emitter 4 Motion Time at the end of Process step 3 [s]
H4MTimeP4	IR-Emitter 4 Motion Time at the end of Process step 4 [s]
H4MTimeP5	IR-Emitter 4 Motion Time at the end of Process step 5 [s]
H4MTimeP6	IR-Emitter 4 Motion Time at the end of Process step 6 [s]
H4MTimeP7	IR-Emitter 4 Motion Time at the end of Process step 7 [s]
H4MTimeP8	IR-Emitter 4 Motion Time at the end of Process step 8 [s]
H4RefIP	IR-Emitter 4 Reference Current at the end of actual Process step [%]
H4RefIP1	IR-Emitter 4 Reference Current at the end of Process step 1 [%]
H4RefIP2	IR-Emitter 4 Reference Current at the end of Process step 2 [%]
H4RefIP3	IR-Emitter 4 Reference Current at the end of Process step 3 [%]
H4RefIP4	IR-Emitter 4 Reference Current at the end of Process step 4 [%]
H4RefIP5	IR-Emitter 4 Reference Current at the end of Process step 5 [%]
H4RefIP6	IR-Emitter 4 Reference Current at the end of Process step 6 [%]
H4RefIP7	IR-Emitter 4 Reference Current at the end of Process step 7 [%]
H4RefIP8	IR-Emitter 4 Reference Current at the end of Process step 8 [%]
H4RefVP	IR-Emitter 4 Reference Voltage at the end of actual Process step [%]
H4RefVP1	IR-Emitter 4 Reference Voltage at the end of Process step 1 [%]
H4RefVP2	IR-Emitter 4 Reference Voltage at the end of Process step 2 [%]
H4RefVP3	IR-Emitter 4 Reference Voltage at the end of Process step 3 [%]
H4RefVP4	IR-Emitter 4 Reference Voltage at the end of Process step 4 [%]
H4RefVP5	IR-Emitter 4 Reference Voltage at the end of Process step 5 [%]
H4RefVP6	IR-Emitter 4 Reference Voltage at the end of Process step 6 [%]
H4RefVP7	IR-Emitter 4 Reference Voltage at the end of Process step 7 [%]
H4RefVP8	IR-Emitter 4 Reference Voltage at the end of Process step 8 [%]
H5ActIP	IR-Emitter 5 Actual Current at the end of actual Process step [%]
H5ActIP1	IR-Emitter 5 Actual Current at the end of Process step 1 [%]
H5ActIP2	IR-Emitter 5 Actual Current at the end of Process step 2 [%]
H5ActIP3	IR-Emitter 5 Actual Current at the end of Process step 3 [%]
H5ActIP4	IR-Emitter 5 Actual Current at the end of Process step 4 [%]
H5ActIP5	IR-Emitter 5 Actual Current at the end of Process step 5 [%]
H5ActIP6	IR-Emitter 5 Actual Current at the end of Process step 6 [%]

Table B.1 Data Records for GVX/GLX/GIX/GVH/GL

Tag	Notes
H5ActIP7	IR-Emitter 5 Actual Current at the end of Process step 7 [%]
H5ActIP8	IR-Emitter 5 Actual Current at the end of Process step 8 [%]
H5ActVP	IR-Emitter 5 Actual Voltage at the end of actual Process step [%]
H5ActVP1	IR-Emitter 5 Actual Voltage at the end of Process step 1 [%]
H5ActVP2	IR-Emitter 5 Actual Voltage at the end of Process step 2 [%]
H5ActVP3	IR-Emitter 5 Actual Voltage at the end of Process step 3 [%]
H5ActVP4	IR-Emitter 5 Actual Voltage at the end of Process step 4 [%]
H5ActVP5	IR-Emitter 5 Actual Voltage at the end of Process step 5 [%]
H5ActVP6	IR-Emitter 5 Actual Voltage at the end of Process step 6 [%]
H5ActVP7	IR-Emitter 5 Actual Voltage at the end of Process step 7 [%]
H5ActVP8	IR-Emitter 5 Actual Voltage at the end of Process step 8 [%]
H5MTimeP	IR-Emitter 5 Motion Time at the end of actual Process step [s]
H5MTimeP1	IR-Emitter 5 Motion Time at the end of Process step 1 [s]
H5MTimeP2	IR-Emitter 5 Motion Time at the end of Process step 2 [s]
H5MTimeP3	IR-Emitter 5 Motion Time at the end of Process step 3 [s]
H5MTimeP4	IR-Emitter 5 Motion Time at the end of Process step 4 [s]
H5MTimeP5	IR-Emitter 5 Motion Time at the end of Process step 5 [s]
H5MTimeP6	IR-Emitter 5 Motion Time at the end of Process step 6 [s]
H5MTimeP7	IR-Emitter 5 Motion Time at the end of Process step 7 [s]
H5MTimeP8	IR-Emitter 5 Motion Time at the end of Process step 8 [s]
H5RefIP	IR-Emitter 5 Reference Current at the end of actual Process step [%]
H5RefIP1	IR-Emitter 5 Reference Current at the end of Process step 1 [%]
H5RefIP2	IR-Emitter 5 Reference Current at the end of Process step 2 [%]
H5RefIP3	IR-Emitter 5 Reference Current at the end of Process step 3 [%]
H5RefIP4	IR-Emitter 5 Reference Current at the end of Process step 4 [%]
H5RefIP5	IR-Emitter 5 Reference Current at the end of Process step 5 [%]
H5RefIP6	IR-Emitter 5 Reference Current at the end of Process step 6 [%]
H5RefIP7	IR-Emitter 5 Reference Current at the end of Process step 7 [%]
H5RefIP8	IR-Emitter 5 Reference Current at the end of Process step 8 [%]
H5RefVP	IR-Emitter 5 Reference Voltage at the end of actual Process step [%]
H5RefVP1	IR-Emitter 5 Reference Voltage at the end of Process step 1 [%]
H5RefVP2	IR-Emitter 5 Reference Voltage at the end of Process step 2 [%]
H5RefVP3	IR-Emitter 5 Reference Voltage at the end of Process step 3 [%]
H5RefVP4	IR-Emitter 5 Reference Voltage at the end of Process step 4 [%]
H5RefVP5	IR-Emitter 5 Reference Voltage at the end of Process step 5 [%]
H5RefVP6	IR-Emitter 5 Reference Voltage at the end of Process step 6 [%]

Table B.1 Data Records for GVX/GLX/GIX/GVH/GL

Tag	Notes
H5RefVP7	IR-Emitter 5 Reference Voltage at the end of Process step 7 [%]
H5RefVP8	IR-Emitter 5 Reference Voltage at the end of Process step 8 [%]
H6ActIP	IR-Emitter 6 Actual Current at the end of actual Process step [%]
H6ActIP1	IR-Emitter 6 Actual Current at the end of Process step 1 [%]
H6ActIP2	IR-Emitter 6 Actual Current at the end of Process step 2 [%]
H6ActIP3	IR-Emitter 6 Actual Current at the end of Process step 3 [%]
H6ActIP4	IR-Emitter 6 Actual Current at the end of Process step 4 [%]
H6ActIP5	IR-Emitter 6 Actual Current at the end of Process step 5 [%]
H6ActIP6	IR-Emitter 6 Actual Current at the end of Process step 6 [%]
H6ActIP7	IR-Emitter 6 Actual Current at the end of Process step 7 [%]
H6ActIP8	IR-Emitter 6 Actual Current at the end of Process step 8 [%]
H6ActVP	IR-Emitter 6 Actual Voltage at the end of actual Process step [%]
H6ActVP1	IR-Emitter 6 Actual Voltage at the end of Process step 1 [%]
H6ActVP2	IR-Emitter 6 Actual Voltage at the end of Process step 2 [%]
H6ActVP3	IR-Emitter 6 Actual Voltage at the end of Process step 3 [%]
H6ActVP4	IR-Emitter 6 Actual Voltage at the end of Process step 4 [%]
H6ActVP5	IR-Emitter 6 Actual Voltage at the end of Process step 5 [%]
H6ActVP6	IR-Emitter 6 Actual Voltage at the end of Process step 6 [%]
H6ActVP7	IR-Emitter 6 Actual Voltage at the end of Process step 7 [%]
H6ActVP8	IR-Emitter 6 Actual Voltage at the end of Process step 8 [%]
H6MTimeP	IR-Emitter 6 Motion Time at the end of actual Process step [s]
H6MTimeP1	IR-Emitter 6 Motion Time at the end of Process step 1 [s]
H6MTimeP2	IR-Emitter 6 Motion Time at the end of Process step 2 [s]
H6MTimeP3	IR-Emitter 6 Motion Time at the end of Process step 3 [s]
H6MTimeP4	IR-Emitter 6 Motion Time at the end of Process step 4 [s]
H6MTimeP5	IR-Emitter 6 Motion Time at the end of Process step 5 [s]
H6MTimeP6	IR-Emitter 6 Motion Time at the end of Process step 6 [s]
H6MTimeP7	IR-Emitter 6 Motion Time at the end of Process step 7 [s]
H6MTimeP8	IR-Emitter 6 Motion Time at the end of Process step 8 [s]
H6RefIP	IR-Emitter 6 Reference Current at the end of actual Process step [%]
H6RefIP1	IR-Emitter 6 Reference Current at the end of Process step 1 [%]
H6RefIP2	IR-Emitter 6 Reference Current at the end of Process step 2 [%]
H6RefIP3	IR-Emitter 6 Reference Current at the end of Process step 3 [%]
H6RefIP4	IR-Emitter 6 Reference Current at the end of Process step 4 [%]
H6RefIP5	IR-Emitter 6 Reference Current at the end of Process step 5 [%]
H6RefIP6	IR-Emitter 6 Reference Current at the end of Process step 6 [%]

Table B.1 Data Records for GVX/GLX/GIX/GVH/GL

Tag	Notes
H6RefIP7	IR-Emitter 6 Reference Current at the end of Process step 7 [%]
H6RefIP8	IR-Emitter 6 Reference Current at the end of Process step 8 [%]
H6RefVP	IR-Emitter 6 Reference Voltage at the end of actual Process step [%]
H6RefVP1	IR-Emitter 6 Reference Voltage at the end of Process step 1 [%]
H6RefVP2	IR-Emitter 6 Reference Voltage at the end of Process step 2 [%]
H6RefVP3	IR-Emitter 6 Reference Voltage at the end of Process step 3 [%]
H6RefVP4	IR-Emitter 6 Reference Voltage at the end of Process step 4 [%]
H6RefVP5	IR-Emitter 6 Reference Voltage at the end of Process step 5 [%]
H6RefVP6	IR-Emitter 6 Reference Voltage at the end of Process step 6 [%]
H6RefVP7	IR-Emitter 6 Reference Voltage at the end of Process step 7 [%]
H6RefVP8	IR-Emitter 6 Reference Voltage at the end of Process step 8 [%]
H7ActIP	IR-Emitter 7 Actual Current at the end of actual Process step [%]
H7ActIP1	IR-Emitter 7 Actual Current at the end of Process step 1 [%]
H7ActIP2	IR-Emitter 7 Actual Current at the end of Process step 2 [%]
H7ActIP3	IR-Emitter 7 Actual Current at the end of Process step 3 [%]
H7ActIP4	IR-Emitter 7 Actual Current at the end of Process step 4 [%]
H7ActIP5	IR-Emitter 7 Actual Current at the end of Process step 5 [%]
H7ActIP6	IR-Emitter 7 Actual Current at the end of Process step 6 [%]
H7ActIP7	IR-Emitter 7 Actual Current at the end of Process step 7 [%]
H7ActIP8	IR-Emitter 7 Actual Current at the end of Process step 8 [%]
H7ActVP	IR-Emitter 7 Actual Voltage at the end of actual Process step [%]
H7ActVP1	IR-Emitter 7 Actual Voltage at the end of Process step 1 [%]
H7ActVP2	IR-Emitter 7 Actual Voltage at the end of Process step 2 [%]
H7ActVP3	IR-Emitter 7 Actual Voltage at the end of Process step 3 [%]
H7ActVP4	IR-Emitter 7 Actual Voltage at the end of Process step 4 [%]
H7ActVP5	IR-Emitter 7 Actual Voltage at the end of Process step 5 [%]
H7ActVP6	IR-Emitter 7 Actual Voltage at the end of Process step 6 [%]
H7ActVP7	IR-Emitter 7 Actual Voltage at the end of Process step 7 [%]
H7ActVP8	IR-Emitter 7 Actual Voltage at the end of Process step 8 [%]
H7MTimeP	IR-Emitter 7 Motion Time at the end of actual Process step [s]
H7MTimeP1	IR-Emitter 7 Motion Time at the end of Process step 1 [s]
H7MTimeP2	IR-Emitter 7 Motion Time at the end of Process step 2 [s]
H7MTimeP3	IR-Emitter 7 Motion Time at the end of Process step 3 [s]
H7MTimeP4	IR-Emitter 7 Motion Time at the end of Process step 4 [s]
H7MTimeP5	IR-Emitter 7 Motion Time at the end of Process step 5 [s]
H7MTimeP6	IR-Emitter 7 Motion Time at the end of Process step 6 [s]

Table B.1 Data Records for GVX/GLX/GIX/GVH/GL

Tag	Notes
H7MTimeP7	IR-Emitter 7 Motion Time at the end of Process step 7 [s]
H7MTimeP8	IR-Emitter 7 Motion Time at the end of Process step 8 [s]
H7RefIP	IR-Emitter 7 Reference Current at the end of actual Process step [%]
H7RefIP1	IR-Emitter 7 Reference Current at the end of Process step 1 [%]
H7RefIP2	IR-Emitter 7 Reference Current at the end of Process step 2 [%]
H7RefIP3	IR-Emitter 7 Reference Current at the end of Process step 3 [%]
H7RefIP4	IR-Emitter 7 Reference Current at the end of Process step 4 [%]
H7RefIP5	IR-Emitter 7 Reference Current at the end of Process step 5 [%]
H7RefIP6	IR-Emitter 7 Reference Current at the end of Process step 6 [%]
H7RefIP7	IR-Emitter 7 Reference Current at the end of Process step 7 [%]
H7RefIP8	IR-Emitter 7 Reference Current at the end of Process step 8 [%]
H7RefVP	IR-Emitter 7 Reference Voltage at the end of actual Process step [%]
H7RefVP1	IR-Emitter 7 Reference Voltage at the end of Process step 1 [%]
H7RefVP2	IR-Emitter 7 Reference Voltage at the end of Process step 2 [%]
H7RefVP3	IR-Emitter 7 Reference Voltage at the end of Process step 3 [%]
H7RefVP4	IR-Emitter 7 Reference Voltage at the end of Process step 4 [%]
H7RefVP5	IR-Emitter 7 Reference Voltage at the end of Process step 5 [%]
H7RefVP6	IR-Emitter 7 Reference Voltage at the end of Process step 6 [%]
H7RefVP7	IR-Emitter 7 Reference Voltage at the end of Process step 7 [%]
H7RefVP8	IR-Emitter 7 Reference Voltage at the end of Process step 8 [%]
H8ActIP	IR-Emitter 8 Actual Current at the end of actual Process step [%]
H8ActIP1	IR-Emitter 8 Actual Current at the end of Process step 1 [%]
H8ActIP2	IR-Emitter 8 Actual Current at the end of Process step 2 [%]
H8ActIP3	IR-Emitter 8 Actual Current at the end of Process step 3 [%]
H8ActIP4	IR-Emitter 8 Actual Current at the end of Process step 4 [%]
H8ActIP5	IR-Emitter 8 Actual Current at the end of Process step 5 [%]
H8ActIP6	IR-Emitter 8 Actual Current at the end of Process step 6 [%]
H8ActIP7	IR-Emitter 8 Actual Current at the end of Process step 7 [%]
H8ActIP8	IR-Emitter 8 Actual Current at the end of Process step 8 [%]
H8ActVP	IR-Emitter 8 Actual Voltage at the end of actual Process step [%]
H8ActVP1	IR-Emitter 8 Actual Voltage at the end of Process step 1 [%]
H8ActVP2	IR-Emitter 8 Actual Voltage at the end of Process step 2 [%]
H8ActVP3	IR-Emitter 8 Actual Voltage at the end of Process step 3 [%]
H8ActVP4	IR-Emitter 8 Actual Voltage at the end of Process step 4 [%]
H8ActVP5	IR-Emitter 8 Actual Voltage at the end of Process step 5 [%]
H8ActVP6	IR-Emitter 8 Actual Voltage at the end of Process step 6 [%]

Table B.1 Data Records for GVX/GLX/GIX/GVH/GL

Tag	Notes
H8ActVP7	IR-Emitter 8 Actual Voltage at the end of Process step 7 [%]
H8ActVP8	IR-Emitter 8 Actual Voltage at the end of Process step 8 [%]
H8MTimeP	IR-Emitter 8 Motion Time at the end of actual Process step [s]
H8MTimeP1	IR-Emitter 8 Motion Time at the end of Process step 1 [s]
H8MTimeP2	IR-Emitter 8 Motion Time at the end of Process step 2 [s]
H8MTimeP3	IR-Emitter 8 Motion Time at the end of Process step 3 [s]
H8MTimeP4	IR-Emitter 8 Motion Time at the end of Process step 4 [s]
H8MTimeP5	IR-Emitter 8 Motion Time at the end of Process step 5 [s]
H8MTimeP6	IR-Emitter 8 Motion Time at the end of Process step 6 [s]
H8MTimeP7	IR-Emitter 8 Motion Time at the end of Process step 7 [s]
H8MTimeP8	IR-Emitter 8 Motion Time at the end of Process step 8 [s]
H8RefIP	IR-Emitter 8 Reference Current at the end of actual Process step [%]
H8RefIP1	IR-Emitter 8 Reference Current at the end of Process step 1 [%]
H8RefIP2	IR-Emitter 8 Reference Current at the end of Process step 2 [%]
H8RefIP3	IR-Emitter 8 Reference Current at the end of Process step 3 [%]
H8RefIP4	IR-Emitter 8 Reference Current at the end of Process step 4 [%]
H8RefIP5	IR-Emitter 8 Reference Current at the end of Process step 5 [%]
H8RefIP6	IR-Emitter 8 Reference Current at the end of Process step 6 [%]
H8RefIP7	IR-Emitter 8 Reference Current at the end of Process step 7 [%]
H8RefIP8	IR-Emitter 8 Reference Current at the end of Process step 8 [%]
H8RefVP	IR-Emitter 8 Reference Voltage at the end of actual Process step [%]
H8RefVP1	IR-Emitter 8 Reference Voltage at the end of Process step 1 [%]
H8RefVP2	IR-Emitter 8 Reference Voltage at the end of Process step 2 [%]
H8RefVP3	IR-Emitter 8 Reference Voltage at the end of Process step 3 [%]
H8RefVP4	IR-Emitter 8 Reference Voltage at the end of Process step 4 [%]
H8RefVP5	IR-Emitter 8 Reference Voltage at the end of Process step 5 [%]
H8RefVP6	IR-Emitter 8 Reference Voltage at the end of Process step 6 [%]
H8RefVP7	IR-Emitter 8 Reference Voltage at the end of Process step 7 [%]
H8RefVP8	IR-Emitter 8 Reference Voltage at the end of Process step 8 [%]
HeatCyclT	Last Heating Cycle Time [s]
HeatStep	Heating Step Number (Step number from heating sequence, executing right now.)
HeatStep1N	Heating Step 1 Name UNICODE
HeatStep1T	Heating Step 1 Time duration [s]
HeatStep2N	Heating Step 2 Name UNICODE
HeatStep2T	Heating Step 2 Time duration [s]
HeatStep3N	Heating Step 3 Name UNICODE

Table B.1 Data Records for GVX/GLX/GIX/GVH/GL

Tag	Notes
HeatStep3T	Heating Step 3 Time duration [s]
HeatStep4N	Heating Step 4 Name UNICODE
HeatStep4T	Heating Step 4 Time duration [s]
HeatStep5N	Heating Step 5 Name UNICODE
HeatStep5T	Heating Step 5 Time duration [s]
HeatStep6N	Heating Step 6 Name UNICODE
HeatStep6T	Heating Step 6 Time duration [s]
HeatStep7N	Heating Step 7 Name UNICODE
HeatStep7T	Heating Step 7 Time duration [s]
HeatStep8N	Heating Step 8 Name UNICODE
HeatStep8T	Heating Step 8 Time duration [s]
HeatTAvg	Average from last 9 Heating cycles [s]
JoinCyclT	Last Joining Cycle Time [s]
JoinStep	Joining Step Number (Step number from joining sequence, executing right now.)
JoinStep1N	Joining Step 1 Name UNICODE
JoinStep1T	Joining Step 1 Time duration [s]
JoinStep2N	Joining Step 2 Name UNICODE
JoinStep2T	Joining Step 2 Time duration [s]
JoinStep3N	Joining Step 3 Name UNICODE
JoinStep3T	Joining Step 3 Time duration [s]
JoinStep4N	Joining Step 4 Name UNICODE
JoinStep4T	Joining Step 4 Time duration [s]
JoinStep5N	Joining Step 5 Name UNICODE
JoinStep5T	Joining Step 5 Time duration [s]
JoinStep6N	Joining Step 6 Name UNICODE
JoinStep6T	Joining Step 6 Time duration [s]
JoinStep7N	Joining Step 7 Name UNICODE
JoinStep7T	Joining Step 7 Time duration [s]
JoinStep8N	Joining Step 8 Name UNICODE
JoinStep8T	Joining Step 8 Time duration [s]
JoinTAvg	Average from last 9 Joining cycles [s]
JoinTLas	Actual Joining Time for Laser [s]
JoinTLasP	Joining Time for Laser at the end of actual Process step [s]
JoinTLasP1	Joining Time for Laser at the end of Process step 1 [s]
JoinTLasP2	Joining Time for Laser at the end of Process step 2 [s]
JoinTLasP3	Joining Time for Laser at the end of Process step 3 [s]

Table B.1 Data Records for GVX/GLX/GIX/GVH/GL

Tag	Notes
JoinTLasP4	Joining Time for Laser at the end of Process step 4 [s]
JoinTLasP5	Joining Time for Laser at the end of Process step 5 [s]
JoinTLasP6	Joining Time for Laser at the end of Process step 6 [s]
JoinTLasP7	Joining Time for Laser at the end of Process step 7 [s]
JoinTLasP8	Joining Time for Laser at the end of Process step 8 [s]
JoinTVib	Actual Joining Time for Vibration [s]
JoinTVibP	Joining Time for Vibration at the end of actual Process step [s]
JoinTVibP1	Joining Time for Vibration at the end of Process step 1 [s]
JoinTVibP2	Joining Time for Vibration at the end of Process step 2 [s]
JoinTVibP3	Joining Time for Vibration at the end of Process step 3 [s]
JoinTVibP4	Joining Time for Vibration at the end of Process step 4 [s]
JoinTVibP5	Joining Time for Vibration at the end of Process step 5 [s]
JoinTVibP6	Joining Time for Vibration at the end of Process step 6 [s]
JoinTVibP7	Joining Time for Vibration at the end of Process step 7 [s]
JoinTVibP8	Joining Time for Vibration at the end of Process step 8 [s]
MachMode	Machine Mode (0 = No Mode, 1 = Set-up Mode, 2 = Automatic Mode, 3 = Automatic Step Mode, 4 = Tool Load Mode, 5 = Homing, 6 = Tool Unload Mode)
MachRun	Machine Runtime (machine operating hours) [h]
MachSafety	Machine safety circuits ok
MachType	Machine Type
PosActP	Actual Position at the end of actual Process step [mm]
PosActP1	Actual Position at the end of Process step 1 [mm]
PosActP2	Actual Position at the end of Process step 2 [mm]
PosActP3	Actual Position at the end of Process step 3 [mm]
PosActP4	Actual Position at the end of Process step 4 [mm]
PosActP5	Actual Position at the end of Process step 5 [mm]
PosActP6	Actual Position at the end of Process step 6 [mm]
PosActP7	Actual Position at the end of Process step 7 [mm]
PosActP8	Actual Position at the end of Process step 8 [mm]
PosRefP	Reference Position at the end of actual Process step [mm]
PosRefP1	Reference Position at the end of Process step 1 [mm]
PosRefP2	Reference Position at the end of Process step 2 [mm]
PosRefP3	Reference Position at the end of Process step 3 [mm]
PosRefP4	Reference Position at the end of Process step 4 [mm]
PosRefP5	Reference Position at the end of Process step 5 [mm]
PosRefP6	Reference Position at the end of Process step 6 [mm]

Table B.1 Data Records for GVX/GLX/GIX/GVH/GL

Tag	Notes
PosRefP7	Reference Position at the end of Process step 7 [mm]
PosRefP8	Reference Position at the end of Process step 8 [mm]
ProjNum	Project Number
Recipe	Actual Recipe/Dataset Name
StatusWord	Status Word
ToolCode	Tool Code
ToolSwitch	Tool Switch
UserName	Name of Currently Logged User
UserNameU	Name of Currently Logged User UNICODE
WeldAct	Actual Reached Welding Depth [mm]
WeldActP	Reached Welding Depth at the end of actual Process step [mm]
WeldActP1	Reached Welding Depth at the end of Process step 1 [mm]
WeldActP2	Reached Welding Depth at the end of Process step 2 [mm]
WeldActP3	Reached Welding Depth at the end of Process step 3 [mm]
WeldActP4	Reached Welding Depth at the end of Process step 4 [mm]
WeldActP5	Reached Welding Depth at the end of Process step 5 [mm]
WeldActP6	Reached Welding Depth at the end of Process step 6 [mm]
WeldActP7	Reached Welding Depth at the end of Process step 7 [mm]
WeldActP8	Reached Welding Depth at the end of Process step 8 [mm]
WeldRef	Actual Required Welding Depth [mm]
WeldRefP	Required Welding Depth at the end of actual Process step [mm]
WeldRefP1	Required Welding Depth at the end of Process step 1 [mm]
WeldRefP2	Required Welding Depth at the end of Process step 2 [mm]
WeldRefP3	Required Welding Depth at the end of Process step 3 [mm]
WeldRefP4	Required Welding Depth at the end of Process step 4 [mm]
WeldRefP5	Required Welding Depth at the end of Process step 5 [mm]
WeldRefP6	Required Welding Depth at the end of Process step 6 [mm]
WeldRefP7	Required Welding Depth at the end of Process step 7 [mm]
WeldRefP8	Required Welding Depth at the end of Process step 8 [mm]

B.2 2000Xc/2000X Series

Table B.2 Data Records for 2000Xc/2000X Series

	Variable Index	Tag	Notes
Record 1 (System Configuration)	1	UserId	
	2	ActAssyN	
	3	PSAssyN	
	4	StackAssyN	
	5	ActSerialN	
	6	PSSerialN	
	7	PS Watts	
	8	PS Freq	
	9	PS Machine	2000Xc
Record 2 (Primary Weld Results)	1	CycleCount	
	2	Date&Time	2020.03.19 14:11:22
	3	WeldTime	msec
	4	TotalEnergy	0.1 joules
	5	WeldAbs	0.0001 in
	6	TotalAbs	0.0001 in
	7	WeldColl	0.0001 in
	8	TotalColl	0.0001 in
	9	FreqStart	Hz
	10	FreqChange	Hz
	11	FreqMin	Hz
	12	FreqMax	Hz
	13	DownSpeed	0.01 in/sec
	14	Weldmode	1= time
	15	PeakPower	0.10%
	16	WeldPress	0.1 PSI
	17	WeldFEnd	0.1lbs
	18	HoldFEnd	0.1lbs
	19	TrigForce	0.1lbs
	20	TotalCycleTime	msec

Table B.2 Data Records for 2000Xc/2000X Series

	Variable Index	Tag	Notes
Record 3 (Secondary Weld Results)	1	CycleCount	
	2	UserId	
	3	RecipeNum	
	4	RecipeRev	
	5	RecipeVal	
	6	ActAssyN	
	7	PSAssyN	
	8	StackAssyN	
	9	ActSerialN	
	10	PSSerialN	
	11	UDIScan	
	12	RejectBitR	
	13	SuspectBitR	
	14	NoCycAlarm	
	15	OverLAlarm	
	16	EFailAlarm	
	17	CyclMAlarm	
	18	CalibAlarm	
	19	Warnings	
	20	RecipeName	
Record 4 (Tertiary Weld Results)	1	CycleCount	
	2	AmplitudeA	
	3	AmplitudeB	

B.3 L20 Touchscreen & L20 VersaGraphix

Table B.3 Data Records for L20 Touchscreen & L20 VersaGraphix

	Variable Index	Tag	Notes
Record 1 (Power On Info & Weld Data)	1	MachType	Actuator Type
	2	PSFreq	PS Type (Frequency)
	3	PSWattage	General Power
	4	DAT.Alarm	Alarm Info
	5	DAT.PstNum	Preset Number
	6	DAT.PstCnt	Preset Counter
	7	DAT.Amp	Weld Amplitude
	8	DAT.Width	Weld Width
	9	DAT.TP	Trigger Pressure
	10	DAT.WP	Weld Pressure
	11	DAT.WdTime	Weld Time
	12	DAT.PkPwr	Peak Power
	13	DAT.PreH	Pre-Height
	14	DAT.PosH	Post-Height
Record 2 (Preset Setting)	1	PST.Mode	Weld Mode
	2	PST.Name	Preset Name
	3	PST.Energy	Energy Setting
	4	PST.Width	Width Setting
	5	PST.TP	Trigger Pressure Setting
	6	PST.WP	Weld Pressure Setting
	7	PST.AMP	Amplitude Setting
	8	PST.Time+	Time High
	9	PST.Time-	Time Low
	10	PST.Pwr+	Power High
	11	PST.Pwr-	Power Low
	12	PST.PreH+	Pre-Height High
	13	PST.PreH-	Pre-Height Low
	14	PST.H+	Post-Height High
	15	PST.H-	Post-Height Low
16	PST.HoldT	Hold Time Setting	
17	PST.Abdel	Afterburst Delay	
18	PST.Abdur	Afterburst Duration	
19	PST.PreBst	Preburst Setting	

[This page intentionally left blank]

Appendix C: UaExpert Client

C.1 UaExpert Client Example58

C.1 UaExpert Client Example

This example shows data access by free client software UaExpert. UaExpert can be downloaded from <https://www.unified-automation.com> (Downloads > OPC UA Clients).

Follow this procedure to access data from Branson product connected to DIG with OPC-UA server.

Prerequisites:

- Branson product/machine with DIG connection supported by product/machine controller
- Data interface gateway (DIG)
- Network connection as described in chapter Network Configuration
- Branson product/machine settings as described in chapter Machine settings
- PC connected to the same network as DIG plug 1
- UaExpert (OPC-UA client) installed in PC

Table C.1 UaExpert Client

Step	Description
1	Start the UaExpert software in PC.
2	Click on Server > Add. The <i>Add Server</i> dialog opens.
3	Add a name to the Configuration Name field.
4	Navigate to Advanced tab and enter data interface gateway's specific URL address, as described in section 2.7 Data Interface Gateway (DIG) .
5	Optionally you can check Connect Automatically to save your settings.
	<p>Figure C.1 UaExpert Add S0server Dialog</p> 
6	Confirm and click Server > Connect.
7	Browse the data structure of Branson machines/products connected to your DIG on the left-hand side of the screen. Refer to Appendix B: Data Records for more information.

Table C.1 UaExpert Client

Step	Description
------	-------------

For the example below, we have configured Machine 1 to be a 2000Xc; refer to section [2.3 2000Xc Ultrasonic Welder](#) above and enable the DI Gateway, and Records 1-3 on the system configuration page.

Figure C.2 UaExpert Data Structure From DIG

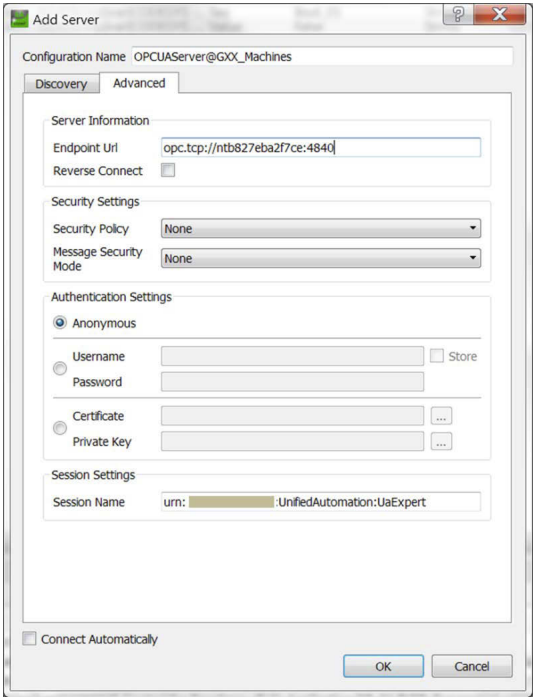
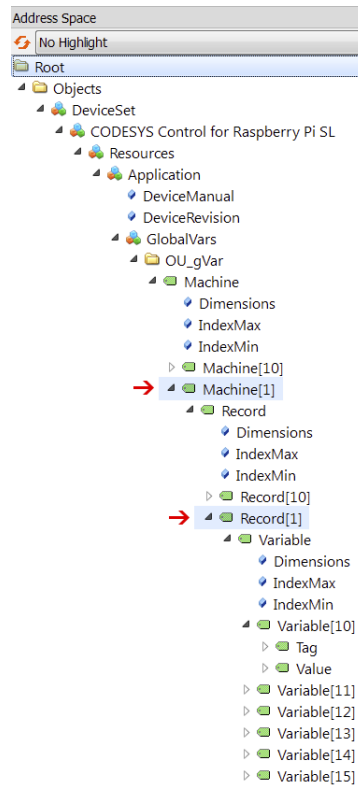

8

Select Data Record 1 from Machine 1 which you want to indicate, and drag-and-drop them into the main window. Now you can see online values as shown in [Appendix B: Data Records](#). Double click on the Value Column to see the entire record of values.

Figure C.3 UaExpert Record 1 2000Xc

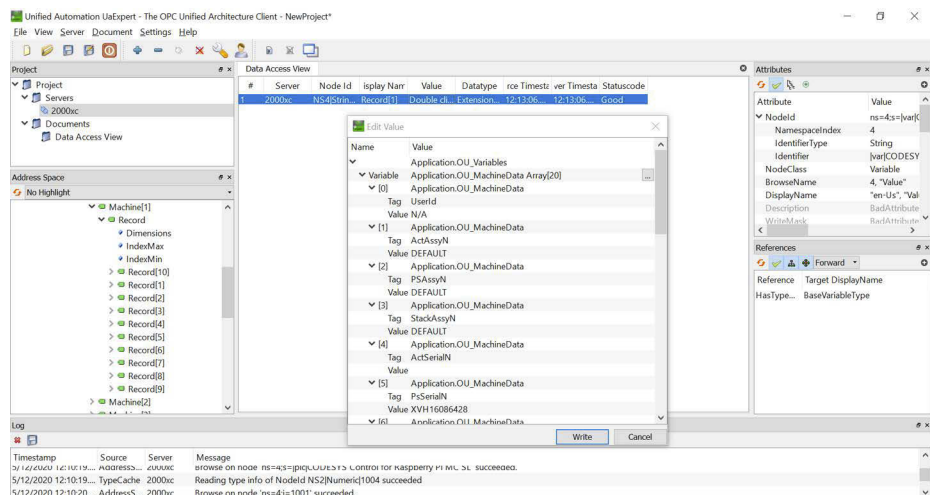

9

[This page intentionally left blank]

Appendix D: RS232 to Ethernet Converter

D.1 RS232 to Ethernet Configuration.62

D.1 RS232 to Ethernet Configuration

The module RS232 to Ethernet is configured to Machine 01.

Table D.1 RS232 to Ethernet Configuration

Step	Description
1	Connect the converter to your PC via Ethernet cable.
2	Connect the RS232 Null Modem Cable between the machine and the converter.
3	Configure your PC IPv4 address with the same network segment of your converter. <ul style="list-style-type: none"> TCP232 converter default IP: 150.150.0.2 Subnet: 255.255.255.0
4	Login into TCP232 converter configuration server. <ul style="list-style-type: none"> Default username/password: admin/admin

Change the local IP configuration.
To change Machine numbers, IP address and Port number must be changed.

NOTICE
Screenshots elow are from the RS232 setup web-pages.

5

Machine	Port	IP Address
Machine 01	65100	150.150.150.10
Machine 02	65101	150.150.150.11
...
Machine 10	65109	150.150.150.19

Appendix E: Warranty

For warranty information please reference the warranty section of Terms and Conditions found at: www.emerson.com/branson-terms-conditions

[This page intentionally left blank]

[This page intentionally left blank]



Branson Ultrasonics Corporation
120 Park Ridge Road
Brookfield, CT 06804
(203) 796-0400
<http://www.bransonultrasonics.com>

Copyright © 2022 Branson Ultrasonics Corporation. All rights reserved. Contents of this publication may not be reproduced in any form without the written permission of Branson Ultrasonics Corporation.